

Automation

Low Voltage Switch & Controlgear

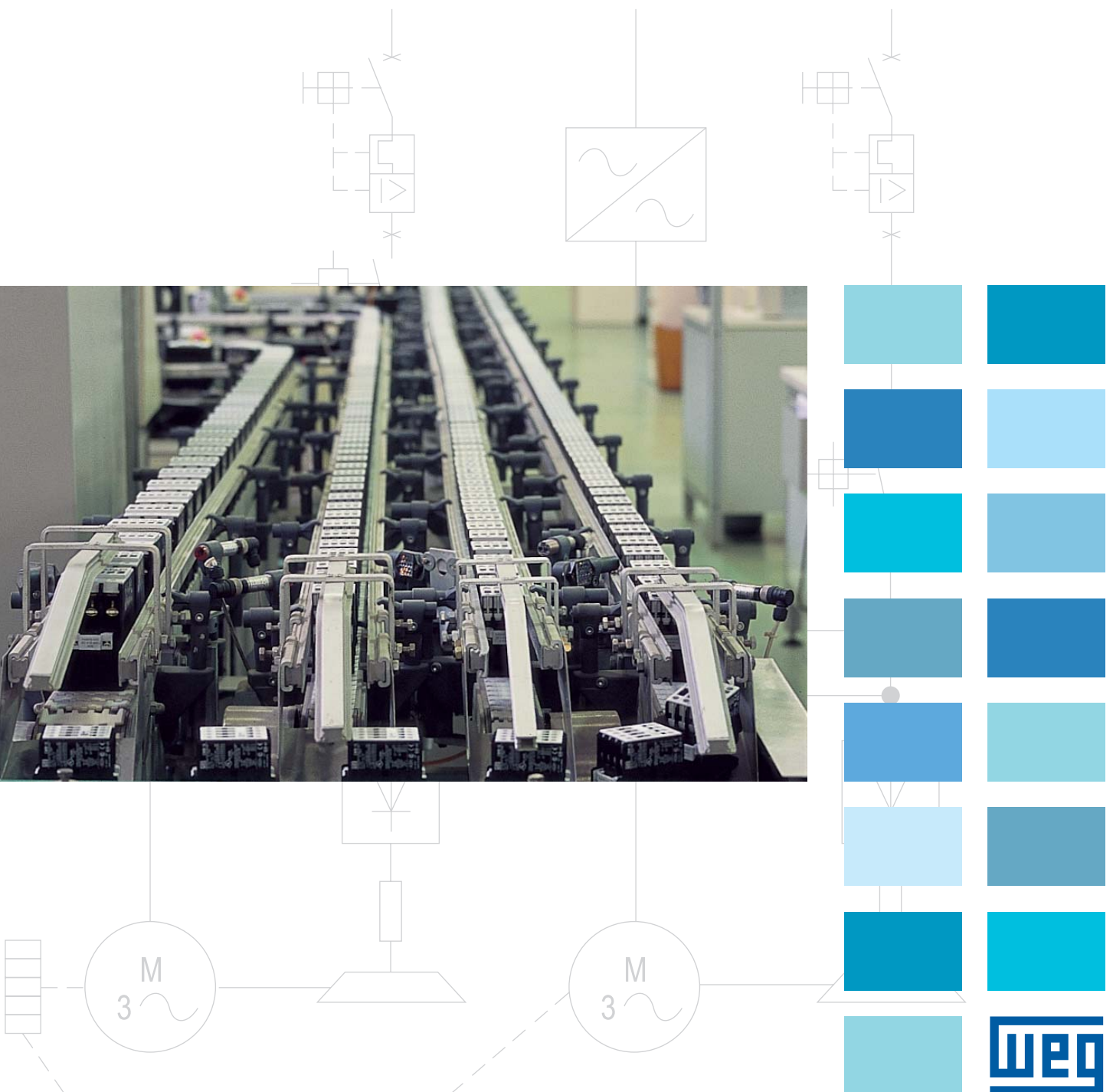

High Technology in Manufactory



Research and Development



Product Certifications



WEG Automation - Low Voltage Switch & Controlgear



	Page
Contactors and Overload Relays	05



Motor Protective Circuit Breakers	63
--	----



Enclosed and Open Starters	101
---	-----



Pushbuttons and Pilot Lights	109
---	-----



Electronic Relays	123
--------------------------------	-----



Terminal Blocks	145
------------------------------	-----







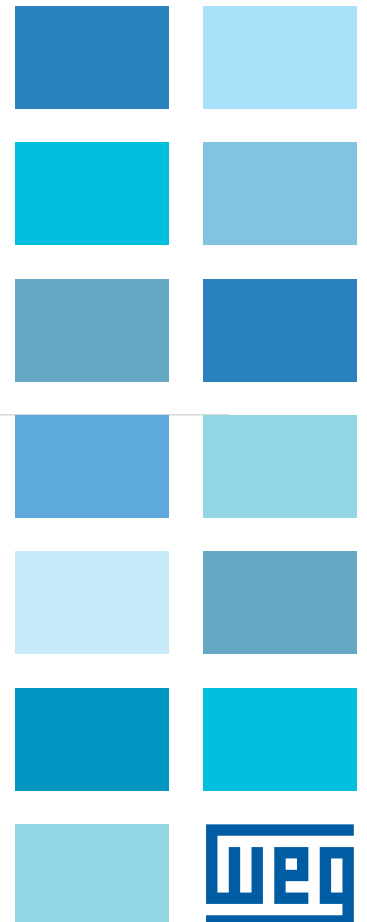
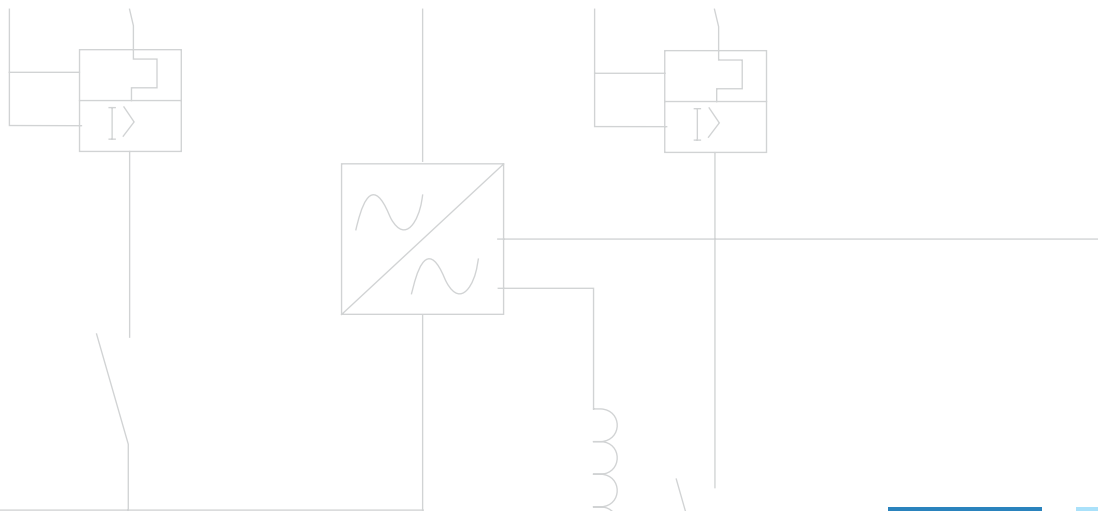

Contactors and Overload Relays

Operation and Protection of Motors

















Overview







Reference	3 poles	CWC07	CWC09	CWC012	CWC016	CWC025	
Rated operational power ¹⁾							
220 / 230VAC	kW / hp	1.5 / 2	2.2 / 3	3 / 4	4 / 5	5.5 / 7.5	
380VAC	kW / hp	3 / 4	4 / 5	5.5 / 7.5	7.5 / 10	11 / 15	
400 / 415VAC	kW / hp	3 / 4	4 / 5	5.5 / 7.5	7.5 / 10	11 / 15	
440VAC	kW / hp	3.7 / 5	4.5 / 6	5.5 / 7.5	7.5 / 10	11 / 15	
500VAC	kW / hp	3.7 / 5	4.5 / 6	5.5 / 7.5	7.5 / 10	11 / 15	
690VAC	kW / hp	3.7 / 5	5.5 / 7.5	7.5 / 10	7.5 / 10	11 / 15	
Rated operational current I_e AC-3 ($U_e \leq 440V$) A		7	9	12	16	25	
Conventional thermal current $I_{th} = I_e$ AC-1 A		18	20	22	22	32	
Rated operational current I_e AC-4 ($U_e \leq 440V$) A		2.8	3.5	4.5	5	9	
Overload relay A		RW17-1D 	0.28...0.4 0.4...0.63 0.56...0.8 0.8...1.2 1.2...1.8 1.8...2.8	2.8...4 4...6.3 5.6...8 7...10 8...12.5 10...15 11...17	RW17-2D 	7...10 8...12.5 10...15 11...17 15...23 22...32	
Auxiliary contact blocks			BFC0-20 (2NO) BFC0-22 (2NO + 2NC) BFC0-11 (1NO + 1NC) BFC0-04 (4NC) BFC0-02 (2NC) BFC0-31 (2NO + 1NC) BFC0-40 (4NO) BFC0-13 (1NO + 3NC)				BFC025-11 (1NO+1NC) BFC025-20 (2NO) BFC025-02 (2NC)
Mechanical interlock		 BICO					
Timer				ON-Delay (TECO) OFF-Delay (TDCO) Star-Delta (TETCO)			
Surge suppressor				RC block: RCCO-1 D49 12-24V 50/60Hz RCCO-2 D53 24-48V 50/60Hz RCCO-3 D55 50-127V 50/60Hz RCCO-4 D63 130-250V 50/60Hz RCCO-5 D84 275-380V 50/60Hz RCCO-6 D73 400-510V 50/60Hz Varistor block: VRCO-1 E01 12-48V 50/60Hz / 12-60VDC VRCO-2 E34 50-127V 50/60Hz / 60-180VDC VRCO-3 E50 130-250V 50/60Hz / 180-300VDC VRCO-4 E41 277-380V 50/60Hz / 300-510VDC VRCO-5 D73 400-510V 50/60Hz Diode block(CWC07-16): DIC0-1 C33 12-600VDC			







Notes: 1) Some motors characteristics may vary according to each manufacturer.

										
CWM9	CWM12	CWM18	CWM25	CWM32	CWM40	CWM50	CWM65	CWM80	CWM95	CWM105
2.2 / 3	3 / 4	4.5 / 6	5.5 / 7.5	9.2 / 12.5	11 / 15	15 / 20	18.5 / 25	22 / 30	22 / 30	30 / 40
4 / 5	5.5 / 7.5	7.5 / 10	11 / 15	15 / 20	18.5 / 25	22 / 30	30 / 40	37 / 50	45 / 60	55 / 75
4 / 5	5.5 / 7.5	7.5 / 10	11 / 15	15 / 20	18.5 / 25	22 / 30	30 / 40	45 / 60	55 / 75	55 / 75
4.5 / 6	5.5 / 7.5	9.2 / 12.5	11 / 15	15 / 20	22 / 30	30 / 40	37 / 50	45 / 60	55 / 75	55 / 75
4.5 / 6	5.5 / 7.5	9.2 / 12.5	11 / 15	15 / 20	22 / 30	30 / 40	37 / 50	45 / 60	55 / 75	55 / 75
5.5 / 7.5	7.5 / 10	11 / 15	11 / 15	18.5 / 25	22 / 30	30 / 40	37 / 50	45 / 60	55 / 75	55 / 75
9	12	18	25	32	40	50	65	80	95	105
25	25	32	45	60	60	90	110	110	140	140
5	7	8	12	16	18.5	23	30	37	44	50
RW27-1D 	0.28...0.4 0.4...0.63 0.56...0.8 0.8...1.2 1.2...1.8 1.8...2.8 2.8...4 4...6.3	5.6...8 7...10 8...12.5 10...15 11...17 15...23 22...32	RW67-1D 	25...40 32...50	RW67-2D 	40...57 50...63 57...70 63...80	RW117-1D 	63...80 75...97 90...112		
	BCXMF10 (1NO) BCXMF01 (1NC) BCXMF A10 (1NC) BCXMF R01 (1NC)			BCXML 11 (1NO+1NC) BCXML 20 (2NO) BCXMRL 11 (1NO+1NC) BCXMRL 20 (2NO)						
 BLIM9-105										
-										
	RC block: BAMRC4 D53 24-48 V 50/60Hz BAMRC5 D55 50-127 V 50/60Hz BAMRC6 D63 130-250 V 50/60Hz Diode block: BAMDI10 C33 12-600 VDC Varistor block: BAMV1 D68 270-380 V 50/60Hz BAMV2 D73 400-510 V 50/60Hz					RC block: BAMRC7 D53 24-48 V 50/60Hz BAMRC8 D55 50-127 V 50/60Hz BAMRC9 D63 130-250 V 50/60Hz Varistor block: BAMV1 D68 270-380 V 50/60Hz BAMV2 D73 400-510 V 50/60Hz				

Overview

Reference	3 Poles	CWM112 ¹⁾	CWM150 ³⁾	CWM180 ¹⁾	CWM250 ¹⁾	CWM300 ³⁾
Rated operational power ⁴⁾						
220 / 230VAC	kW / hp	30 / 40	45 / 60	55 / 75	75 / 100	90 / 125
380VAC	kW / hp	55 / 75	75 / 100	90 / 125	132 / 175	150 / 200
400 / 415VAC	kW / hp	55 / 75	75 / 100	90 / 125	132 / 175	160 / 220
440VAC	kW / hp	55 / 75	90 / 125	110 / 150	150 / 200	185 / 250
500VAC	kW / hp	55 / 75	90 / 125	110 / 150	160 / 220	200 / 270
690VAC	kW / hp	75 / 100	110 / 150	110 / 150	160 / 220	200 / 270
Rated operational current I _e AC-3 (U _e ≤ 440V)	A	112	150	180	250	300
Conventional thermal current I _m = I _e AC-1	A	180	225	225	350	410
Rated operational current I _e AC-4 (U _e ≤ 440V)	A	63	69	73	110	145
Overload relays	A	RW117-2D  75...97 90...112		RW317-1D  100...150 140...215 200...310 275...420		
		Auxiliary contact blocks  BCXML11 (1NO+1NC) BCXML20 (2NO) BCXML11 (1NO+1NC) BCXML20 (2NO)				
Mechanical interlock		 BLIM112-300				
Surge suppressor ²⁾		RC block: BAMRC13 D53 24-48V 50/60Hz BAMRC14 D56 50-250V 50/60Hz Varistor block: BAMV3 D68 270-380V 50/60Hz BAMV4 D73 400-510V 50/60Hz	-	RC block: BAMRC13 D53 24-48V 50/60Hz BAMRC14 D56 50-250V 50/60Hz Varistor block: BAMV3 D68 270-380V 50/60Hz BAMV4 D73 400-510V 50/60Hz	-	

Notes: 1) Available with AC coil or with electronic module - AC/DC
2) Only applicable for contactors without electronic module

			
CWME400³⁾		CWME630³⁾	CWME800³⁾
125 / 150		190 / 250	220 / 300
220 / 300		330 / 450	440 / 600
220 / 300		330 / 450	440 / 600
220 / 300		330 / 450	440 / 600
220 / 300		330 / 450	500 / 700
250 / 330		330 / 450	500 / 700
400		630	800
450		660	900
300		400	630
RW407-1D			
 400...600 560...840			
 BCXML11 CWME800 (1NO+1NC) BCXMR11 CWME800 (1NO+1NC)			
 BLIM CWME400		 BLIM CWME800	
-			

3) Only with electronic module.

Mini contactors

The CWC0 mini contactors have compact design and are OFFered as complete solution for switching and controlling motors.

Main Features

- AC-3 operation up to 25A.
- AC and DC mini contactors with the same frame size of series up to 16A.
- Rated insulation voltage 690V.
- Significantly less consumption and heat dissipation, allowing PLC direct operation without coupling relay.
- Wide range of accessories, compact and fast mounting.



Certifications



Mini contactors

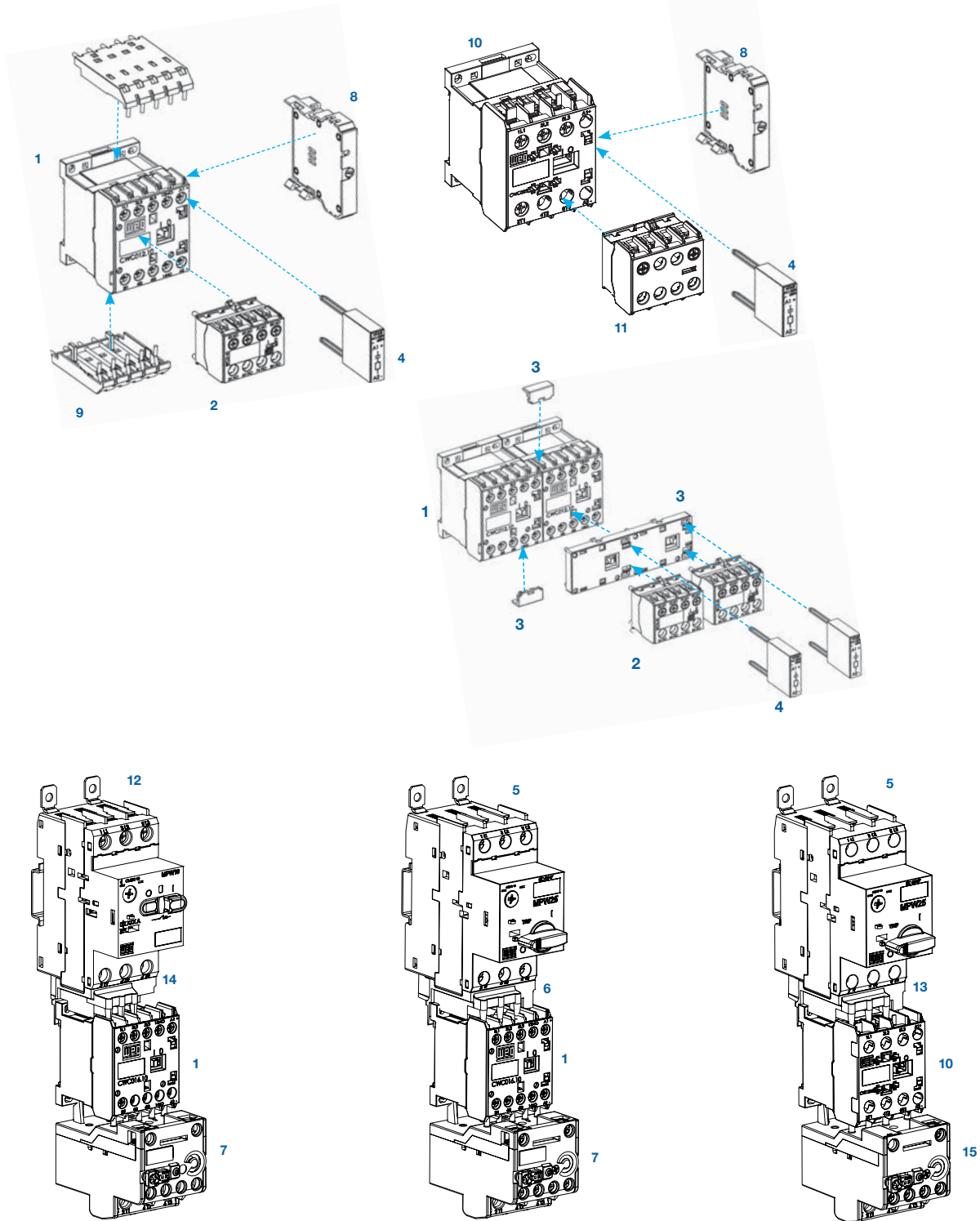

- 1 - Mini contactors CWC07...16
- 2 - Auxiliary frontal contact block BFC0
- 3 - Mechanical interlock block BICO
- 4 - Surge supsressor blocks RCC0 (RC), VRC0 (Varistor), DIC0 (Diode)
- 5 - Motor protective circuit breaker MPW25
- 6 - Connector ECCMP-C0 (MPW25 + CWC07...16)
- 7 - Overload Relay RW17-1D
- 8 - Electronic timers TEC0, TDC0 and TETCO
- 9 - Block module for printed circuit board CICO
- 10 - Mini contactor CWC025
- 11 - Auxiliary frontal contact block BFC025
- 12 - Motor protective circuit breaker MPW16
- 13 - Connector ECCMP-C025 (MPW25 + CWC025)
- 14 - Connector ECCMP-C016 (MPW16 + CWC07...16)
- 15 - Overload Relay RW17-2D

Mini contactors



Three-pole CWC0 mini contactors - 7A to 25A (AC-3)

Rated operational current I_e AC-3 ($U_e \leq 440V$) A	Conv. thermal current $I_n = I_e$ AC-1 A	Maximum rated operational power of three-phase motors 50/60 Hz ¹⁾						Auxiliary contacts per contactor		Reference code	AC coil	DC coil
		220V 230V kW / hp	380V kW / hp	400V 415V kW / hp	440V kW / hp	500V kW / hp	660V 690V kW / hp	$\begin{matrix} \cdot 3 \\ \\ \cdot 4 \end{matrix}$ NO	$\begin{matrix} \cdot 1 \\ \\ \cdot 2 \end{matrix}$ NC		Weight kg	
7	18	1.5 / 2	3 / 4	3 / 4	3.7 / 5	3.7 / 5	3.7 / 5	1 0	0 1	CWC07-10-30 ♦ CWC07-01-30 ♦	0.195	0.230
9	20	2.2 / 3	4 / 5	4 / 5	4.5 / 6	4.5 / 6	5.5 / 7.5	1 0	0 1	CWC09-10-30 ♦ CWC09-01-30 ♦		
12	22	3 / 4	5.5 / 7.5	5.5 / 7.5	5.5 / 7.5	5.5 / 7.5	7.5 / 10	1 0	0 1	CWC12-10-30 ♦ CWC12-01-30 ♦		
16	22	4 / 5	7.5 / 10	7.5 / 10	7.5 / 10	7.5 / 10	7.5 / 10	1 0	0 1	CWC16-10-30 ♦ CWC16-01-30 ♦		
25	32	5.5 / 7.5	11 / 15	11 / 15	11 / 15	11 / 15	11 / 15	0	0	CWC25-00-30 ♦	0.200	-

To complete the reference code, replace “♦” with the appropriate coil voltage code ²⁾ :

AC coil – 50/60Hz							
Applicable for CWC07...CWC25 models							
Coil voltage codes	D02	D07	D13	D24	D25	D34	D35
VAC – 50/60Hz	24	48	110	230	240	400	415

DC coil – Standard consumption coil					
Applicable for CWC07...CWC16 models					
Coil voltage codes	C03	C06	C07	C12	C15
VDC	24	42	48	110	220

DC coil – Low consumption coil ³⁾					
Applicable for CWC07...CWC16 models					
Coil voltage codes	L03	L06	L07	L12	L15
VDC	24	42	48	110	220

Notes: 1) Some motors characteristics may vary according to each manufacturer.

2) Other voltages available.



3) The mini CWC0 contactors with coils of low consumption only allow assembly of maximum 2 auxiliary contacts.

4) For selection of accessories, check page 17.

Mini contactors



Mini contactors for reversing starter with mechanical interlock CWCI0 - 7A to 16A (AC-3)

Rated operational current I_e AC-3 ($U_e \leq 440V$) A	Conv. thermal current $I_{th} = I_e$ AC-1 A	Maximum rated operational power of three-phase motors 50/60 Hz ¹⁾						Auxiliary contacts per contactor		Reference code	AC coil	DC coil
		220V 230V	380V	400V 415V	440V	500V	660V 690V				Weight kg	
7	18	1.5 / 2	3 / 4	3 / 4	3.7 / 5	3.7 / 5	3.7 / 5	1 0	0 1	CWCI07-10-30 ♦ CWCI07-01-30 ♦	0.395	0.480
9	20	2.2 / 3	4 / 5	4 / 5	4.5 / 6	4.5 / 6	5.5 / 7.5	1 0	0 1	CWCI09-10-30 ♦ CWCI09-01-30 ♦		
12	22	3 / 4	5.5 / 7.5	5.5 / 7.5	5.5 / 7.5	5.5 / 7.5	7.5 / 10	1 0	0 1	CWCI12-10-30 ♦ CWCI12-01-30 ♦		
16	22	4 / 5	7.5 / 10	7.5 / 10	7.5 / 10	7.5 / 10	7.5 / 10	1 0	0 1	CWCI16-10-30 ♦ CWCI16-01-30 ♦		

To complete the reference code, replace “♦” with the appropriate coil voltage code ²⁾ :

AC coil – 50/60Hz							
Applicable for CWCI07...CWCI016 models							
Coil voltage codes	D02	D07	D13	D24	D25	D34	D35
VAC – 50/60Hz	24	48	110	230	240	400	415

DC coil – Standard consumption coil					
Applicable for CWCI07...CWCI016 models					
Coil voltage codes	C03	C06	C07	C12	C15
VDC	24	42	48	110	220

DC coil – Low consumption coil ³⁾					
Applicable for CWCI07...CWCI016 models					
Coil voltage codes	L03	L06	L07	L12	L15
VDC	24	42	48	110	220

Notes: 1) Some motors characteristics may vary according to each manufacturer.

2) Other voltages available

3) The mini CWCI contactors with coils of low consumption only allow assembly of maximum 2 auxiliary contacts.

4) For selection of accessories, check page 17.

Mini contactors



Three-pole mini contactor for printed circuit boards CWC0 - 7A to 16A (AC-3)

Rated operational current I_e AC-3 ($U_e \leq 440V$) A	Conv. thermal current $I_{th} = I_e$ AC-1 A	Maximum rated operational power of three-phase motors 50/60 Hz ¹⁾						Auxiliary contacts per contactor		Reference code	AC coil	DC coil
		220V 230V kW / hp	380V kW / hp	400V 415V kW / hp	440V kW / hp	500V kW / hp	690V kW / hp	$\begin{matrix} \cdot 3 \\ \cdot 4 \\ NO \end{matrix}$	$\begin{matrix} \cdot 1 \\ \cdot 2 \\ NC \end{matrix}$		Weight kg	
7	18	1.5 / 2	3 / 4	3 / 4	3.7 / 5	3.7 / 5	3.7 / 5	1 0	0 1	CWC07-10-30♦ CWC07-01-30♦	0.395	0.480
9	20	2.2 / 3	4 / 5	4 / 5	4.5 / 6	4.5 / 6	5.5 / 7.5	1 0	0 1	CWC09-10-30♦ CWC09-01-30♦		
12	22	3 / 4	5.5 / 7.5	5.5 / 7.5	5.5 / 7.5	5.5 / 7.5	7.5 / 10	1 0	0 1	CWC12-10-30♦ CWC12-01-30♦		
16	22	4 / 5	7.5 / 10	7.5 / 10	7.5 / 10	7.5 / 10	7.5 / 10	1 0	0 1	CWC16-10-30♦ CWC16-01-30♦		

To complete the reference code, replace “♦” with the appropriate coil voltage code ²⁾ :

AC coil – 50/60Hz								
Applicable for CWC07...CWC016 models								
Coil voltage codes	D02	D07	D13	D24	D25	D34	D35	
VAC – 50/60Hz	24	48	110	230	240	400	415	

DC coil – Standard consumption coil					
Applicable for CWC07...CWC016 models					
Coil voltage codes	C03	C06	C07	C12	C15
VDC	24	42	48	110	220

DC coil – Low consumption coil ³⁾					
Applicable for CWC07...CWC016 models					
Coil voltage codes	L03	L06	L07	L12	L15
VDC	24	42	48	110	220

Notes: 1) Some motors characteristics may vary according to each manufacturer.

2) Other voltages available

3) The mini CWC0 contactors with coils of low consumption only allow assembly of maximum 2 auxiliary contacts.

4) For selection of accessories, check page 17.

Mini contactors

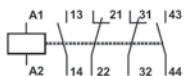
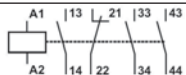
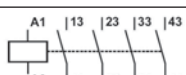
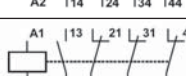
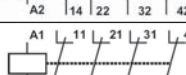

Control relay CWCA0

Rated thermal current I_{th} AC-1 A	Rated current I_b AC-15 A					Circuit diagram	Reference code	AC coil	DC coil
	220V 230V	380V 400V	415V 440V	500V	660V 690V			Weight kg	
10	10	6	5	4	2	 22 E	CWCA0-22-00 ♦	0,180	0,200
						 31 E	CWCA0-31-00 ♦		
						 40 E	CWCA0-40-00 ♦		
						 13 E	CWCA0-13-00 ♦		
						 04 E	CWCA0-04-00 ♦		

To complete the reference code, replace “♦” with the appropriate coil voltage code ²⁾ :

AC Coil - 50/60Hz								
Applicable for CWCA0 models								
Coil voltage codes	D02	D07	D13	D24	D25	D34	D35	
VAC - 50/60Hz	24	48	110	230	240	400	415	

DC Coil - Standard Consumption					
Applicable for CWCA0 models					
Coil voltage codes	C03	C07	C09	C12	C15
VDC	24	48	60	110	220

DC Coil - Low Consumption ³⁾					
Applicable for CWCA0 models					
Coil voltage codes	L03	L06	L07	L12	L15
VDC	24	42	48	110	220

Notes: 1) Some motors characteristics may vary according to each manufacturer.

2) Other voltages available

3) The mini CWCO contactors with coils of low consumption only allow assembly of maximum 2 auxiliary contacts.

4) For selection of accessories, check page 17.

Mini contactors



Four-pole(4P and 2P/2R) mini contactors CWC0 up to 22A (AC-1)

Conventional thermal current $I_e=I_{th}$ AC-1 A	Main contacts		Reference code	AC coil	DC coil
	NO	NC		Weight kg	
18	4	0	CWC07-00-40 ♦	0.195	0.230
20			CWC09-00-40 ♦		
22			CWC012-00-40 ♦		
22			CWC016-00-40 ♦		
18	2	2	CWC07-00-22 ♦		
20			CWC09-00-22 ♦		
22			CWC012-00-22 ♦		
22			CWC016-00-22 ♦		

To complete the reference code, replace “♦” with the appropriate coil voltage code ²⁾ :

AC Coil - 50/60Hz							
Applicable for All models							
Coil voltage codes	D02	D07	D13	D24	D25	D34	D35
VAC - 50/60Hz	24	48	110	230	240	400	415

DC Coil - Standard Consumption					
Applicable for CWC07...CWC016 Four-pole(4NO) models					
Coil voltage codes	C03	C07	C09	C12	C15
VDC	24	48	60	110	220

DC Coil - Low Consumption ³⁾					
Applicable for CWC07...CWC016 Four-pole(4NO) models					
Coil voltage codes	L03	L06	L07	L12	L15
VDC	24	42	48	110	220

DC Coil (0.75 x U _c)					
Applicable for CWC07...CWC016 Four-pole 2P/2R(2NO+2NC) models					
Coil voltage codes	R03	R06	R07	R12	R15
VDC	24	42	48	110	220

Notes: 1) Some motors characteristics may vary according to each manufacturer.























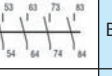

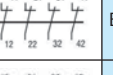

2) Other voltages available

3) The mini CWC0 contactors with coils of low consumption only allow assembly of maximum 2 auxiliary contacts.

4) For selection of accessories, check page 17.

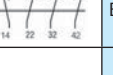
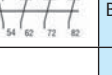
Mini contactors - Accessories

Auxiliary contact blocks for CWC07 to CWC025 and CWCA0

Illustrative picture	For use with	Max. number of contacts/mini contactor	Auxiliary contacts		For use with CWC0 (3 pole)		For use with CWC0 (4 pole)		For use with CWCA0		Weight kg		
			NO	NC	Terminal markings	Reference Code	Terminal markings	Reference Code	Terminal markings	Reference Code			
	CWC07...16 CWCA0	2	2	0		BFC0-20		BFC4-20		BFCA-20	0,03		
			1	1		BFC0-11		BFC4-11		BFCA-11			
			0	2		BFC0-02		BFC4-02		BFCA-02			
		4	4	0		BFC0-40*		BFC4-40*		BFCA-40*			
			2	2		BFC0-22*		BFC4-22*		BFCA-22*			
			0	4		BFC0-04*		BFC4-04*		BFCA-04*			
			3	1		BFC0-31*		BFC4-31*		BFCA-31*			
			1	3		BFC0-13*		BFC4-13*		BFCA-13*			
			CWC025	2	2	0		BFC025-20	-	-		-	-
					1	1		BFC025-11	-	-		-	-
0	2					BFC025-02	-	-	-	-			

* The CWC0 mini contactors with DC coils of low consumption does not accept 4 auxiliary contacts. For applications that use 4 auxiliary contacts use CWC0 with DC coils of standard consumption.

Mechanical interlock for mini contactors CWC07 to CWC016 and CWCA0

Illustrative picture	Description	Reference Code	Weight kg
	<ul style="list-style-type: none"> - Front mounting; - For the mechanical interlock using 2 minicontactors (AC or DC coil); - Allows to be mounted with the following accessories: auxiliary contact block, surge suppressor and timers. 	BICO	0,014

Mini contactors - Accessories

Surge suppressors for mini contactors CWC07 to CWC025

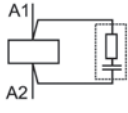
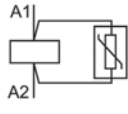
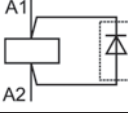

- Fast front mounting (clip on).
- It allows to be mounted with all the accessories.

Illustrative picture	For use with	Circuit diagram	Voltage	Reference Code	Weight kg	
	CWC07...25		12-24V 50/60Hz	RCC0-1 D49	0.008	
			24-48V 50/60Hz	RCC0-2 D53		
			50-127V 50/60Hz	RCC0-3 D55		
			130-250V 50/60Hz	RCC0-4 D63		
			275-380V 50/60Hz	RCC0-5 D84		
	CWC07...16		12-48V 50/60Hz / 12-60VDC	VRC0-1 E49		
			50-127V 50/60Hz / 60-180VDC	VRC0-2 E34		
			130-250V 50/60Hz / 180-300VDC	VRC0-3 E50		
			277-380V 50/60Hz / 300-510VDC	VRC0-4 E41		
			400-510V 50/60Hz	VRC0-5 D73		
				12-600VDC		DIC0-1 C33

Electronic timing relay for mini contactors CWC07 to CWC016

- Right-side fast mounting
- Up to 30 minutes timing
- LED status indication

Illustrative picture	Function	Time	Voltages	Reference Code	Weight kg	
	On-Delay (TECO)	3 - 0,3 to 3 seconds	24-240V 50/60Hz - DC	TECO-U003S-E05	0.02	
		10 - 1 to 10 seconds		TECO-U010S-E05		
		30 - 3 to 30 seconds		TECO-U030S-E05		
		60 - 6 to 60 seconds		TECO-U060S-E05		
		100 - 10 to 100 seconds		TECO-U100S-E05		
		300 - 30 to 300 seconds		TECO-U300S-E05		
		1800 - 180 to 1800 seconds		TECO-U030M-E05		
	Off-Delay (TDCO)	-	24-60V 50/60Hz - DC 100-240V 50/60Hz - DC	24-60V AC/DC		100-240V AC/DC
		3 - 0,3 to 3 seconds		TDCO-U010S-E04		TDCO-U003S-E09
		10 - 1 to 10 seconds		TDCO-U003S-E04		TDCO-U010S-E09
		30 - 3 to 30 seconds		TDCO-U030S-E04		TDCO-U030S-E09
		60 - 6 to 60 seconds		TDCO-U060S-E04		TDCO-U060S-E09
		100 - 10 to 100 seconds		TDCO-U100S-E04		TDCO-U100S-E09
		300 - 30 to 300 seconds		TDCO-U300S-E04		TDCO-U300S-E09
	1800 - 180 to 1800 seconds	TDCO-U030M-E04	TDCO-U030M-E09			
	Start-Delta (TETCO)	30 - 3 to 30 seconds	24-28V 50/60Hz - DC	TETCO-U030S-D52		
			110-130V 50/60Hz - DC	TETCO-U030S-D61		
			220-240V 50/60Hz - DC	TETCO-U030S-D66		

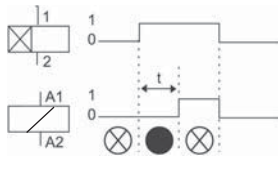
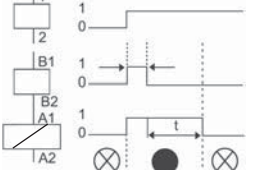
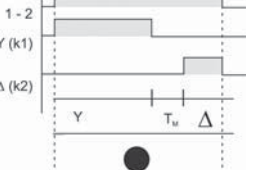
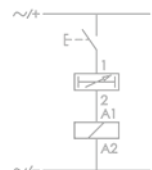
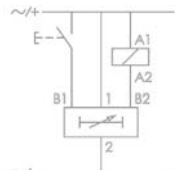
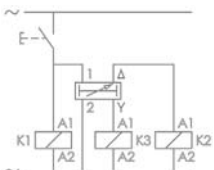
Functions	On-Delay TECO	Off-Delay TDCO	Start-Delta TETCO
Functional Diagram  Led On  Led Off			
Diagrams			

Mini contactors - Accessories

Printed circuit board link module

Illustrative picture	For use with	Description	Reference Code	Weight kg
	CWC07...16 CWCA0	- Direct mounting on the terminals - Allows direct mounting on printed circuit board - Same current capacity (up to 16A in AC-3 and 22A in AC-1)	CIC0	0.130

Reversing wiring kits for mini contactors CWC07 to CWC016

Rated operational current I _s AC - 3 (U _e ≤ 440V) A	Max. rated operational power of three-phase motors 50/60 Hz						Mini contactors	Reference Code	Weight kg
	220V 230V kW / hp	380V kW / hp	400V 415V kW / hp	440V kW / hp	500V kW / hp	660V 690V kW / hp	K1 = K2		
7	1.5 / 2	3 / 4	3 / 4	3.7 / 5	3.7 / 5	3.7 / 5	CWC07	ECC0-R	0.5
9	2.2 / 3	4 / 5	4 / 5	4.5 / 6	4.5 / 6	5.5 / 7.5	CWC09		
12	3 / 4	5.5 / 7.5	5.5 / 7.5	5.5 / 7.5	5.5 / 7.5	7.5 / 10	CWC012		
16	4 / 5	7.5 / 10	7.5 / 10	7.5 / 10	7.5 / 10	7.5 / 10	CWC016		



Star-delta wiring kits for mini contactors CWC07 to CWC016

Rated operational current I _s AC - 3 (U _e ≤ 440V) A	Max. rated operational power of three-phase motors 50/60 Hz			Mini contactors		Reference Code	Weight kg
	230-240V kW / hp	400-440V kW / hp	660-690V kW / hp	K1 = K2	K3		
12	3.7 / 5	5.5 / 7.5	7.5 / 10	CWC07	CWC07	ECC0-SD	0.5
18	3.7 / 5	7.5 / 10	11 / 15	CWC012			
25	5.5 / 7.5	11 / 15	18.5 / 25	CWC016	CWC09		



Mini contactors - Technical Data

Reference Code	CWC07	CWC09	CWC012	CWC016	CWC025	CWCA0
Standards	IEC/EN 60 947. DIN VDE 0660. UL. CSA					
Rated insulation voltage U_i IEC/EN 60 947. DIN VDE 0660 UL. CSA	690 V 600 V					
Rated impulse withstand voltage U_{imp}	4kV					
Rated operational frequency	25 - 400 Hz					
Degree of protection Main circuits Control circuits and auxiliary contacts	IP20 IP20					
Ambient temperature Operating temperature Storage temperature	-25°C to +55°C -55°C to +80°C					
Altitude Normal values 90 % I_n / 80 % U_n 80 % I_n / 75 % U_n	to 3000 m 3000 to 4000 m 4000 to 5000 m					
Overvoltage category / Pollution degree	III / 3					
Climatic proofing	IEC 60 680-2					
Pole number of main circuits	3					4
Rated operational voltage U_e	690V					690 V
Conv. thermal current I_{th} at < 55°C rated operational current I_n / AC-1	18 A	20 A	22 A	22 A	32 A	10 A
Rated operational current I_n AC-4 ($U_n \leq 440V$)	2.8	3.5	4.5	5	9	-
AC-3 Utilization Category Rated operational power						
220/230 V kW / hp	1.5 / 2	2.2 / 3	3 / 4	4 / 5	5.5 / 7.5	-
380 V kW / hp	3 / 4	4 / 5	5.5 / 7.5	7.5 / 10	11 / 15	-
400/415 V kW / hp	3 / 4	4.5 / 6	5.5 / 7.5	7.5 / 10	11 / 15	-
440 V kW / hp	3.7 / 5	4.5 / 6	5.5 / 7.5	7.5 / 10	11 / 15	-
500 V kW / hp	3.7 / 5	4.5 / 6	5.5 / 7.5	7.5 / 10	11 / 15	-
690 V kW / hp	3.7 / 5	5.5 / 7.5	7.5 / 10	7.5 / 10	11 / 15	-
Maximum numbers of auxiliary contacts	5				2	4
Short circuit rating max. fuse gL-gG (A)	20	20	25	25	35	10
Maximum electrical operations per hour						
AC-1 Ops/h	300					-
AC-3 Ops/h	600					-
AC-4 Ops/h	300					-
no load Ops/h	2500					2500
Mechanical lifespan Ops x 10 ⁶	10				3	10
Electrical lifespan (AC-3) Ops x 10 ⁶	1.4	1.3	1.2	1.1	0.6	-
Rated operational current I_n						
AC-15	220-230 V A	-	-	-	-	10
	380-400 V A	-	-	-	-	6
	415 V A	-	-	-	-	5
	500 V A	-	-	-	-	4
DC-13	24 V A	-	-	-	-	6
	48 V A	-	-	-	-	4
	110 V A	-	-	-	-	2
	220 V A	-	-	-	-	0.7
Control circuit reliability	-					$U_{c \min} = 17 V$ $I_{c \min} = 5 mA$
Terminal capacity	1 or 2 x (0.5...2.5)				1 or 2 x (1...2.5) 1 or 2 x (2.5...6.0)	1 or 2 x (0.5...2.5)
						
Tightening torque N.m	1...1.5				1.8	1...1.5

Control circuit

Reference Code	CWC07	CWC09	CWC012	CWC016	CWC025	CWCA0	
Coil consumption	AC	Pick-up VA	30			58	30
		Cos φ	0.8			0.8	0.8
		Sealing VA	2...3			4.5...5.8	2...3
		Cos φ	0.27			0.27	0.27
	DC - Standard consumption W	2.6...3.7			-	2.6...3.7	
DC - Low consumption W	1.7...2.7			-	1.7...2.7		
Operation time	Closing / Opening (AC) ms	8...20 / 6...13			13...16 / 13.5...17	8...20 / 6...13	
	Closing / Opening (DC) ms	35...45 / 7...12			-	35...45 / 7...12	
Coils rated voltage V	12-660VAC / 12-440VDC			12-660VAC	12-660VAC / 12-440VDC		
Coil operational limits	0.85...1.1						
Bifrequency coils	Pick-up xUs	0.5...0.8					
	Drop-out xUs	0.2...0.6					

Mini contactors - Technical Data

Auxiliary contact block BFC		
Terminal capacity Number of conductors and Cross section (min. and max.)	Flexible without cable lug (mm ²)	2x (0.5...2.5)
	Flexible without cable lug (mm ²)	2x (0.75...1.5)
	AWG Cables	(12...22)
Tightening torque Nm		08...1.5Nm
Conventional thermal current (I _{th})	A	10
Rated operational current (I _e) AC - 15	A	6/4(220/240V). 3/2(380/440V). 2(500V)
Rated operational current (I _e) DC - 13		1.5(24V). 0.5(60V). 0.2(220-240V)

Timing Relay		
Rated insulation voltage (U _i)	V	300
Supply voltage (U _e)	1 – 2 terminals	24...240 VDC/VAC 50/60 Hz (TECO)
		24...60 VDC/VAC 50/60 Hz (TDCO)
		100...240 VDC/VAC 50/60 Hz (TDCO)
		220-240 VAC 50/60Hz (TETCO)
		110-130 VAC 50/60Hz (TETCO)
Control Voltage (U _c) only TDCO - pg 18	2 – B1 terminals	24...60 VDC/VAC 50/60 Hz (TDCO)
		100...240 VDC/VAC 50/60 Hz (TDCO)
Voltage operational limits		0.85...1.1 x U _c (VAC)
		0.8...1.25 x U _c (VDC)
Consumption	mA	≤ 5
Minimum time for Reset (Recovery time)	ms	650
Minimum control time (only TDCO)	ms	50
Setting accuracy (% of the full scale value)	%	+/-5
Repeat Accuracy	%	+/-1
Changeover time Y - Δ	ms	50

Mini contactors - Technical Data

Electrical Lifespan

AC-4 ($U_e \leq 440VAC$)

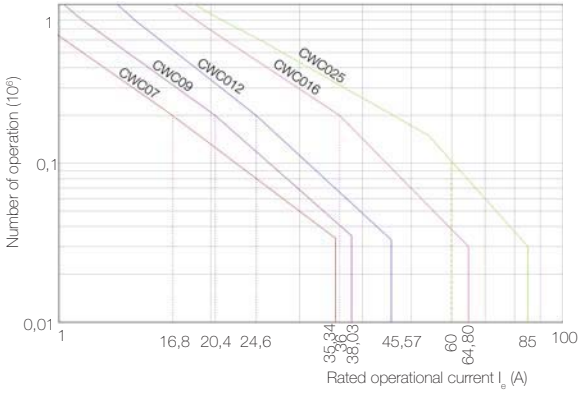

AC-3 ($U_e \leq 440VAC$)

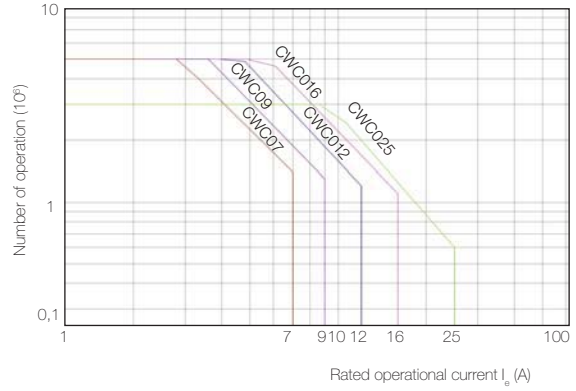

Mini contactors - Dimensions (mm)

CWC07 up to 16 and CWCA0 - (AC and DC coil)

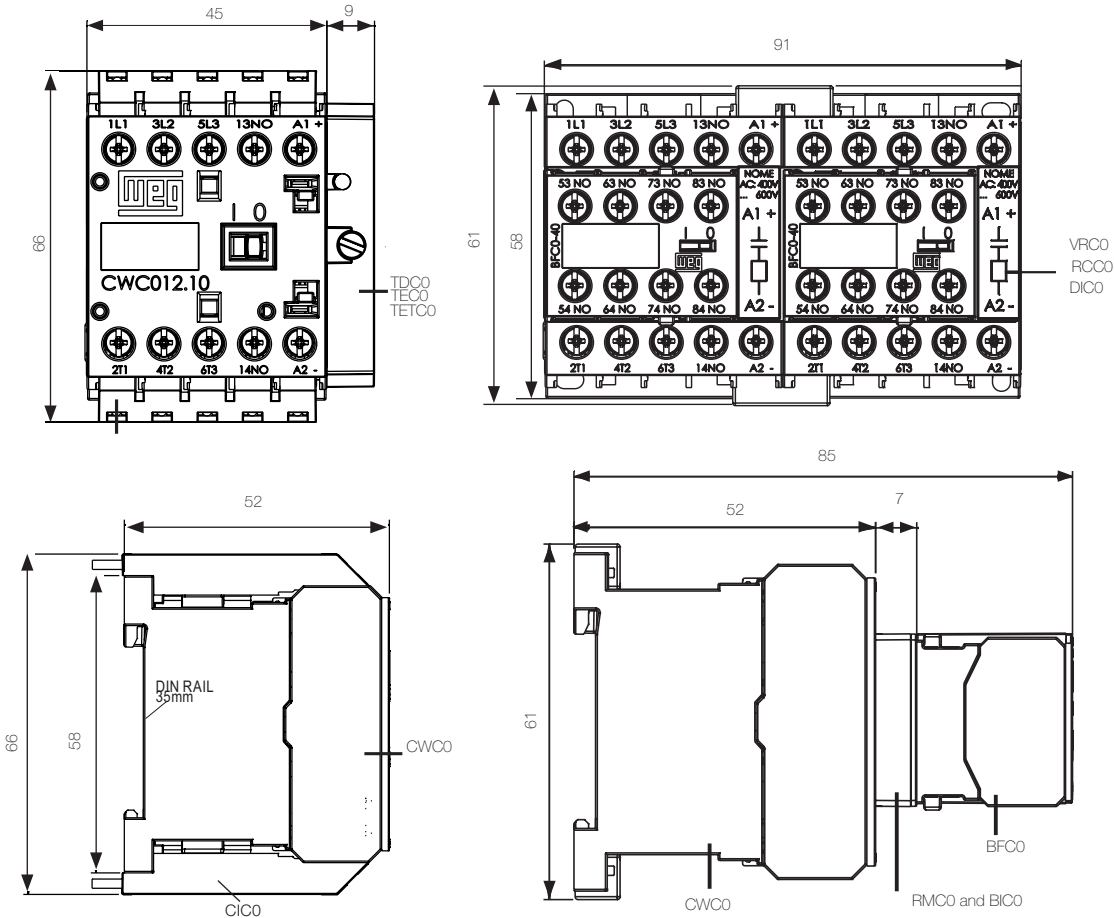

Mini contactors - Dimensions (mm)

CWC025

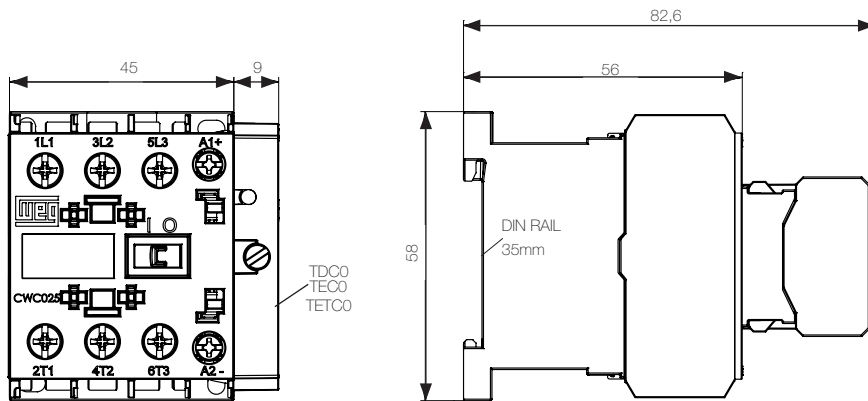

Mounting position of all mini contactors

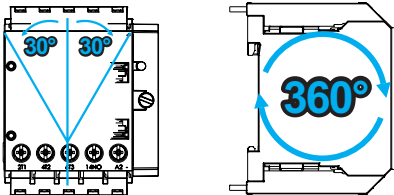

Contactors

The CWM general-purpose contactor line has been designed taking into consideration industrial duty and reliability.

Rated for inductive loads up to 800A or 440kW @380/400V, WEG can OFFer the suitable contactor for your application.

CWM contactors allow total panel space optimization, with only a few compact frame sizes from 4 to 440kW @ 400/415V. Reducing inventory is a “snap” with CWM’s common accessories. For example, side-mounted auxiliary contact blocks are the same from 9 to 300A (AC-3) @ 440V.

Designed for extended mechanical and electrical life, dependable switching in even the most heavy-duty applications can be achieved. No matter how demanding the application, all WEG contactors are tested and approved to be used under Type 1 and Type 2 short circuit coordination.

Ensuring global acceptance, all components conform to UL508 (USA and Canada), IEC60947 and CE.

All WEG contactors are manufactured to assure the highest quality manufacturing processes and component materials.

This way, WEG OFFers reliable solutions for low-voltage applications in electric panel assemblers, OEMs, distributors and end users.



Certifications



Contactors



Three-pole CWM contactors from 9 up to 250A (AC-3) - AC Coil

Rated operational current I_n AC-3 ($U_c \leq 440V$) A	Conv. thermal current $I_m = I_n$ AC-1 A	Max. rated operational power of three-phase motors 50/60 Hz ¹⁾						Auxiliary contacts per contactor		Auxiliary contact blocks separately delivered		Reference code	Weight kg
		220V 230V kW / hp	380V kW / hp	400V 415V kW / hp	440V kW / hp	500V kW / hp	660V 690V kW / hp	$\begin{matrix} \bullet 3 \\ \diagdown \\ \bullet 4 \end{matrix}$ NO	$\begin{matrix} \bullet 1 \\ \diagup \\ \bullet 2 \end{matrix}$ NC	BCXMF10 NO	BCXMF01 NC		
9	25	2.2 / 3	4 / 5	4 / 5	4.5 / 6	4.5 / 6	5.5 / 7.5	1	0	integrated	-	CWM9-10-30 ♦	0.360
								0	1	-	integrated	CWM9-01-30 ♦	
								1	1	integrated	1	CWM9-11-30 ♦	
								2	2	1	2	CWM9-22-30 ♦	
12	25	3 / 4	5.5 / 7.5	5.5 / 7.5	5.5 / 7.5	5.5 / 7.5	7.5 / 10	1	0	integrated	-	CWM12-10-30 ♦	0.360
								0	1	-	integrated	CWM12-01-30 ♦	
								1	1	integrated	1	CWM12-11-30 ♦	
								2	2	1	2	CWM12-22-30 ♦	
18	32	4.5 / 6	7.5 / 10	7.5 / 10	9.2 / 12.5	9.2 / 12.5	11 / 15	1	0	integrated	-	CWM18-10-30 ♦	0.360
								0	1	-	integrated	CWM18-01-30 ♦	
								1	1	integrated	1	CWM18-11-30 ♦	
								2	2	1	2	CWM18-22-30 ♦	
25	45	5.5 / 7.5	11 / 15	11 / 15	11 / 15	11 / 15	11 / 15	0	0	-	-	CWM25-00-30 ♦	0.390
								1	0	1	-	CWM25-10-30 ♦	
								0	1	-	1	CWM25-01-30 ♦	
								1	1	1	1	CWM25-11-30 ♦	
								2	2	2	2	CWM25-55-30 ♦	
32	60	9.2 / 12.5	15 / 20	15 / 20	15 / 20	15 / 20	18.5 / 25	0	0	-	-	CWM32-00-30 ♦	0.620
								1	0	1	-	CWM32-10-30 ♦	
								0	1	-	1	CWM32-01-30 ♦	
								1	1	1	1	CWM32-11-30 ♦	
								2	2	2	2	CWM32-22-30 ♦	
40	60	11 / 15	18.5 / 25	18.5 / 25	22 / 30	22 / 30	22 / 30	0	0	-	-	CWM40-00-30 ♦	0.650
								1	1	1	1	CWM40-11-30 ♦	
								2	2	2	2	CWM40-22-30 ♦	
50	90	15 / 20	22 / 30	22 / 30	30 / 40	30 / 40	30 / 40	0	0	-	-	CWM50-00-30 ♦	1.205
								1	1	1	1	CWM50-11-30 ♦	
								2	2	2	2	CWM50-22-30 ♦	
65	110	18.5 / 25	30 / 40	30 / 40	37 / 50	37 / 50	37 / 50	0	0	-	-	CWM65-00-30 ♦	1.215
								1	1	1	1	CWM65-11-30 ♦	
								2	2	2	2	CWM65-22-30 ♦	
80	110	22 / 30	37 / 50	45 / 60	45 / 60	45 / 60	45 / 60	0	0	-	-	CWM80-00-30 ♦	1.220
								1	1	1	1	CWM80-11-30 ♦	
								2	2	2	2	CWM80-22-30 ♦	
95	140	22 / 30	45 / 60	55 / 75	55 / 75	55 / 75	55 / 75	0	0	-	-	CWM95-00-30 ♦	1.525
								12	1	1	1	CWM95-11-30 ♦	
								2	2	2	2	CWM95-22-30 ♦	
105	140	30 / 40	55 / 75	55 / 75	55 / 75	55 / 75	55 / 75	0	0	-	-	CWM105-00-30 ♦	1.505
								1	1	1	1	CWM105-11-30 ♦	
								2	2	2	2	CWM105-22-30 ♦	
112	180	30 / 40	55 / 75	55 / 75	55 / 75	55 / 75	75 / 100	2	2	-	-	CWM102-22-30 ♦	2.4
180	225	55 / 75	90 / 125	90 / 125	110 / 150	110 / 150	110 / 150	2	2	-	-	CWM180-22-30 ♦	3.9
250	350	75 / 100	132 / 175	132 / 175	150 / 200	160 / 220	160 / 220	2	2	-	-	CWM250-22-30 ♦	6.0

To complete the reference code, replace “♦” with the appropriate coil voltage code ²⁾ :

Coil voltage codes	D02	D07	D13	D24	D25	D34	D35
50/60Hz	24V	48V	110V	230V	240V	400V	415V

Notes: 1) Some motors characteristics may vary according to each manufacturer.
 2) Other voltages available.
 3) For selection of accessories, check page 29.

Contactors



Three-pole CWM contactors from 9 up to 105A (AC-3) - DC Coil

Rated operational current I_n AC-3 ($U_n \leq 440V$)	Conv. thermal current $I_{th} = I_n$ AC-1	Max. rated operational power of three-phase motors 50/60 Hz ¹⁾						Auxiliary contacts per contactor		Auxiliary contact blocks separately delivered		Reference code	Weight kg
		220V 230V	380V	400V 415V	440V	500V	660V 690V			BCXMF10	BCXMF01		
		kW / hp	kW / hp	kW / hp	kW / hp	kW / hp	kW / hp	NO	NC	NO	NC		
9	25	2.2 / 3	4 / 5	4 / 5	4.5 / 6	4.5 / 6	5.5 / 7.5	1	0	integrated	-	CWM9-10-30♦	0.520
								0	1	-	integrated	CWM9-01-30♦	
								1	1	integrated	1	CWM9-11-30♦	
								2	2	1	2	CWM9-22-30♦	
12	25	3 / 4	5.5 / 7.5	5.5 / 7.5	5.5 / 7.5	5.5 / 7.5	7.5 / 10	1	0	integrated	-	CWM12-10-30♦	0.520
								0	1	-	integrated	CWM12-01-30♦	
								1	1	integrated	1	CWM12-11-30♦	
								2	2	1	2	CWM12-22-30♦	
18	32	4.5 / 6	7.5 / 10	7.5 / 10	9.2 / 12.5	9.2 / 12.5	11 / 15	1	0	integrated	-	CWM18-10-30♦	0.520
								0	1	-	integrated	CWM18-01-30♦	
								1	1	integrated	1	CWM18-11-30♦	
								2	2	1	2	CWM18-22-30♦	
25	45	5.5 / 7.5	11 / 15	11 / 15	11 / 15	11 / 15	11 / 15	0	0	-	-	CWM25-00-30♦	0.520
								1	0	1	-	CWM25-10-30♦	
								0	1	-	1	CWM25-01-30♦	
								1	1	1	1	CWM25-11-30♦	
								2	2	2	2	CWM25-22-30♦	
32	60	9.2 / 12.5	15 / 20	15 / 20	15 / 20	15 / 20	18.5 / 25	0	0	-	-	CWM32-00-30♦	0.640
								1	0	1	-	CWM32-10-30♦	
								0	1	-	1	CWM32-01-30♦	
								1	1	1	1	CWM32-11-30♦	
								2	2	2	2	CWM32-22-30♦	
40	60	11 / 15	18.5 / 25	18.5 / 25	22 / 30	22 / 30	22 / 30	0	0	-	-	CWM40-00-30♦	0.640
								1	1	1	1	CWM40-11-30♦	
								2	2	2	2	CWM40-22-30♦	
50	90	15 / 20	22 / 30	22 / 30	30 / 40	30 / 40	30 / 40	0	0	-	-	CWM50-00-30♦	1.463
								1	1	1	1	CWM50-11-30♦	
								2	2	2	2	CWM50-22-30♦	
65	110	18.5 / 25	30 / 40	30 / 40	37 / 50	37 / 50	37 / 50	0	0	-	-	CWM65-00-30♦	1.463
								1	1	1	1	CWM65-11-30♦	
								2	2	2	2	CWM65-22-30♦	
80	110	22 / 30	37 / 50	45 / 60	45 / 60	45 / 60	45 / 60	0	0	-	-	CWM80-00-30♦	1.463
								1	1	1	1	CWM80-11-30♦	
								2	2	2	2	CWM80-22-30♦	
95	140	22 / 30	45 / 60	55 / 75	55 / 75	55 / 75	55 / 75	0	0	-	-	CWM95-00-30♦	1.463
								12	1	1	1	CWM95-11-30♦	
								2	2	2	2	CWM95-22-30♦	
105	140	30 / 40	55 / 75	55 / 75	55 / 75	55 / 75	55 / 75	0	0	-	-	CWM105-00-30♦	1.463
								1	1	1	1	CWM105-11-30♦	
								2	2	2	2	CWM105-22-30♦	

To complete the reference code, replace “♦” with the appropriate coil voltage code ²⁾ :

Coil voltage codes(CWM9...25)	C02	C03	C07	C09	C12	C15
VDC	12	24	48	60	110	220



Coil voltage codes(CWM32...105)	C34	C37	C40	C44
VDC	24-28	42-50	110-130	208-240

Notes: 1) Some motors characteristics may vary according to each manufacturer.
 2) Other voltages available.
 3) Contactors CWM32-105 with DC coils do not need surge suppressor blocks.
 4) For selection of accessories, check page 29.

Contactors



Three-pole CWM contactors from 112 up to 300A (AC-3) - Electronic module AC/DC

Rated operational current I_e AC-3 ($U_e \leq 440V$) A	Conv. thermal current $I_{th} = I_e$ AC-1 A	Max. rated operational power of three-phase motors 50/60 Hz ¹⁾						Auxiliary contacts per contactor		Auxiliary contact blocks		Reference code	Weight kg
		220V 230V	380V	400 V 415V	440 V	500 V	690 V			BCXML	1NO+1NC		
		kW / hp	kW / hp	kW / hp	kW / hp	kW / hp	kW / hp	NO	NC				
112	180	30 / 40	55 / 75	55 / 75	55 / 75	55 / 75	75 / 100	2	2	2	CWM112-22-30 ♦	3.12	
150	225	45 / 60	75 / 100	75 / 100	90 / 125	90 / 125	110 / 150	2	2	2	CWM150-22-30 ♦	3.20	
180	225	50 / 75	90 / 125	90 / 125	110 / 150	110 / 150	110 / 150	2	2	2	CWM180-22-30 ♦	5.08	
250	350	75 / 100	132 / 175	132 / 175	150 / 200	160 / 220	160 / 200	2	2	2	CWM250-22-30 ♦	6.86	
300	410	90 / 125	150 / 200	160 / 220	185 / 250	200 / 270	200 / 270	2	2	2	CWM300-22-30 ♦	6.90	



To complete the reference code, replace “♦” with the appropriate coil voltage code ²⁾ :

Coil voltage codes	E03	E07	E10	E13	E16
50/60Hz / DC *	24-28V	60-72V	110-130V	208-250V	360-415V

* Surge suppressor is already integrated



Three-pole CWME contactors from 400 up to 800A (AC-3) - Electronic module AC/DC

Rated operational current I_e AC-3 ($U_e \leq 440V$) A	Conv. thermal current $I_{th} = I_e$ AC-1 A	Max. rated operational power of three-phase motors 50/60 Hz ¹⁾						Auxiliary contacts per contactor		Auxiliary contact blocks		Reference code	Weight kg
		220 V 230V	380V	400 V 415V	440 V	500 V	690 V			BCXML	1NO+1NC		
		kW / hp	kW / hp	kW / hp	kW / hp	kW / hp	kW / hp	NO	NC				
400	450	125 / 150	220 / 300	220 / 300	220 / 300	220 / 300	250 / 330	2	2	2	CWME400-22 ♦	10	
630	660	190 / 250	330 / 450	330 / 450	330 / 450	330 / 450	330 / 450	2	2	2	CWME630-22 ♦	23.2	
800	900	220 / 300	440 / 600	440 / 600	440 / 600	500 / 700	500 / 700	2	2	2	CWME800-22 ♦	23.3	

To complete the reference code, replace “♦” with the appropriate coil voltage code ²⁾ :

Coil voltage codes(CWME400)	E36	D80	D81	D82
50/60Hz / DC *	100-240VAC / 100-220VDC	-	-	-
50/60Hz *	-	265-347V	380-450V	440-575V

Coil voltage codes(CWME630/800)	E35	E39	D80	D81	D82
50/60Hz / DC *	100-127VAC / 100-110VDC	200-240VAC / 200-220VDC	-	-	-
50/60Hz *	-	-	265-347V	380-450V	440-575V

* Surge suppressor is already integrated

Notes: 1) Some motors characteristics may vary according to each manufacturer.
2) Other voltages available

Contactors



CWMC contactor for capacitor switching (AC-6b)

AC COIL (24. 48. 110. 230. 400. 415V. 50/60Hz) ¹⁾		CWMC25	CWMC32	CWMC50	CWMC65	
Reactive Power AC-6b (Temperature = 55 °C)	220 - 230 V	(kVAr)	10	15	25	30
	380 - 415 V		15	25	40	50
	440 V		20	30	45	60
	480 V		22	32	50	65
	660 - 690 V		25	40	65	87
AC-6b Current (I _n) (55°C)	(A)	27	39	66	79	
Thermal Current (I _{th}) (55°C)		45	60	90	110	
AC-6b Current (I _n) (70°C)		15	27	46	55	
Max Fuse (gL/gG)		50	63	100	125	
Cable cross section		mm ²	2 x 10	16 + 16	35 + 35	35 + 35
	AWG	2 x 7	6 + 6	2 + 2	2 + 2	
Tightening torque	N.m	1.6 ... 3	2.5 ... 4	4 ... 6	4 ... 6	
Max. operation per hour	ops/h.	120				
Max. Number of Auxiliary contacts		1	3	5		
Electrical Lifespan	Ops x 10 ⁵	100	100	100	100	
Dimensions (width/height/depth)	mm	45/116/114	55/127/125	66/145/185	66/145/185	
Coil consumption (AC) Pick-up/Sealing	(VA)	75/9.3	123/12.5	308/25	308/25	

- One auxiliary contact 1NO included in CWMC contactors.

- Examples of reference code: - CWMC25-10-30♦ ; - CWMC32-10-30♦ ; - CWMC50-10-30♦ ; - CWMC-65-10-30♦ .

Diagram

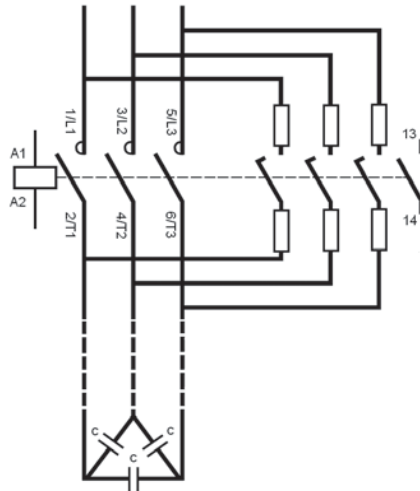

To complete the reference code, replace “♦” with the appropriate coil voltage code ²⁾ :













Coil voltage codes	D02	D07	D13	D24	D25	D34	D35
50/60Hz	24V	48V	110V	230V	240V	400V	415V

Note: 1) Other voltages on request





Contactors - Accessories

Auxiliary contact blocks for CWM9 to CWME800

- Terminal markings to EN 50 005 and EN 50 012
- Positive driven contacts in accordance with IEC/EN 60947-4-1 resp. IEC/EN60947-5-1

Illustrative picture	for use with	max.number of contacts/ contactor	Auxiliary contacts		Terminal markings	Reference Code	Weight kg
			NO	NC			
	CWM9...105	4 / CWM9...25 6 / CWM32...40	1	0		BCXMF10	0.015
			0	1		BCXMF01	
			1 ¹⁾	0		BCXMF10	
			0	1 ²⁾		BCXMF01	
	CWM9...300	8 / CWM50...105 8 / CWM112...300	2	0		BCXML20	0.050
			1	1		BCXML11	
			2	0		BCXML20 ³⁾	
			1	1		BCXML11 ³⁾	
	CWME400...800	8 / CWME400...800	1	1		BCXML11 CWME800	0.045
						BCXML11 CWME800 ³⁾	

Mechanical interlock for contactors

Illustrative picture	For use with	Reference Code	Weight kg
	CWM9...CWM105	BLIM9-105	0.050
		BLIM.02 ⁴⁾	
	CWM112...CWM300	BLIM112-300	0.150
	CWME400	BLIM CWME400	0.100
	CWME630...800	BLIM CWME800	15

- Notes: 1) Early-make contact
 2) Late-break contact
 3) For combination of more than 2 side-mounted auxiliary contacts
 4) This accessory allows mechanical and electrical interlock.

Contactors - Accessories

Individual spare coils

Illustrative picture	Description	For use with	Reference Code	Weight kg
	AC coil	CWM9...25. CWMC25	BCA4-25 ♦	0.065
		CWM32...40. CWMC32	BCA4-40 ♦	0.110
		CWM50...105. CWMC50...65	BCA-105 ♦	0.140
		CWM112	BCA-112 ♦	0.235
		CWM180	BCA-180 ♦	0.400
		CWM250	BCA-250 ♦	0.675
	DC coil	CWM9...25	BCC-25 ♦	0.120
		CWM32...40	BECC4-40 ♦	0.180
		CWM50...105	BECC-105 ♦	0.220
	Dual-voltage Coils AC/DC (contactors with electronic module)	CWM112...150	BCE-150 ♦	0.235
		CWM180	BCE-215 ♦	0.400
		CWM250...300	BCE-300 ♦	0.675
		CWME400	BCE400 ♦	1
CWME630...800		BCE800 ♦		

Contactors CWM9...300 and CWMC25...65 :

To complete the reference code, replace "♦" with the appropriate coil voltage code²⁾ :

Coil voltage codes(CWM9...250 and CWMC25...65)	D02	D07	D13	D24	D25	D34	D35
50/60Hz	24V	48V	110V	230V	240V	400V	415V

To complete the reference code, replace "♦" with the appropriate coil voltage code²⁾ :

Coil voltage codes (CWM9...25)	C02	C03	C07	C09	C12	C15
VDC	12	24	48	60	110	220

Coil voltage codes (CWM32...105)	C34	C37	C40	C44
VDC	24-28V	42-50V	110-130V	208-240V

To complete the reference code, replace "♦" with the appropriate coil voltage code²⁾ :

Coil voltage codes (CWM112...300)	E03	E07	E10	E13	E16
50/60Hz / DC *	24-28V	60-72V	110-130V	208-250V	360-415V

* Surge suppressor is already integrated

Contactors CWME400...800:

To complete the reference code, replace "♦" with the appropriate coil voltage code²⁾ :

Coil voltage codes (CWME400)	E36	D80	D81	D82
50/60Hz / DC *	100-240VAC / 100-220VDC	-	-	-
50/60Hz *	-	265-347V	380-450V	440-575V

Coil voltage codes (CWME630/800)	E35	E39	D80	D81	D82
50/60Hz / DC *	100-127VAC / 100-110VDC	200-240VAC / 200-220VDC	-	-	-
50/60Hz *	-	-	265-347V	380-450V	440-575V

* Surge suppressor is already integrated

Note: 1) Other voltages on request

Contactors - Accessories

Surge suppressors

- Direct connectable to coil terminals A1 - A2

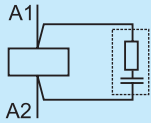
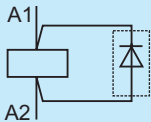
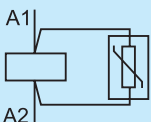
Illustrative picture	For use with	Voltage	Circuit diagram	Reference Code	Weight kg
	CWM9...40	24 - 48 V 50/60Hz		BAMRC4 D53	0.014
		50 - 127 V 50/60Hz		BAMRC5 D55	
		130 - 250 V 50/60Hz		BAMRC6 D63	
	CWM50...105	24 - 48 V 50/60Hz		BAMRC7 D53	
		50 - 127 V 50/60Hz		BAMRC8 D55	
		130 - 250 V 50/60Hz		BAMRC9 D63	
	CWM112...250	24 - 48 V 50/60Hz		BAMRC13 D53	
		50 - 250 V 50/60Hz		BAMRC14 D56	
	CWM9...25	12 - 600 VDC			
	CWM9...105	270 - 380 V 50/60Hz		BAMV1 D68	
				BAMV2 D73	
	CWM112...250	270 - 380 V 50/60Hz		BAMV3 D68	
		400 - 510 V 50/60Hz		BAMV4 D73	

Terminal Cover

- Protection against touching in accordance with relating installation rules

Illustrative picture	For use with	Description	Reference Code	Weight kg
	CWME400...800	1 kit with 2 parts	BLIM9-105	0.050
			BLIM112-300	0.150

Lug terminals

Illustrative picture	For use with	Description	Reference Code	Weight kg
	CWME400	1 kit with 3 pieces	BMJ CWME400	0.42
	CWME630...800	1 kit with 3 pieces	BMJ CWME400	1

Contactors - Accessories

Reversing wiring kits

Rated operational current Ie AC - 3 (U _e ≤ 440V) A	Maximum rated operational power of three-phase motors 50/60Hz			Contactors K1 = K2	Reference Code	Weight kg
	230-240V kW	400-440V kW	660-690V kW			
9	2.2	3.7	5.5	CWM9	EC-R-7.5	0.033
12	3.7	5.5	7.5	CWM12		
18	3.7	7.5	11	CWM18		
25	5.5	11	18.5	CWM25	EC-RC-11	0.5
32	7.5	15	22	CWM32	EC-RC-18.5	
40	11	18.5	30	CWM40		
50	15	22	37	CWM50	EC-RC-37	
65	18.5	30	45	CWM65		
80	22	37	55	CWM80		

Star-delta wiring kits

Rated operational current Ie AC - 3 (U _e ≤ 440V) A	Maximum rated operational power of three-phase motors 50/60 Hz			Contactors		Reference Code	Weight kg
	230-240V kW	400-440V kW	660-690V kW	K1 = K2	K3		
25	5.5	11	18.5	CWM18	CWM9	EC-SD-15	0.051
32	7.5	15	22	CWM18	CWM12		
40	7.5	18.5	30	CWM25	CWM18	EC-SD-22	0.5
50	11	22	37	CWM25	CWM18	EC-SD-25	
54	15	22	37	CWM32	CWM18	EC-SD-30	
60	15	30	45	CWM40	CWM25	EC-SD-37	
80	18.5	37	55	CWM50	CWM25	EC-SD-55	
85	22	45	75	CWM50	CWM32	EC-SD-90	
105	30	55	90	CWM65	CWM40		
140	37	75	110	CWM95	CWM50		
175	45	90	130	CWM105	CWM65		

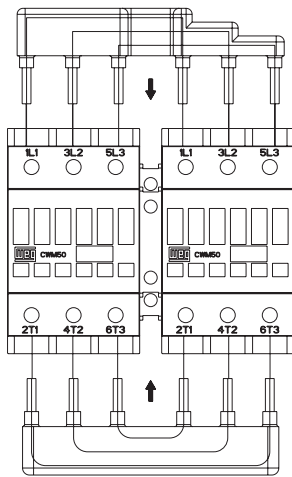

Wiring kit for reversing starters

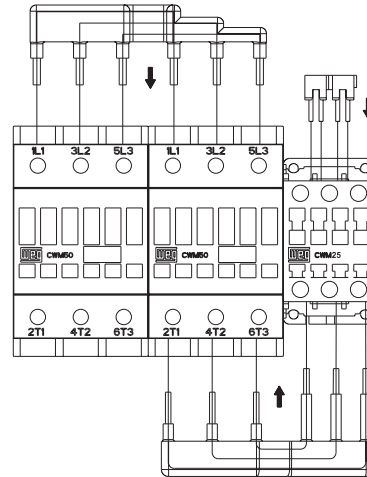

Wiring kit for star-delta starters

Contactors - Reversing Starters

Individual components for reversing starters

Maximum rated operational power of three-phase motors 50/60Hz				Individual components for reversing starters					
230-240 V	400-415 V	500 V	690 V	Contactor K1	Contactor K2	Spare auxiliary contacts		Mechanical interlock	Wiring kit
kW	kW	kW	kW	Type	Type	K1	K2		
2.2	4	5.5	5.5	CWM9-11	CWM9-11	-	-	Blim	EC-SD
3	5.5	7.5	7.5	CWM12-11	CWM12-11	-	-		
4	7.5	10	10	CWM18-11	CWM18-11	-	-		
5.5	11	15	15	CWM25-11	CWM25-11	-	-		
9	15	18.5	18.5	CWM32-11	CWM32-11	-	-		
11	18.5	25	30	CWM40-11	CWM40-11	-	-		
15	22	30	33	CWM50-11	CWM50-11	-	-		
18.5	30	40	45	CWM65-11	CWM65-11	-	-		
22	37	45	45	CWM80-11	CWM80-11	-	-		
25	45	55	55	CWM95-11	CWM95-11	-	-		
30	55	65	65	CWM105-11	CWM105-11	-	-		
30	55	75	80	CWM112-22	CWM112-22	1NO/1NC	1NO/1NC		
45	75	90	80	CWM150-22	CWM150-22	1NO/1NC	1NO/1NC		
55	90	110	132	CWM180-22	CWM180-22	1NO/1NC	1NO/1NC		
75	132	160	200	CWM250-22	CWM250-22	1NO/1NC	1NO/1NC		
90	160	200	200	CWM300-22	CWM300-22	1NO/1NC	1NO/1NC		

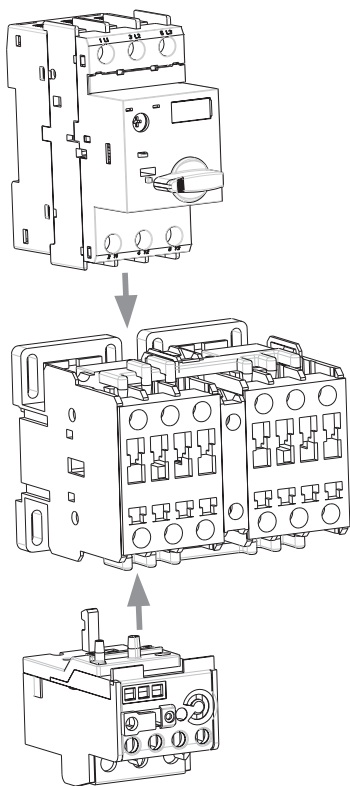

Equipment with Motor Protective Circuit Breaker **MPW** or Overload relay **RW**

Reversing starters

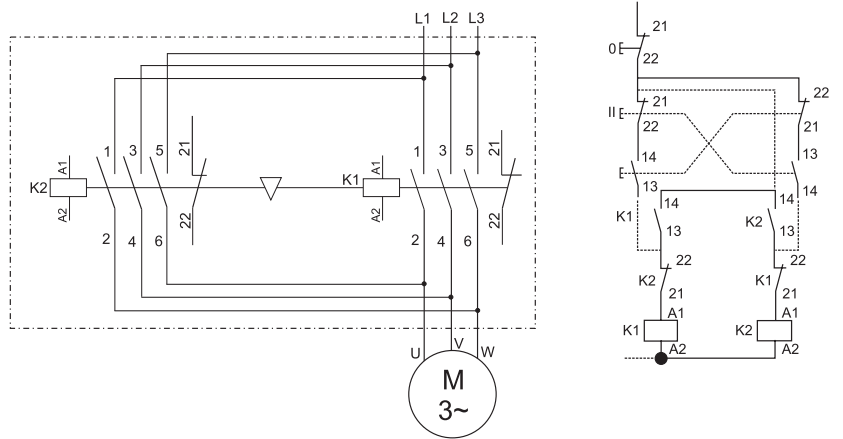

Contactors - Star-Delta Starters

Individual components for Star-Delta Starters

Maximum rated operational power of three-phase motors 50/60 Hz				Individual components for Star-Delta Starters							
230-240 V kW	400-415V kW	500 V kW	690 V kW	Main contactor K1	Delta contactor K2	Star contactor K3	Timer	Spare auxiliary contacts			Wiring kit
				Type	Type	Type		K1	K2	K3	
5,5	11	15	18,5	CWM18-10 + BCXMF10	CWM18-11	CWM9-11	RTW-ET	-	-	-	EC-SD
7,5	15	18,5	22	CWM18-10 + BCXMF10	CWM18-11	CWM12-11		-	-	-	
11	18,5	22	30	CWM25-00 + 2 x BCXMF10	CWM25-11	CWM18-11		-	-	-	
15	22	30	30	CWM25-00 + 2 x BCXMF10	CWM25-11	CWM18-11		-	-	-	
15	30	37	45	CWM40-00 + 2 x BCXMF10	CWM40-11	CWM25-11		-	-	-	
18,5	37	45	45	CWM50-00 + 2 x BCXMF10	CWM50-11	CWM25-11		-	-	-	
22	45	55	75	CWM50-00 + 2 x BCXMF10	CWM50-11	CWM32-11		-	-	-	
30	55	65	90	CWM65-00 + 2 x BCXMF10	CWM65-11	CWM40-11		-	-	-	
37	75	75	110	CWM95-00 + 2 x BCXMF10	CWM95-11	CWM50-11		-	-	-	
45	90	110	132	CWM105-00 + 2 x BCXMF10	CWM105-11	CWM65-11		-	-	-	
55	110	132	160	CWM150-22	CWM150-22	CWM65-11		2NC	1NO/NC	-	
75	132	160	200	CWM180-22	CWM180-22	CWM80-11		2NC	1NO/NC	-	
90	160	200	315	CWM250-22	CWM250-22	CWM105-11		2NC	1NO/NC	-	
110	200	250	-	CWM300-22	CWM300-22	CWM150-22		2NC	1NO/NC	1NO/NC	

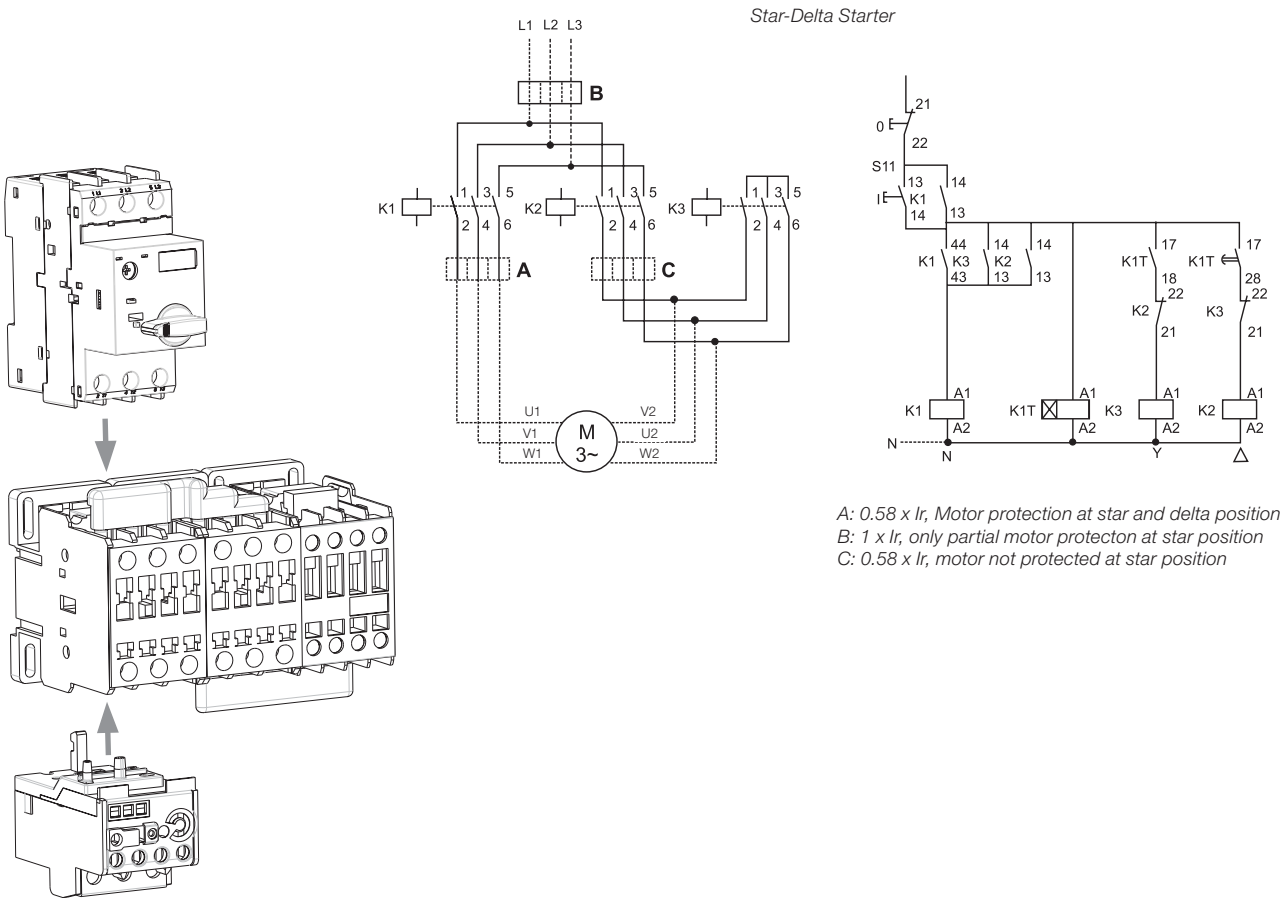

Equipment with Motor Protective Circuit Breaker **MPW** or Overload relay **RW**

Contactors - Technical Data

Reference code	CWM	9	12	18	25	32	40	50	65	80	95	105	112	150	180	250	300	
Standards		IEC/EN 60 947. DIN VDE 0660. UL. CSA											IEC/EN 60 947. DIN VDE 0660					
Rated insulation voltage U_i IEC/EN 60 947. DIN VDE 0660 UL. CSA		1000 V 600 V																
Rated impulse withstand voltage U_{imp}		6kV							8kV									
Rated operational frequency		25 - 400 Hz																
Degree of protection		Protection against direct contact from the front when operated by a perpendicular test finger (IEC 536)																
Main circuits		IP20			IP10									IP00				
Control circuits and auxiliary contacts		IP20																
Ambient temperature																		
Operating temperature		-25°C to +55°C																
Storage temperature		-55°C to +80°C																
Altitude																		
Normal values		up to 3000 m																
90% I_n / 80% U_n		3000 to 4000 m																
80% I_n / 75% U_n		4000 to 5000 m																
Overvoltage category / Pollution degree		III / 3																
Climatic proofing		Acc. IEC 60680-2																
Pole numbers of main circuits		3																
Rated operation voltage U_n		690 V							1000 V									
Conventional thermal current I_{th} at < 55°C rated operational current I_n /AC-1		25 A	25 A	32 A	45 A	60 A	60 A	90 A	110 A	110 A	140 A	140 A	180 A	225 A	225 A	350 A	410 A	
Rated operational current I_n AC-4 ($U_n \leq 440V$)		5	7	8	12	16	18.5	23	30	37	44	50	63	69	73	110	145	
AC-3 Utilization Category																		
Rated operational power																		
220-230 V	kW	2.2	3	4	6.5	9	11	15	18.5	22	25	30	30	45	55	75	90	
400-415 V	kW	4	5.5	7.5	11	15	18.5	22	30	37	45	55	55	75	90	132	160	
440 V	kW	4.5	5.5	9	12.5	15	22	30	37	45	55	55	90	110	150	185		
500 V	kW	5.5	7.5	10	15	18.5	25	30	40	45	55	65	75	90	110	160	200	
690 V	kW	5.5	7.5	10	15	18.5	30	33	45	45	55	65	80	80	132	200	200	
Short circuit rating max. fuse gL-gG (A)		25	35	35	50	63	80	100	125	125	160	200	224	250	250	400	500	
Max. electrical operational per hour																		
AC-1	Ops/h	1200	1200	1200	1200	1200	1200	1200	1200	1200	1200	1200	600	600	600	600	600	
AC-3	Ops/h	1200	1200	1200	1200	1200	1200	1200	1200	1200	1200	600	600	600	600	600	600	
AC-4	Ops/h	360	360	360	360	360	360	200	200	200	200	200	150	150	150	150	150	
no load	Ops/h	9000	9000	9000	9000	9000	9000	5000	5000	5000	5000	5000	4000	4000	4000	4000	4000	
Mechanical lifespan	Ops x 10 ⁶	10																
Electrical lifespan (AC - 3)	Ops x 10 ⁶	1.6	1.8	1.2				1.1					1.0					

Control circuit

Reference code	CWM	9	12	18	25	32	40	50	65	80	95	105	112	150	180	250	300					
Rated insulation voltage U_i		1000 V																				
Rated voltages (Standard coil) U_n 50/60Hz		12...660V											12...550V	-	24...690		-					
Rated voltages (Electronic Module) U_n 50/60Hz		24...500V																				
Rated voltages U_n DC		12...440V				24...240V																
Operation time ¹⁾	Closing/Opening (AC) ms	8...20 / 6...13			10...19 / 5...25				15...30 / 9...15					60...70 / 13...17								
	Closing/Opening (DC) ms	35...45 / 7...12			50...60 / 55...60														60...70 / 13...17		60...70 / 15...25	
Power consumption of the AC coil 50/60 Hz ¹⁾																						
Pick-up	(VA)	69.5			98			255					213		214		229					
	cos ϕ	0.85			0.69			0.32					0.71		0.68		0.73					
Sealing	(VA)	4...7.2			6.6...12.3			13.1...19.1					14.8		14.1		14.1					
	cos ϕ	0.28			0.34			0.54					0.26		0.27		0.26					
Power consumption of the coil - DC coils ¹⁾																						
Pick-up	(W)	3.8...7.5			240			340					166		154		171					
Sealing	(W)	3.8...7.5			6			6.5					2.4		2.4		2.5					
Number of terminals	AC coil	4			4			3					2									
	DC coil	3			4			3					2									
Coil operation limits 50/60Hz ¹⁾																						
Bifrequency coils ¹⁾	Pick-up	0.5...0.8			0.5...0.8			0.5...0.8					0.7...0.85		0.7...0.85		0.7...0.85					
	Sealing	0.2...0.6			0.2...0.6			0.25...0.6					0.4...0.6		0.4...0.6		0.4...0.6					

Note: 1) Values applicable for contactors CWM112...300 with electronic module. For contactors with standard coil only on request.





Contactors - Technical Data

Reference code	CWME400		CWME630	CWME800
Standards	IEC/EN 60 947. DIN VDE 0660. UL. CSA			
Rated insulation voltage U_i IEC/EN 60 947. DIN VDE 0660 UL. CSA			1000 V 600 V	
Rated impulse withstand voltage U_{imp}			6kV	
Rated operational frequency			25 - 400 Hz	
Degree of protection Main circuits Control circuits and auxiliary contacts			IP00 IP20	
Ambient temperature Operating temperature Storage temperature			-25°C to + 55°C -55°C to + 80°C	
Altitude Normal values 90% I_e / 80% U_e 80% I_e / 75% U_e			up to 3000 m 3000 to 4000 m 4000 to 5000 m	
Overvoltage category / Pollution degree			III / 3	
Climatic proofing			acc. to IEC 60680-2	
Pole numbers of main circuits			3	
Rated operation voltage U_e			690 V	
Conv. thermal current I_{th} at < 55°C rated operational current I_e /AC-1	450		660	900
Rated operational current I_e AC-4 ($U_e \leq 440V$)	300		400	630
AC-3 Utilization Category				
Rated operational power				
220-230 V	kW	125	190	220
400-415 V	kW	220	330	440
440 V	kW	220	330	440
500 V	kW	225	330	500
690 V	kW	250	330	500
Short circuit rating max. fuse gL-gG (A)	630		800	1000
Max. electrical operational per hour				
AC-1	Ops/h	300	300	300
AC-3	Ops/h	1200	1200	1200
AC-4	Ops/h	150	150	150
no load	Ops/h	1200	1200	1200
Mechanical lifespan Ops x 10 ⁶			5	
Electrical lifespan (AC - 3) Ops x 10 ⁶		0.5		0.6

Control circuit

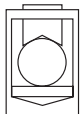
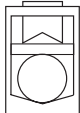
Reference code	CWME400		CWME630	CWME800
Voltage ranges	100-240 VAC 50/60Hz 100-220 VDC		100-127 VAC 50/60Hz 100-110 VDC	200-240 VAC 50/60Hz 200-220 VDC
Coil Operation Limit	0.85...1.1 x U_e			
Pick-Up (V)	77		77	150
Drop-Out (V)	48		48	51
Consumption	Voltage (V)	110	230	230
	Closing (VA)	571		1000
	Closed (VA)	14		29
	Dissipation (W)	4.4	5	6.3
Number of terminals			2	

Contactors - Technical Data

Reference code	CWM9 to CWM18	CWM25	CWM32 and CWM40	CWM50 to CWM80	CWM95 and CWM105	CWM112 and CWM150	CWM180	CWM250 and CWM300	CWME400	CWME630 and CWME800
Main terminal capacity (mm²)										
Solid, stranded and finely stranded without end sleeve Finally stranded with end sleeve		2x (1...2.5) 2x (2.5...6) 2x (0.25...2.5) 2x (2.5...6)	2x (1...2.5) 2x (2.5...10) 2x (1...2.5) 2x (2.5...10)	-	-	-	-	-	-	-
AWG-Wire		2x (20...13) 2x (13...10)	2x (17...13) 2x (13...7)	-	-	-	-	-	-	-
One conductor on top		-	0.75...16 0.75...16 1...16 1...16	1...35 1...35 1.5...35 1.5...35	1.5...50 1.5...50 2.5...50 2.5...50	-	-	-	-	-
AWG-Wire		-	18...6	17...2	15...1	-	-	-	-	-
One conductor on bottom		-	1...16 1...16 1.5...16 1.5...16	2.5...35 2.5...35 6...35 6...35	4...35 4...35 6...35 6...35	-	-	-	-	-
AWG-Wire		-	16...6	13...2	11...2	-	-	-	-	-
Two conductors		on top								
Solid Stranded with end sleeve Stranded without end sleeve Finally stranded		-	0.75...16 0.75...16 1...16 1...16	1...35 1...35 1.5...35 1.5...35	1.5...50 1.5...50 2.5...50 2.5...50	-	-	-	-	-
AWG-Wire		-	18...6	16...2	16...1	-	-	-	-	-
		on bottom								
Solid Stranded with end sleeve Stranded without end sleeve Finally stranded		-	1...16 1...16 1.5...16 1.5...16	2.5...35 2.5...35 6...35 6...35	4...35 4...35 6...35 6...35	-	-	-	-	-
AWG-Wire		-	16...6	14...2	10...2	-	-	-	-	-
Solid and stranded with end sleeve Bar		-	-	-	-	2 x (25...70) 2 x (15x3)	2 x (50...120) 2 x (20x3)	2 x (50...150) 2 x (30x5)	2 x (120...185) 2 x (30x6)	2 x (185...300) 2 x (40x10)
Tightening torque	(N.m)	1...1.7	1.6...3	2.5...4	4...6	5...6.5	10	13	17	23

Auxiliary contacts - Contactors CWM

Reference code	CWM9	CWM12	CWM18	BCXMF...	BCXML...
Rated insulation voltage U_i IEC/EN 60 947 (V) UL/CSA (V)				1000 600	1000 600
Rated operational voltage U_e (V)				690	690
Conv. thermal current I_{th} (A)				16	10
Rated operational current I_e AC-15 220 - 240 V (A) 380 - 400 V (A) 415 V (A) 500 V (A) UL/CSA DC-13 24 V (A) 48 V (A) 110 V (A) 220 V (A) UL/CSA				10 6 5 4 A600 6 4 2 0.7 P600	6 4 3.5 2.5 A600 6 4 2 0.7 Q600
Making capacity I_m AC-15/AC-11 AC-13/DC-11	U _e ≤ 400 V 50/60 Hz (A) U _e ≤ 220 V DC (A)			250 250	90 90
Breaking capacity I_e AC-15/AC-11 AC-13/DC-11	U _e ≤ 400 V 50/60 Hz (A) U _e ≤ 220 V DC (A)			250 2	60 0.95
Short circuit protection max. fuse gL/gG (A)				10	10
Control circuit reliability	I _e min = 5 mA. U _e min = 17 V				
Electrical lifespan	Ops				
Mechanical lifespan	Ops				

Contactors - Technical Data

Auxiliary contacts - Contactors CWME

Reference code		BCXML11 CWME800 / BCXMR11 CWME800	
Conv. thermal current I_{th}	(A)	16	
Rated operational current I_e AC Category (A600)	110V	AC-15 6	AC-12 10
	220V	5	10
	440V	3	5
	600V	3	5
DC Category (P600)	24V	DC-13 6	DC-12 5
	48V	3	3
	110V	1.2	1.3
	220V	0.2	0.25
Mechanical Lifespan		Ops x 10 ⁶	
		10	
Electrical Lifespan Operations x 10 ⁶	AC-15	0.5	
	AC-12	0.25	
	DC-13 / DC-12	0.5	
Max. electrical operational per hour		1800	

Terminal markings to EN 50012

	Distinctive number and version of combination	NO	NC	Reference code	Additional auxiliary contact blocks
Without auxiliary contact					
	10E	1	0	CWM9-10 CWM12-10 CWM18-10	-
	01E	0	1	CWM9-01 CWM12-01 CWM18-01	-
Front mounting auxiliary contact blocks BCXMF10 or BCXMF01					
	11E	1	1	CWM9-10 CWM12-10 CWM18-10	+BCXMF01
	21E	2	1	CWM9-10 CWM12-10 CWM18-10	+BCXMF10+BCXMF01
	12E	1	2	CWM9-10 CWM12-10 CWM18-10	+ 2 BCXMF01
	31E	3	1	CWM9-10 CWM12-10 CWM18-10	+ 2 BCXMF10 +BCXMF01
	41E	4	1	CWM9-10 CWM12-10 CWM18-10	+ 3 BCXMF10 +BCXMF01







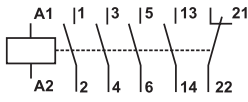
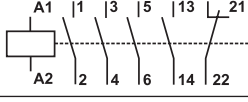

Contactors - Technical Data

Terminal markings to EN 50012

	Distinctive number and version of combination	NO	NC	Reference code	Additional auxiliary contact blocks
Front mounting auxiliary contact blocks BCXMF10 or BCXMF01					
	22E	2	2	CWM9-10 CWM12-10 CWM18-10	+ 2 BCXMF01 +BCXMF10
	32E	3	2	CWM9-10 CWM12-10 CWM18-10	+ 2 BCXMF01 +2 BCXMF10
	13E	1	3	CWM9-10 CWM12-10 CWM18-10	+ 3 BCXMF01
	23E	2	3	CWM9-10 CWM12-10 CWM18-10	+ 3 BCXMF01 +BCXMF10
Side mounting auxiliary contact blocks each with two contacts					
	11E	1	1	CWM25-00 to CWM105-00	+BCXML11
	31E	3	1	CWM25-00 to CWM105-00	+BCXML11 +BCXML20
	22E	2	2	CWM25-00 to CWM105-00	+2 BCXML11
Without auxiliary contact					
	10E	0	0	CWM25-00 to CWM105-00	-

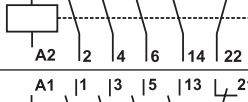
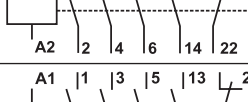
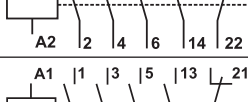
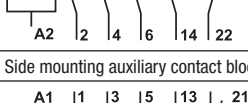
Contactors - Technical Data

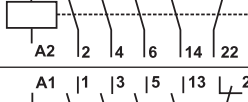
Terminal markings to EN 50012

	Distinctive number and version of combination	NO	NC	Reference code	Additional auxiliary contact blocks
Front mounting auxiliary contact blocks BCXMF10 or BCXMF01					
	11E	1	1	CWM25-00 to CWM105-00	+BCXMF01
	21E	2	1	CWM25-00 to CWM105-00	+BCXMF10+BCXMF01
	12E	1	2	CWM25-00 to CWM105-00	+ 2 BCXMF01
	31E	3	1	CWM25-00 to CWM105-00	+ 2 BCXMF10 +BCXMF01
	41E	4	1	CWM25-00 to CWM105-00	+ 3 BCXMF10 +BCXMF01
	22E	2	2	CWM25-00 to CWM105-00	+ 2 BCXMF01 +BCXMF10
	32E	3	2	CWM25-00 to CWM105-00	+ 2 BCXMF01 +2 BCXMF10
	13E	1	3	CWM25-00 to CWM105-00	+ 3 BCXMF01
	23E	2	3	CWM25-00 to CWM105-00	+ 3 BCXMF01 +BCXMF10
Side mounting auxiliary contact blocks each with two contacts					
	11E	1	1	CWM25-00 to CWM105-00	+BCXML11
	31E	3	1	CWM25-00 to CWM105-00	+BCXML11 +BCXML20
	22E	2	2	CWM25-00 to CWM105-00	+2 BCXML11

Contactors - Technical Data

Electrical Lifespan

AC-3 ($U_e \leq 440VAC$)

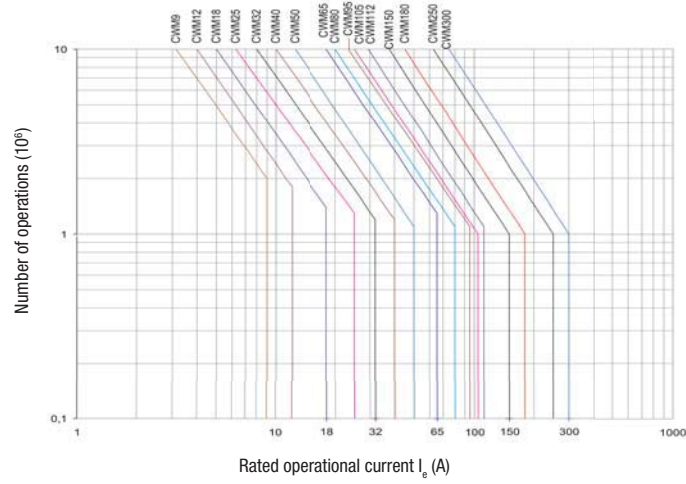

AC-4 ($U_e \leq 440VAC$)

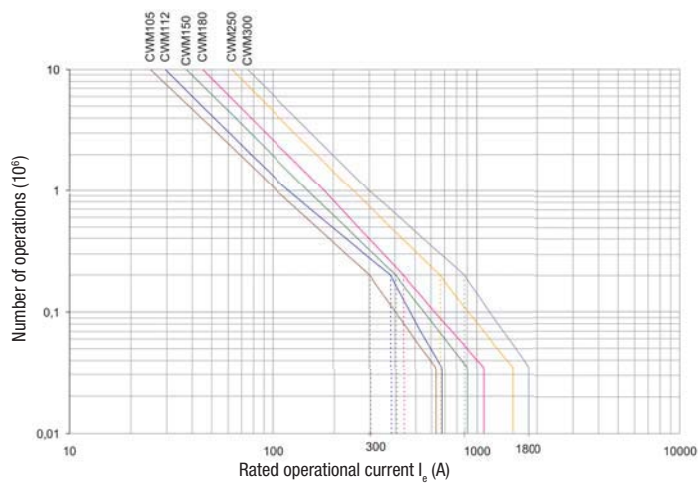
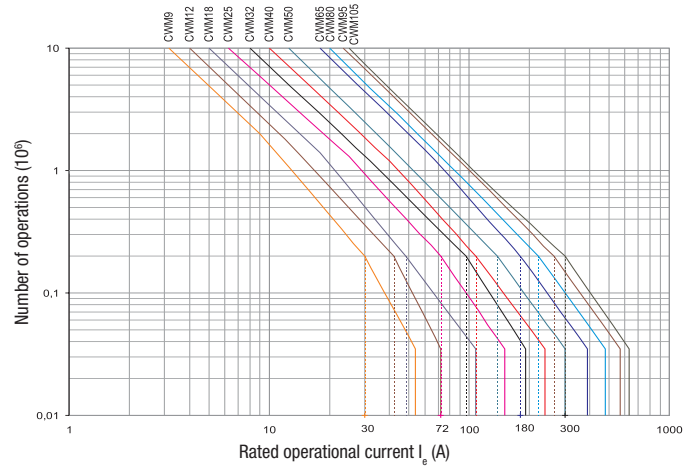

Contactors - Technical Data

Electrical Lifespan

$U_e \leq 220-240 \text{ VAC}$

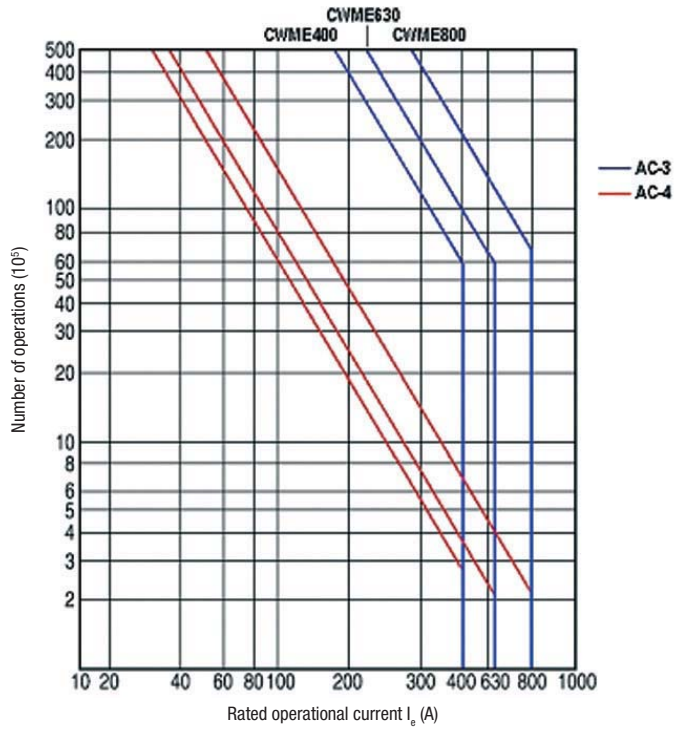

$U_e \leq 380-440 \text{ VAC}$

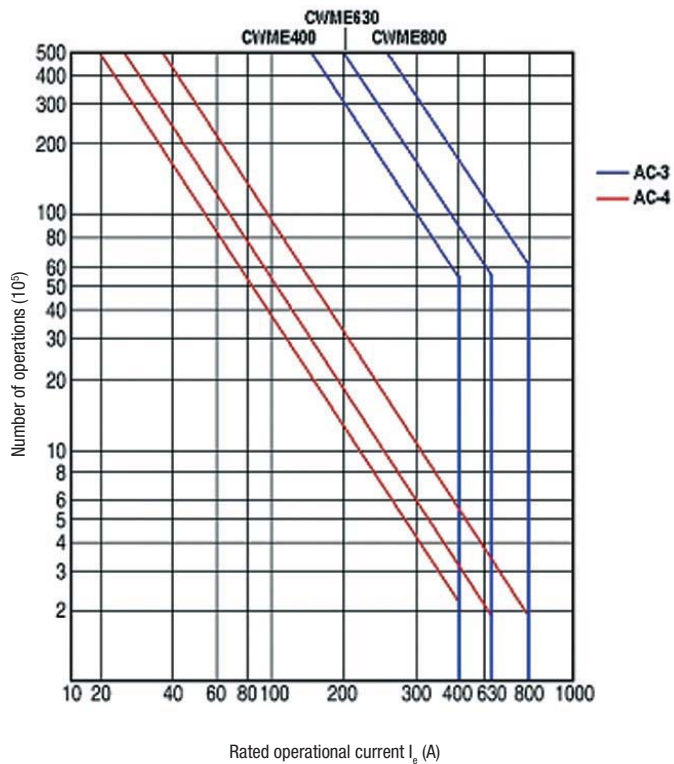

Contactors – Dimensions (mm)

Coil	
AC	DC
A = 87	A = 117

CWM9, CWM12, CWM18

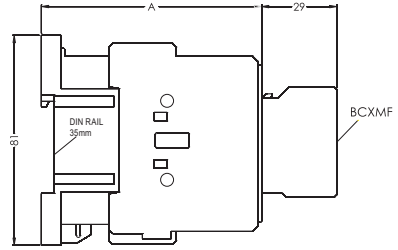
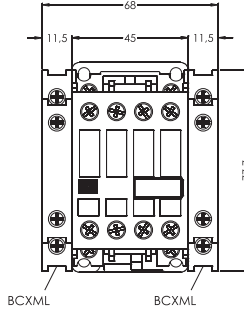
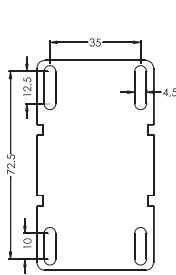

Coil	
AC	DC
A = 87	A = 117

CWM25

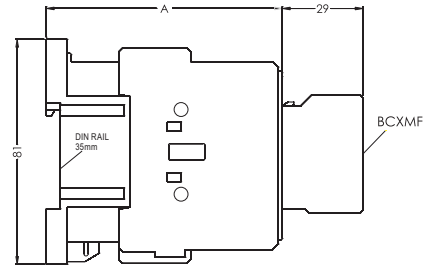
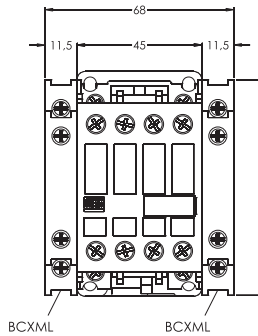
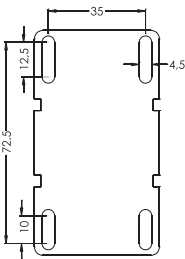

Coil	
AC	DC
A = 98	A = 134

CWM32 and CWM40

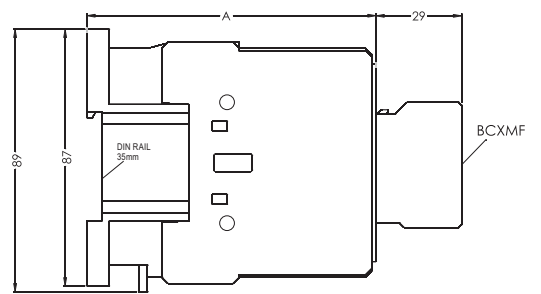
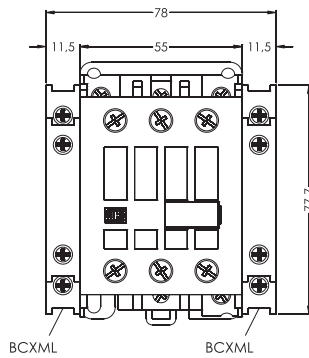
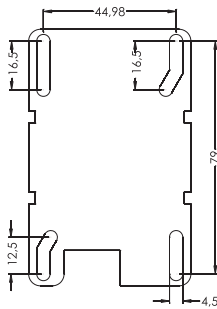

Coil	
AC	DC
A = 116	A = 144

CWM50, CWM65 and CWM80

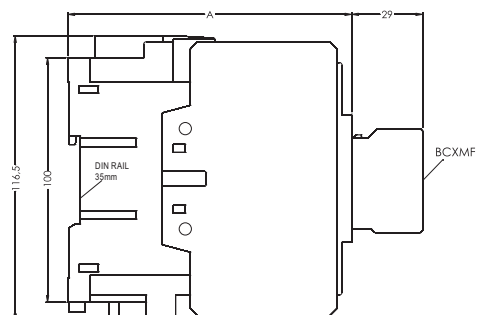
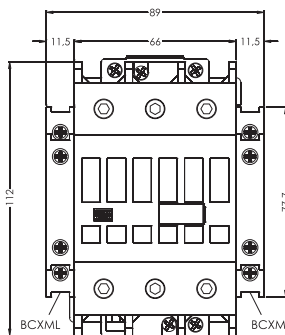
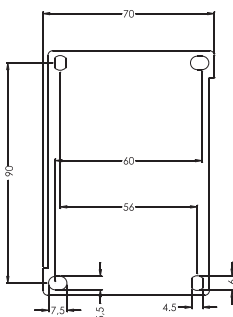

Contactors – Dimensions (mm)

Coil	
AC	DC
A = 126	A = 154

CWM95 and CWM105

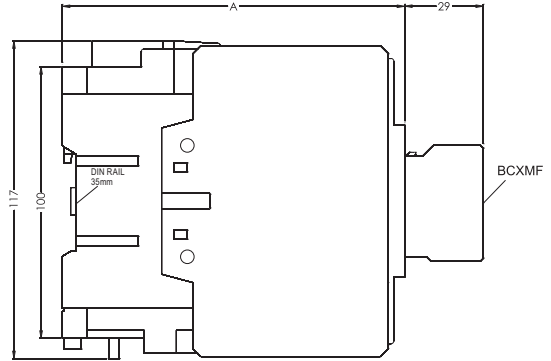
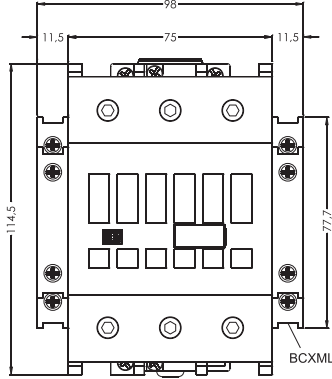
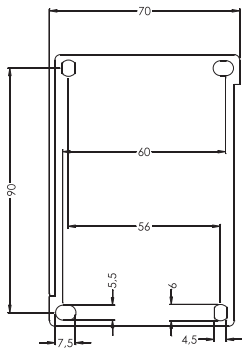

CWM112 and CWM150

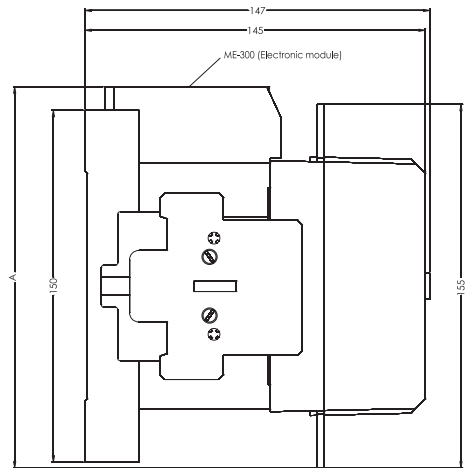
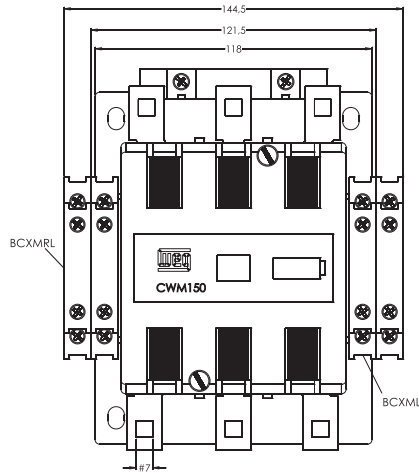
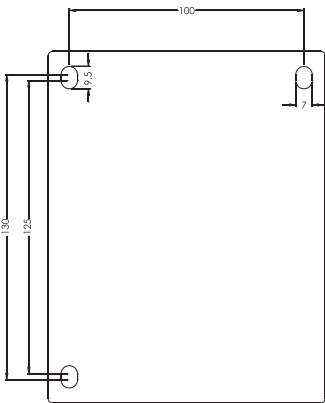

CWM180

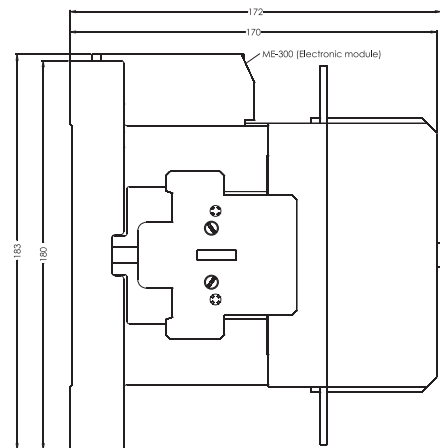
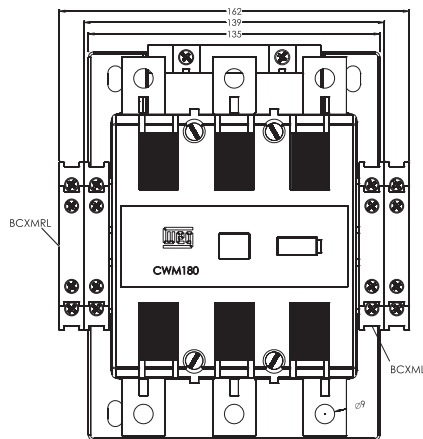
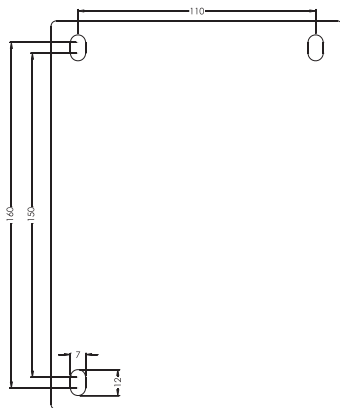

Contactors – Dimensions (mm)

CWM250 and CWM300

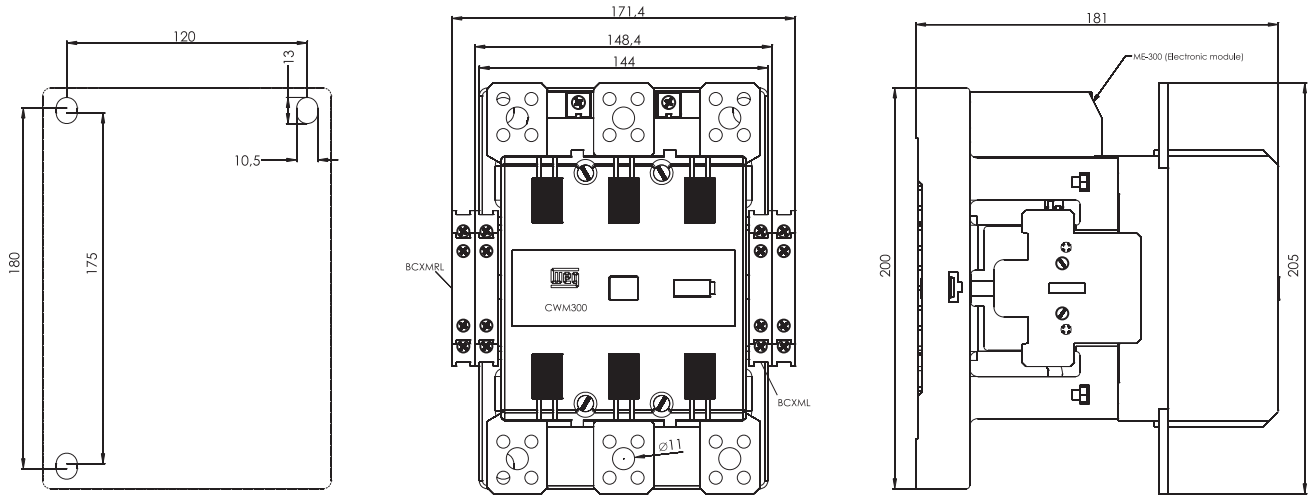

BLIM9-105

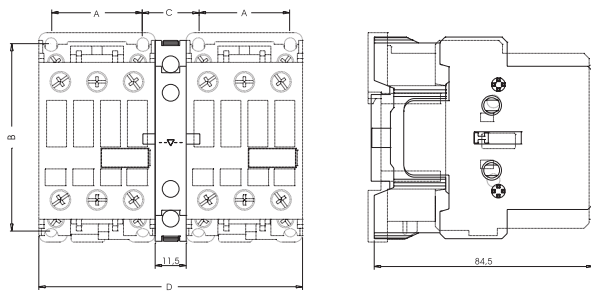

Models	A	B	C	D
CWM9...25	35	72,5	22	102
CWM32...40	45	79	22	122
CWM50...80	57	90	21	144
CWM95...105	57	90	29,8	153

BLIM112-300

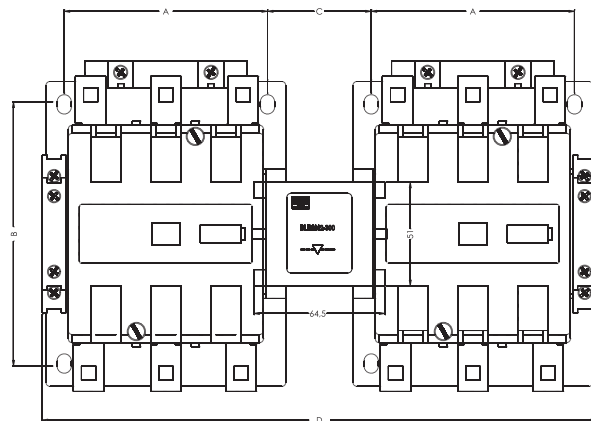

Models	A	B	C	D
CWM112...150	100	130	51	272,5
CWM180	110	160	58,5	303,5
CWM250...300	120	180	57	325,4

Mounting position

CWM9...105

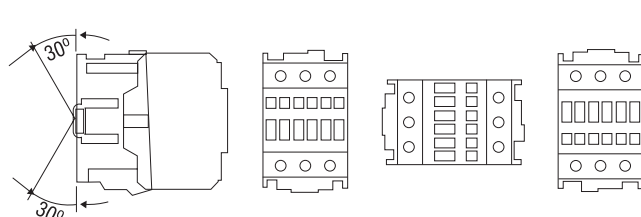

CWM112...300

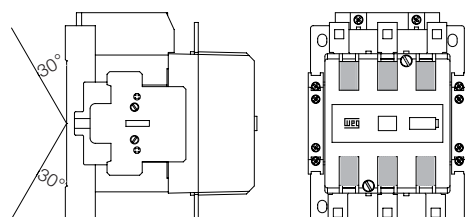

Contactors – Dimensions (mm)

CWME400

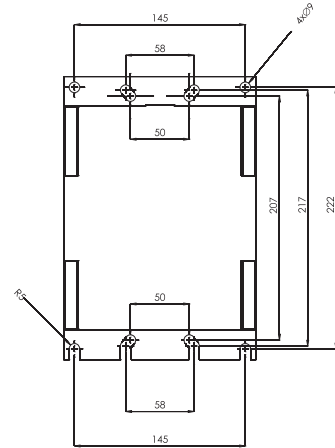
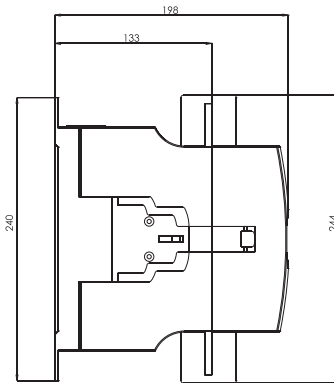
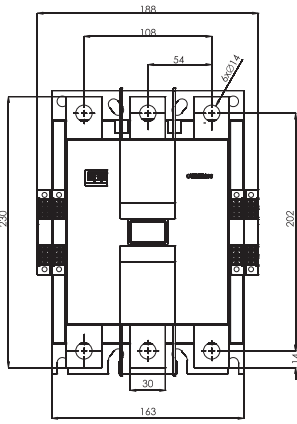

CWME630 and CWME800

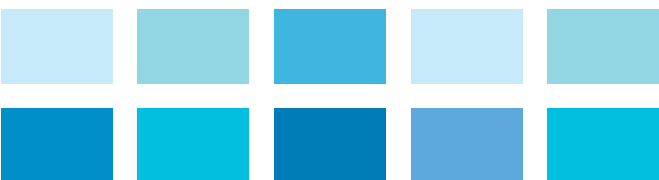
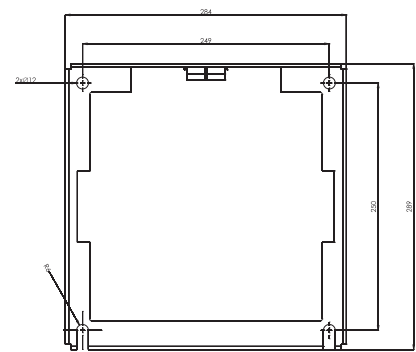
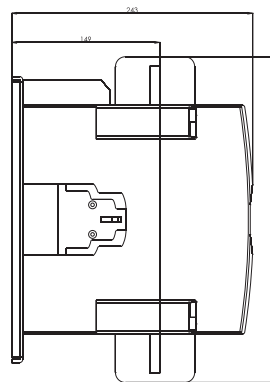
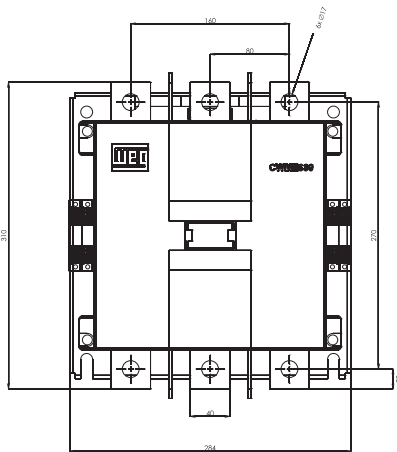

Contactors – Dimensions (mm)

BLIM CWME400

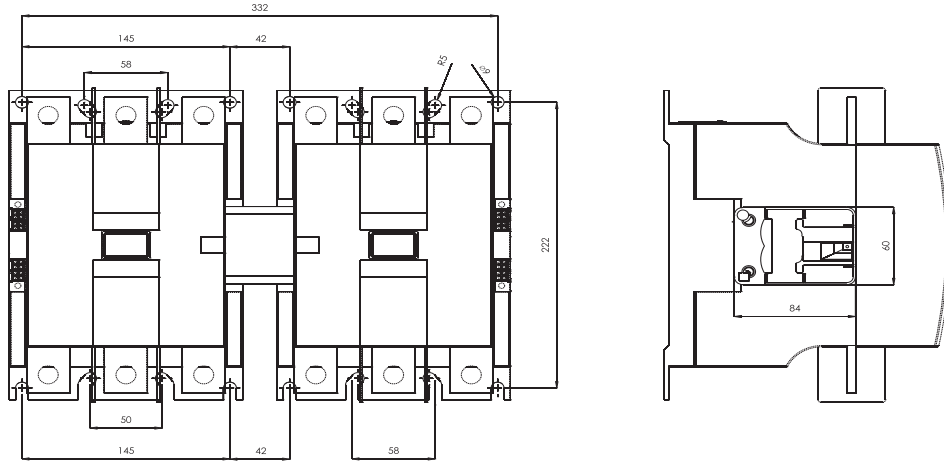

BLIM CWME800

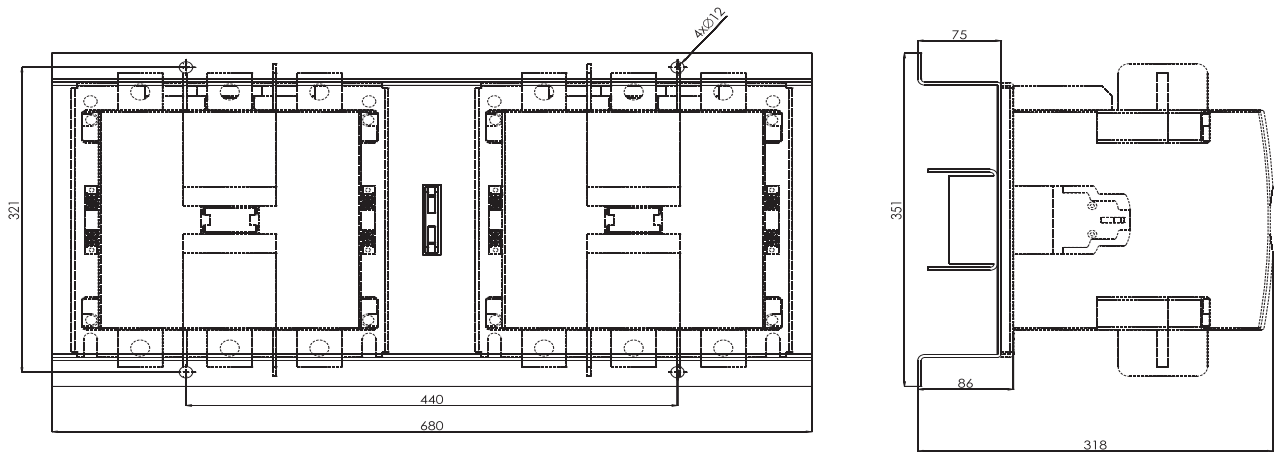

Contactors – Dimensions (mm)

CWME400 + BMJ

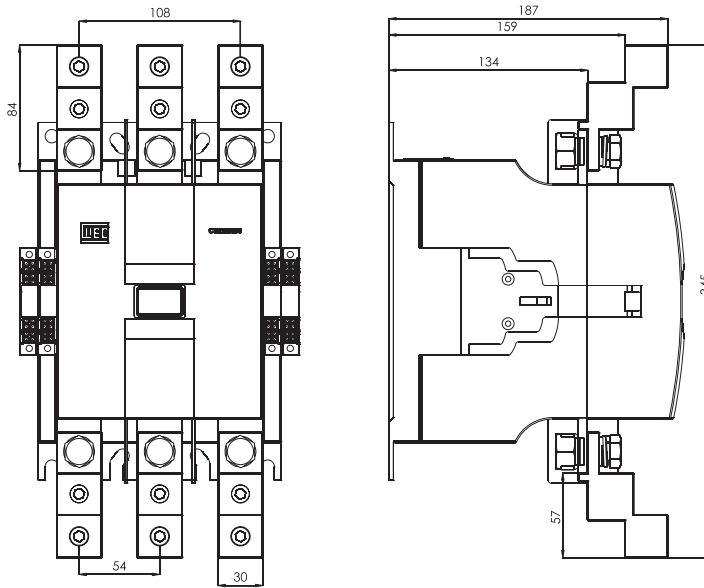

CWME 630...800 + BMJ

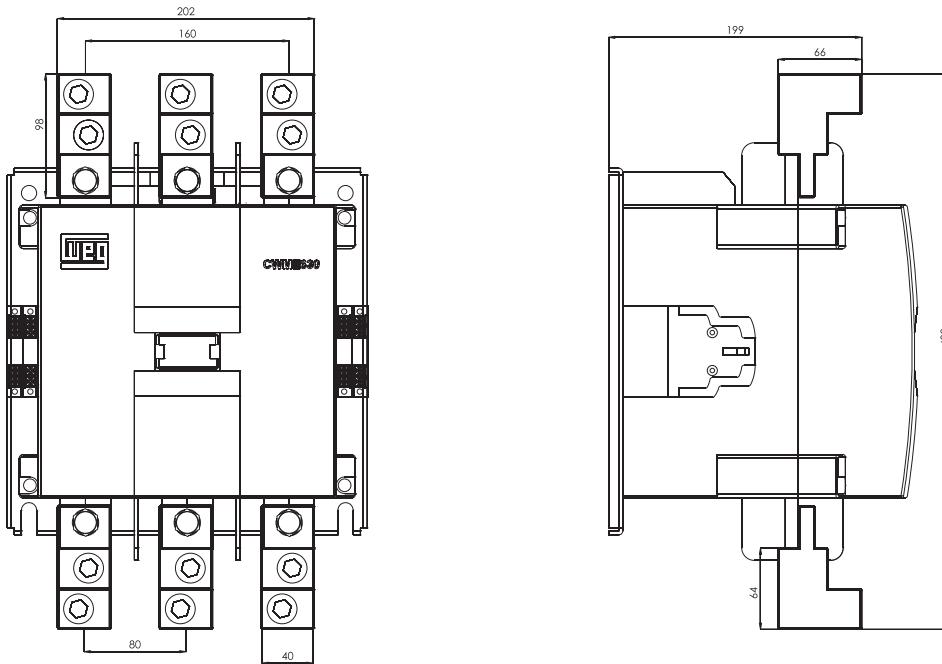

Mounting position

CWME 400...800

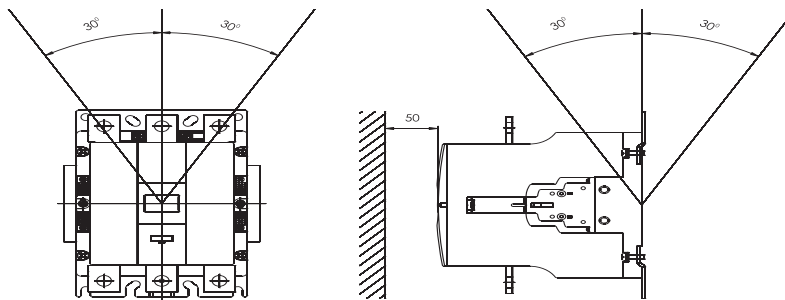

Contactors – Dimensions (mm)

CWMC25

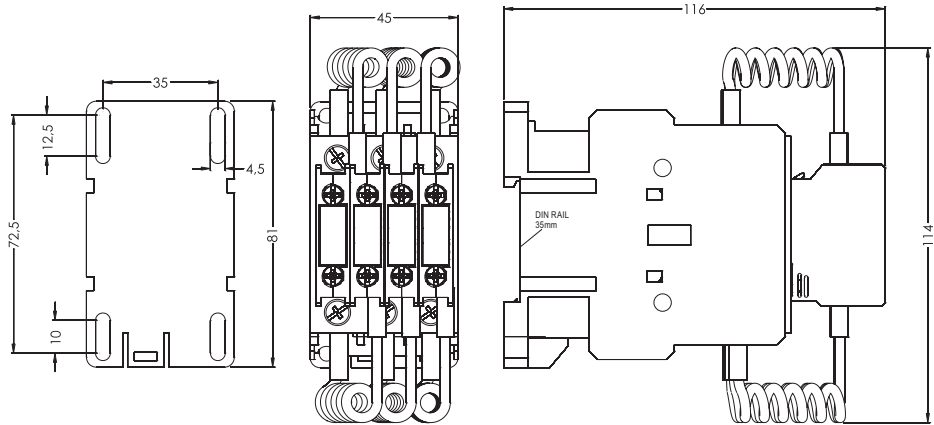

CWMC32

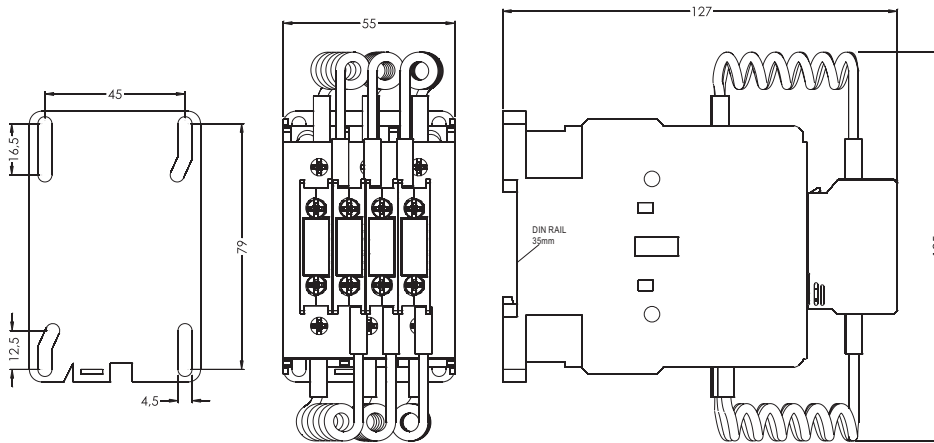

CWMC50 and CWMC65

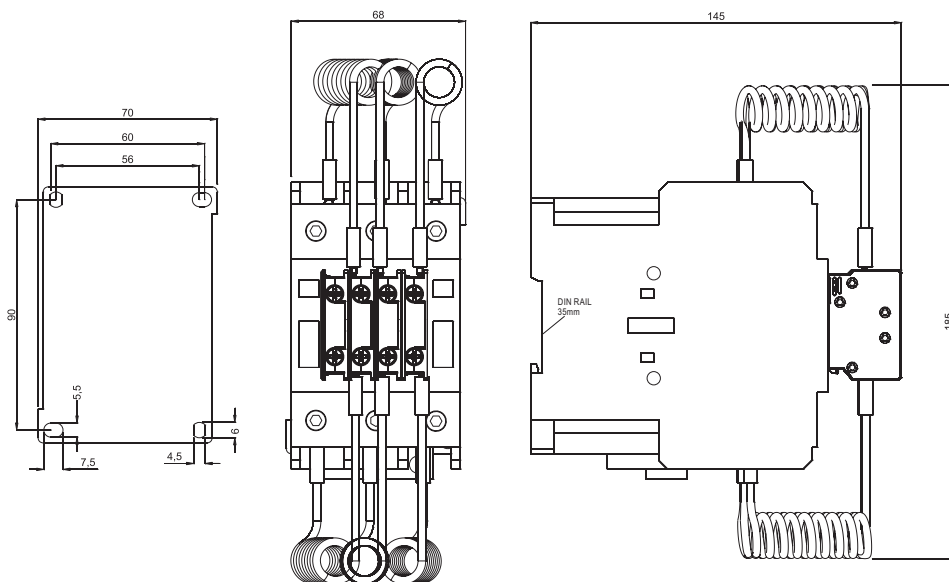

Overload Relays

RW overload relays are important equipment within WEG Controls' range of products. As usual for WEG products, an extended operational service life is one of the main features you can find in RW overload relays. WEG's RW Class 10 Thermal Overload Relays are designed to be used with, and as perfect compliment to the minicontactors and contactors. Effectively, RW overload relays can be mounted directly to WEG minicontactors and contactors, assuring electrical and mechanical operation as an open across-the-line starter. Accessories are also available for separate mounting.

RW overload relays are fitted with fixed bimetallic parts, which eliminate any need for heater elements for field installation or future upgrading to a more efficient motor. All sizes provide complete motor protection by OFFering:

- Ambient temperature compensation,
- Phase failure sensitivity protection.

Dial FLC Setting

The trip-current is set via an infinitely adjustable dial designed with the motor's full load current.

Temperature Compensation

Because RW overload relays include a fourth bimetallic strip in addition to the three that are directly heated by the motor current, ambient temperature variations in the range of -20°C to +60°C are no obstacle for accurate protection of your motors even under the toughest conditions.

Phase Failure Sensitivity

WEG overload relays include phase failure sensitivity protection as standard. This feature ensures fast tripping in case of phase loss, protecting your motor and avoiding expensive repairs / corrective maintenance services.

Multi Function Button

The programmable RESET button can be selected to operate in a Manual or Automatic mode, with or without TEST capabilities of the isolated "trip" NC and "alarm" NO auxiliary contacts. The multifunction RESET / TEST button can be set in four different positions; H (manual RESET only), HAND (manual RESET/TEST), AUTO (automatic RESET/ TEST) and A (automatic RESET only). In HAND and AUTO positions, when RESET button is pushed, both NO (97-98) and NC (95-96) contacts change states.



Certifications



Overload Relays

- Thermal overload relays
- Phase-failure sensitivity according to IEC/EN 60 947-4-1, DIN VDE 0660 T. 102
- Tripping class 10
- Auxiliary contacts 1NO + 1NC
- Temperature compensation
- Hand/Auto/Reset button

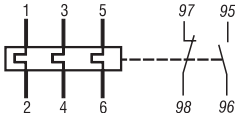
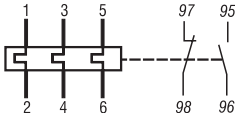
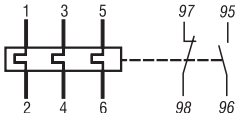
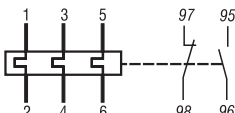
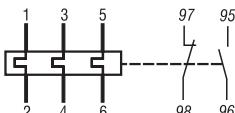
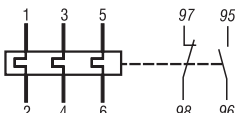
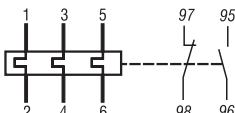
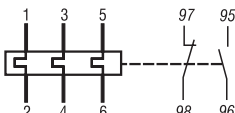

For use with	Setting range of overload release  Ir (A)	Circuit diagram	Fuse gL-gG ¹⁾ A	Reference Code	Weight kg
CWC07...16	0.28...0.4		2	RW17-1D3-D004	0.15
	0.4...0.63		2	RW17-1D3-C063	
	0.56...0.8		2	RW17-1D3-D008	
	0.8...1.2		4	RW17-1D3-D012	
	1.2...1.8		6	RW17-1D3-D018	
	1.8...2.8		6	RW17-1D3-D028	
	2.8...4.0		10	RW17-1D3-U004	
	4.0...6.3		16	RW17-1D3-D063	
	5.6...8.0		20	RW17-1D3-U008	
	7.0...10		25	RW17-1D3-U010	
	8.0...12.5		25	RW17-1D3-D125	
	10.0...15.0		35	RW17-1D3-U015	
11.0...17.0	35	RW17-1D3-U017			
CWC025	7...10		25	RW17-2D3-U010	0.15
	8...12.5		25	RW17-2D3-D125	
	10...15		35	RW17-2D3-U015	
	11...17		35	RW17-2D3-U017	
	15...23		50	RW17-2D3-U023	
	22...32		63	RW17-2D3-U032	
CWM9...CWM32	0.28...0.4		2	RW27-1D3-D004	0.147
	0.4...0.63		2	RW27-1D3-C063	
	0.56...0.8		2	RW27-1D3-D008	
	0.8...1.2		4	RW27-1D3-D012	
	1.2...1.8		6	RW27-1D3-D018	
	1.8...2.8		6	RW27-1D3-D028	
	2.8...4.0		10	RW27-1D3-U004	
	4.0...6.3		16	RW27-1D3-D063	
	5.6...8.0		20	RW27-1D3-U008	
	7.0...10		25	RW27-1D3-U010	
	8.0...12.5		25	RW27-1D3-D125	
	10...15		35	RW27-1D3-U015	
11...17	35	RW27-1D3-U017			
15...23	50	RW27-1D3-U023			
22...32	63	RW27-1D3-U032			
CWM32...CWM40	25...40		80	RW67-1D3-U040	0.300
	32...50		100	RW67-1D3-U050	
CWM50...CWM80	40...57		100	RW67-2D3-U057	0.310
	50...63		100	RW67-2D3-U063	
	57...70		125	RW67-2D3-U070	
CWM95...CWM105	63...80		125	RW67-2D3-U080	0.520
	75...97		200	RW117-1D3-U097	
CWM112	90...112		250	RW117-1D3-U112	0.550
	75...97		200	RW117-2D3-U097	
CWM150...CWM250	90...112		250	RW117-2D3-U112	2.3
	100...150		315	RW317-1D3-U150	
	140...215		355	RW317-1D3-U215	
	200...310		500	RW317-1D3-U310	

Note: 1) Type 2 Coordination

Overload Relays

- Thermal overload relays
- Phase-failure sensitivity according to IEC/EN 60 947-4-1, DIN VDE 0660 T. 102
- Tripping class 10
- Auxiliary contacts 1NO + 1NC
- Temperature compensation
- Hand/Auto/Reset button

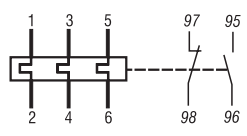

For use with	Setting range of overload release  I _r (A)	Circuit diagram	Fuse gL-gG ¹⁾ A	Reference Code	Weight kg
CWM300 CWME400	275...420		700	RW317-1D3-U420	2.3
CWME400...800	400...600 560...840		1000 1250	RW407-1D3-U600 RW407-1D3-U840	3.12

Overload Relays - Accessories

Mounting kit

Illustrative picture	Description	For use with	Reference Code	Weight kg
	Enables overload to be mounted directly to a panel via screws or DIN rail	RW17	A17	0.015
		RW27-1D	BF27D	0.050
		RW67-1D RW67-2D	BF67-1D BF67-2D	0.095
		RW117-1D	BF117D	0.110

Connector links for connection between CWM/CWME contactors and RW overload relays

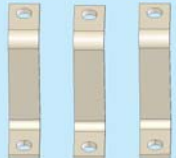
Illustrative picture	Overload relay	Contactors	Reference Code	Weight kg
	RW117-2D	CWM112	GA117D	0.135
	RW317	CWM150	GA317-1D	0.250
		CWM180	GA317-2D	0.270
		CWM250...300	GA317-3D	0.630
		CWME400	GA317-10D	0.500
	RW407	CWME630-800	JBL RW407D	1.580

Overload Relays - Technical Data

Reference Code	RW17	RW27	RW67	RW117	RW317	RW407
Standards	IEC/EN 60 947. DIN VDE 0660. UL. CSA			IEC/EN 60 947. DIN VDE 0660		
Setting current (A)	0.28...17	0.28...32	25...80	75...112	100...420	400...840
Tripping class	10					
Temperature compensation	continuous					
Rated insulation voltage U_i IEC/EN 60 947/DIN VDE 0660 (V) UL/CSA (V)	690			1000		
Rated impulse withstand voltage U_{imp} (kV)	6			8		
Rated operational frequency (Hz)	0...400					
Degree of protection Protection against direct contact from the front when actuated by a perpendicular test finger (IEC 536)	IP 20 finger and back-of-hand proof					
Ambient temperature Operating temperature Storage temperature	-25 °C to +60 °C -40 °C to +70 °C					
Climating proof IEC 60 068-2-3 IEC 60 068-2-30	Damp heat. constant Damp heat. constant					
Current heat loss Lower value of setting range (W) Higher value of setting range (W)	0.9 1.4	0.9 1.7	1.5 4.7	2.3 4.7	1 1.9	
Terminal capacity						
solid mm ²	2x 1.5 ... 6		1x 6 ...35	1x 25 ... 35	-	
flexible without cable lug mm ²	2x 1.5 ... 6		1x 6 ...35	1x 25 ... 35	-	
flexible with cable lug mm ²	2x 1.5 ... 6		1x 6 ...35	1x 25 ... 35	-	
stranded mm ²	2x 1.5 ...6		1x 6 ...35	1x 25 ... 35	-	
solid and stranded AWG	10		18 ... 2	8 ... 1/0	-	
bar mm	14 ... 6		-	-	20 x 4	
Tightening torque	1.4...2.3		4 ... 6	5...6.5	14...26	
Main circuit Nm	1...1.5		1...1.5	1...1.5	1...1.5	
Auxiliary and control circuits Nm						

Auxiliary contacts

Reference Code	RW17	RW27	RW67	RW117	RW317	RW407	
Rated insulation voltage U_i IEC/EN 60 947/DIN VDE 0660 (V) UL/CSA (V)				690 600			
Rated operational current I_o							
AC-15	120 V (A)				3		
	240 V (A)				2		
	415 V (A)				1.5		
	500 V (A)				0.5		
	UL/CSA			C600			
DC-13	24 VDC (A)				1		
	60 VDC (A)				0.5		
	110 VDC (A)				0.25		
	220 VDC (A)				0.1		
	UL/CSA			R300			

RW Tripping characteristics

These tripping characteristics show the tripping of RW in relation to the current. They show the mean values of the tolerance ranges at an ambient temperature of 20°C, starting from cold stats. The tripping time of the overload releases at operational temperature is reduced to approximately 25% of the values shown.

Under normal operational conditions, all three phases of the RWs should be loaded.

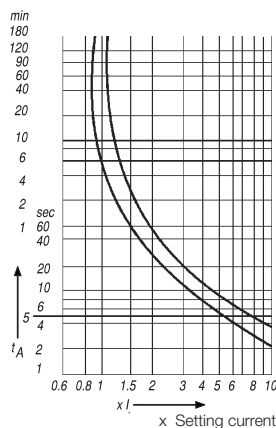

Overload Relays - Dimensions (mm)

RW17-1D

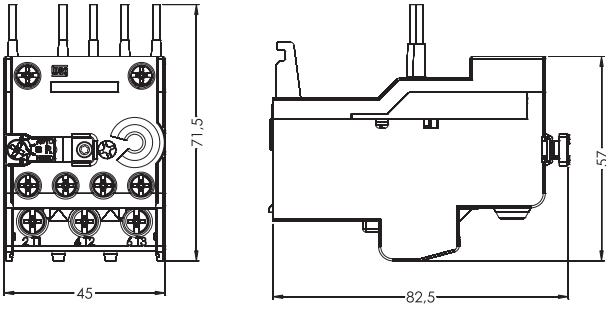

RW17-2D

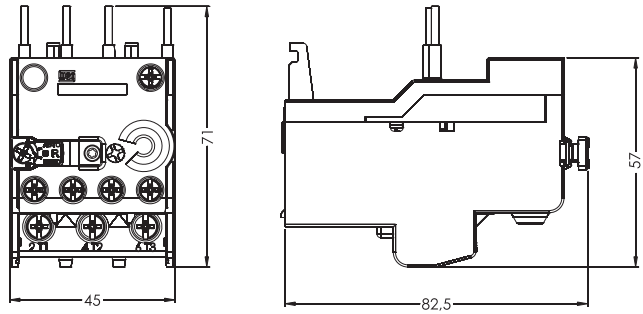

RW27

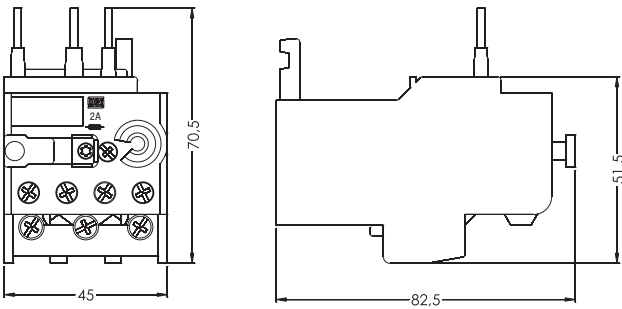

RW27 + BF27

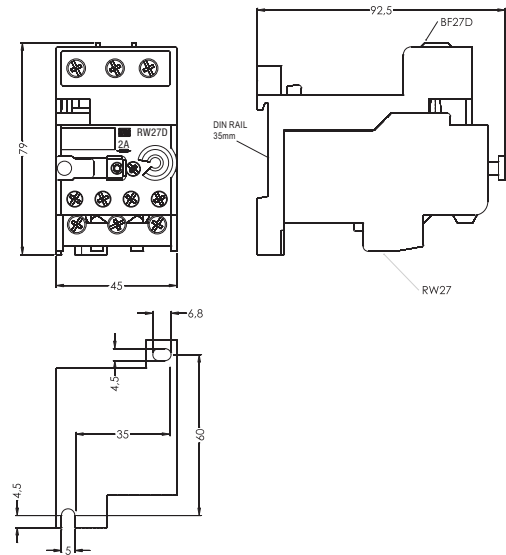

RW67

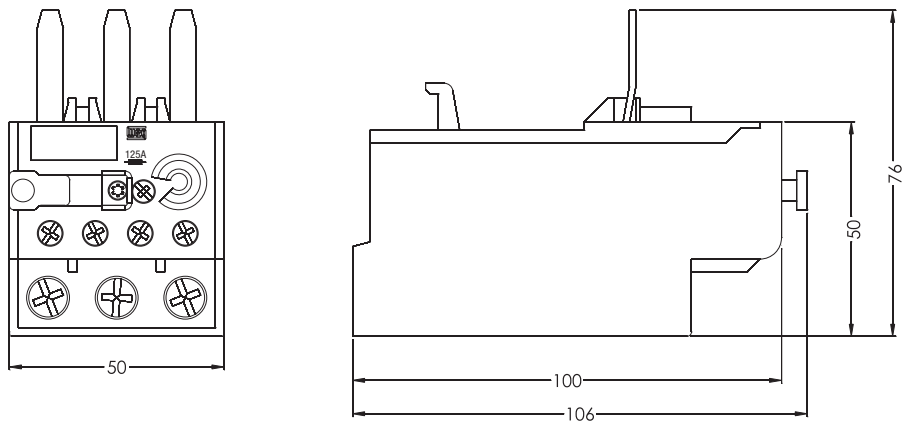

Overload Relays - Dimensions (mm)

RW67 + BF67

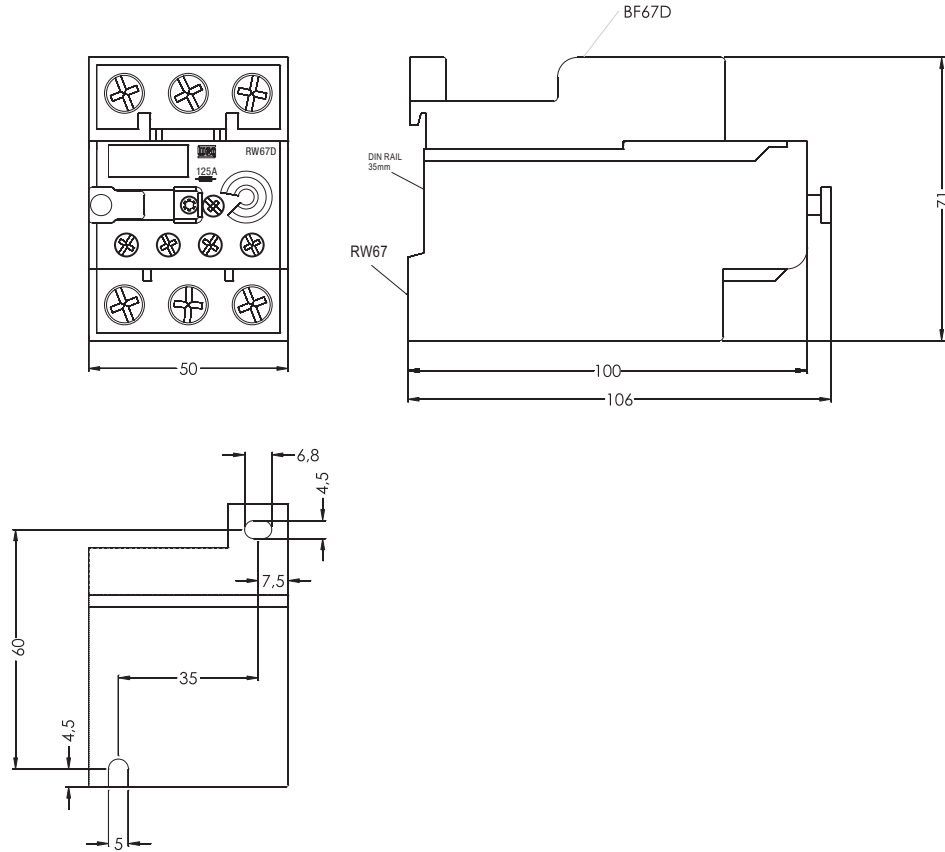

RW117-1D

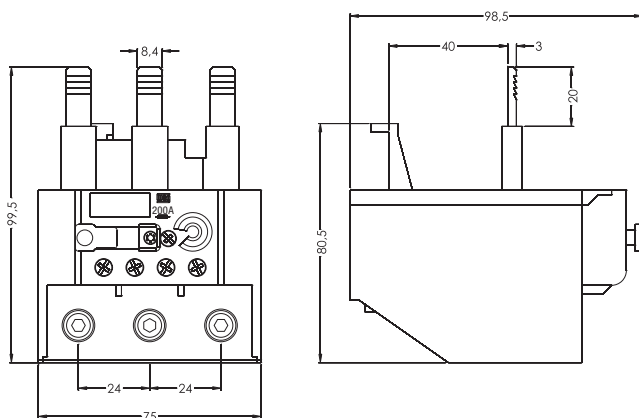

RW117-2D

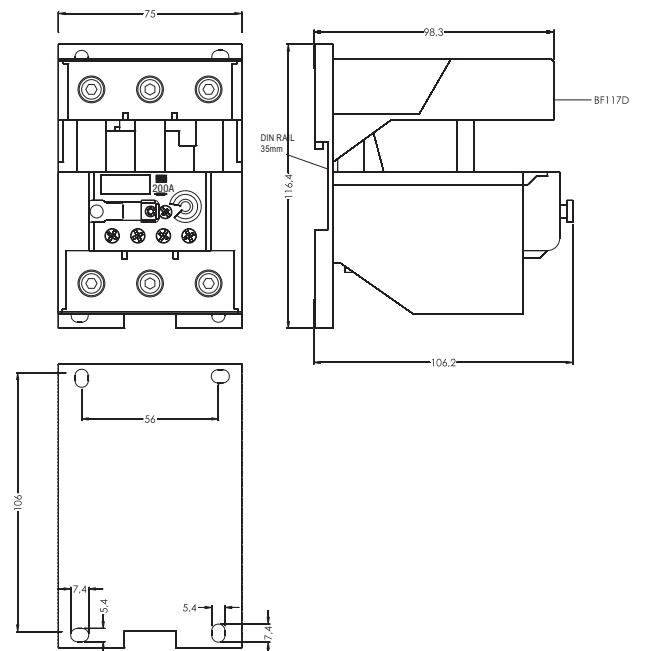

Overload Relays - Dimensions (mm)

RW317

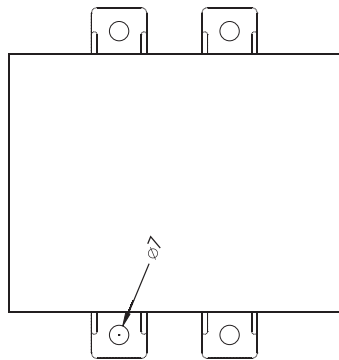
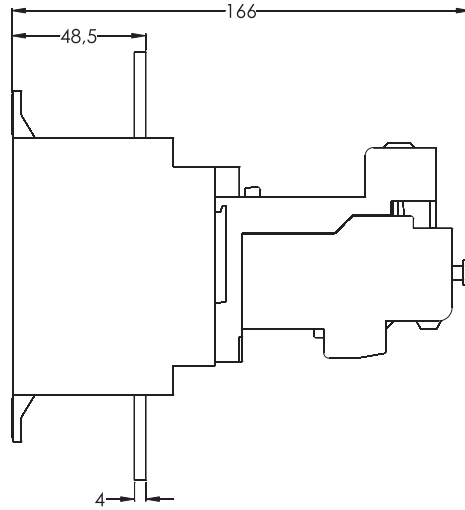
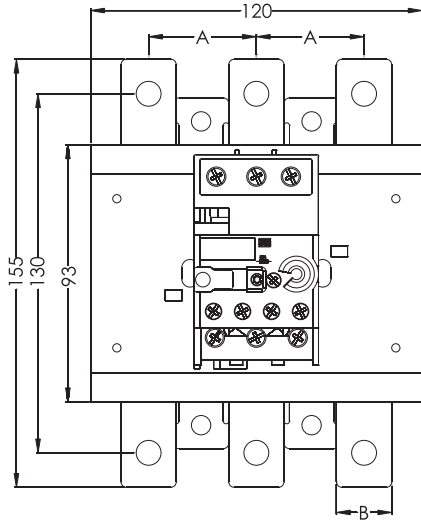

Current ranges	A	B
100...150A	39	20
140...215A		
200...310A	45	25
275...420A		

RW407

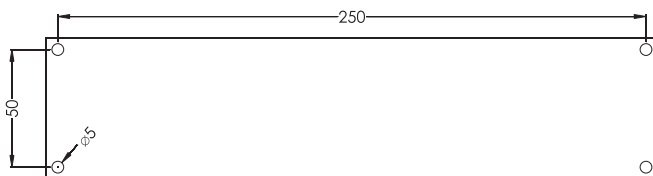
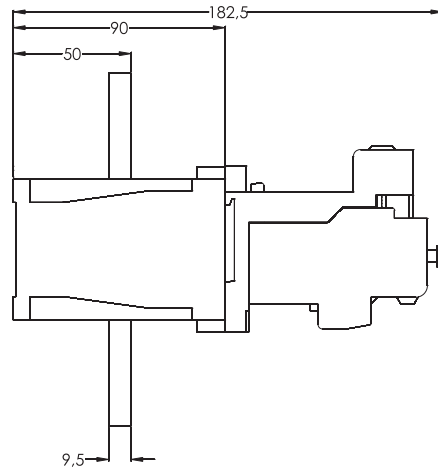
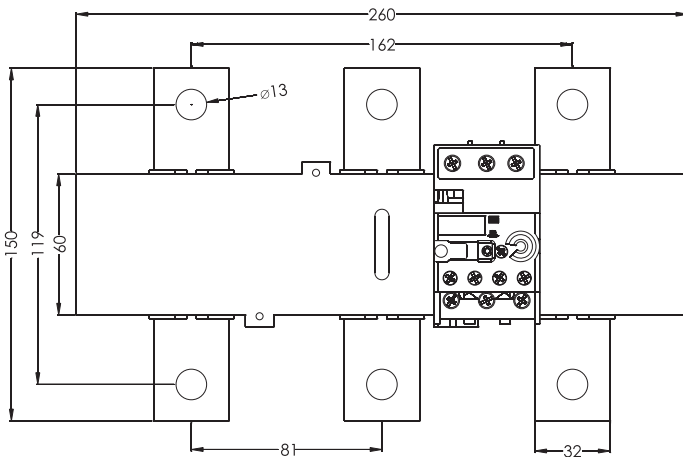

Contactors and Overload Relays - Dimensions (mm)

CWC07...16 + RW17-1D

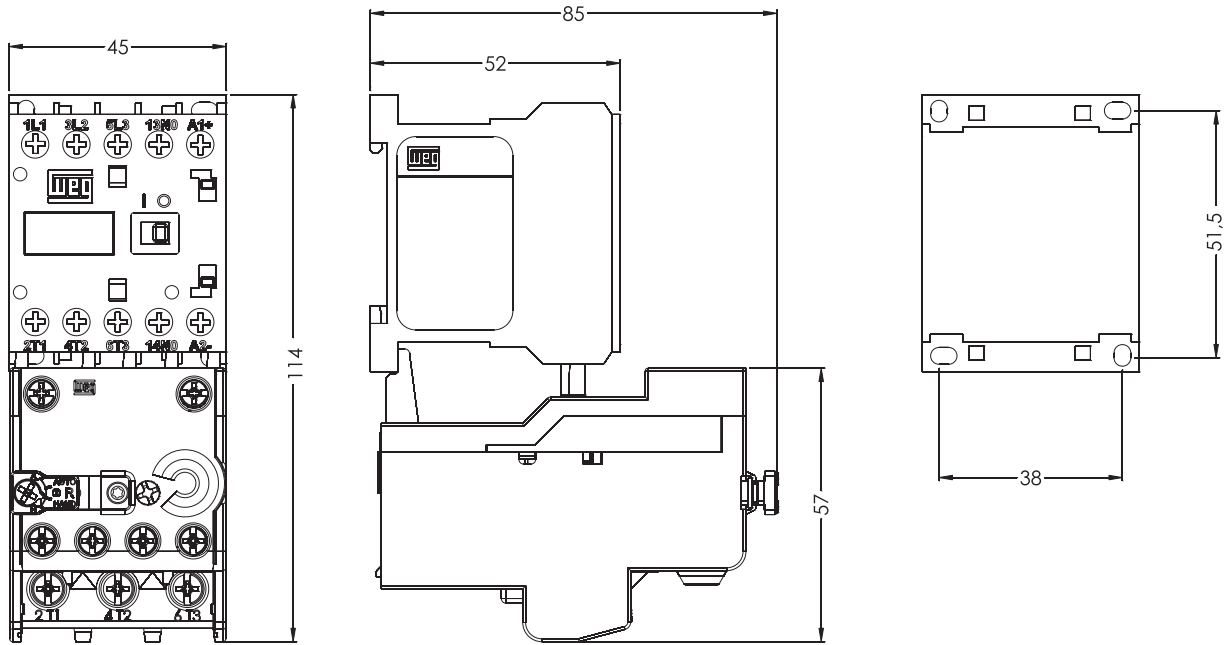

CWC025 + RW17-2D

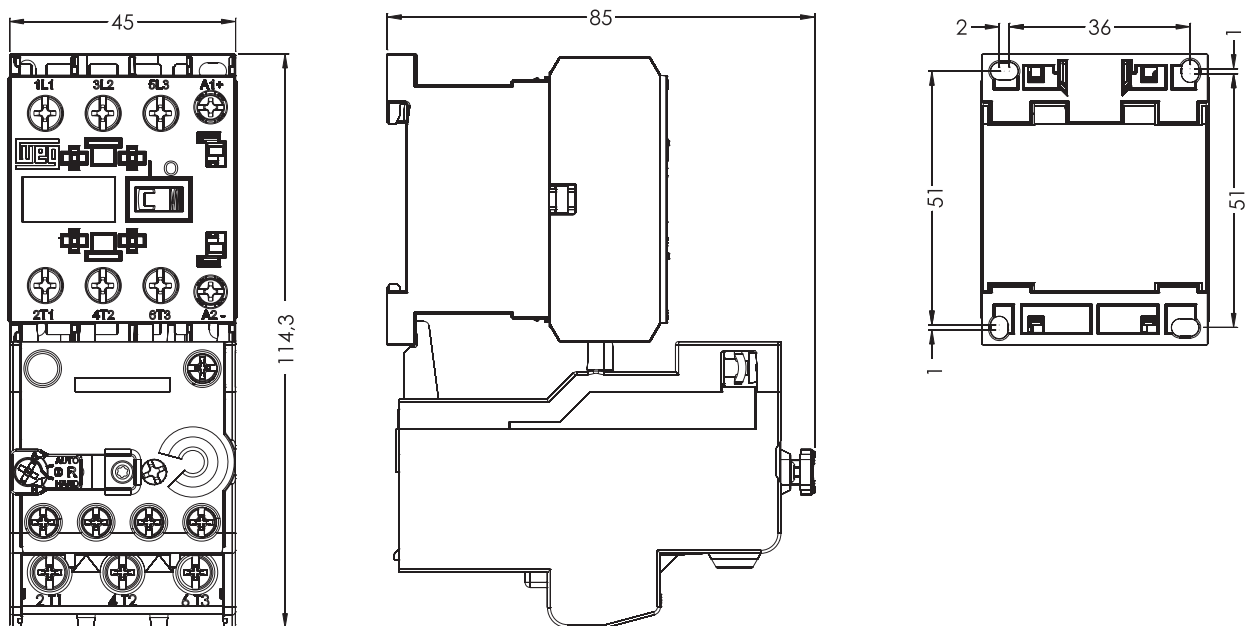

Contactors and Overload Relays - Dimensions (mm)

CWM9...25 + RW27

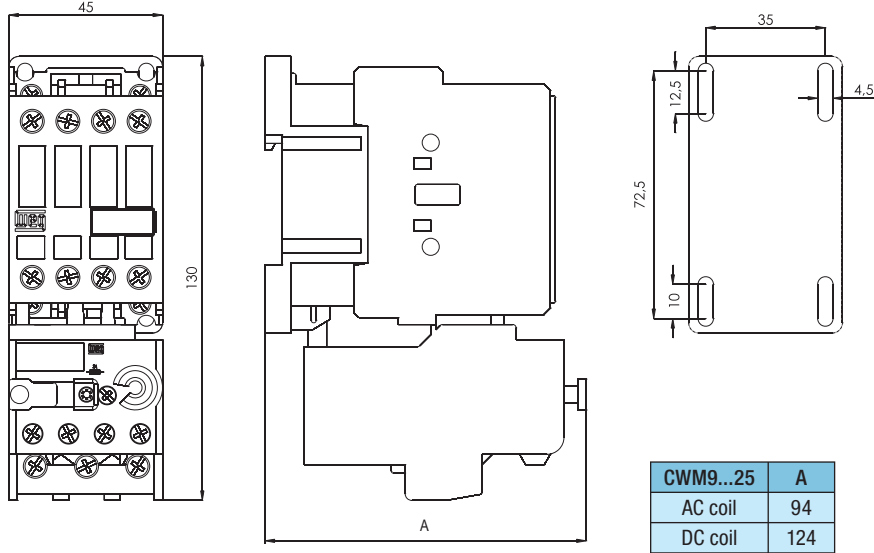

CWM32 + RW27

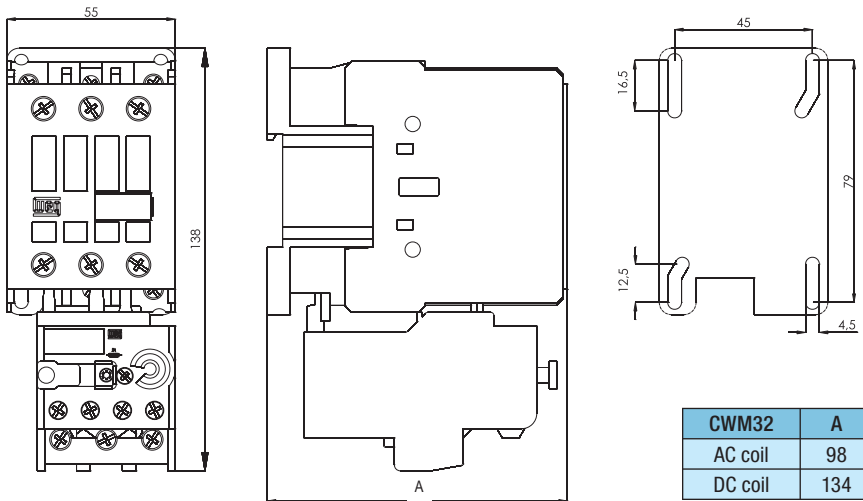

Contactors and Overload Relays - Dimensions (mm)

CWM32/40 + RW67-1D

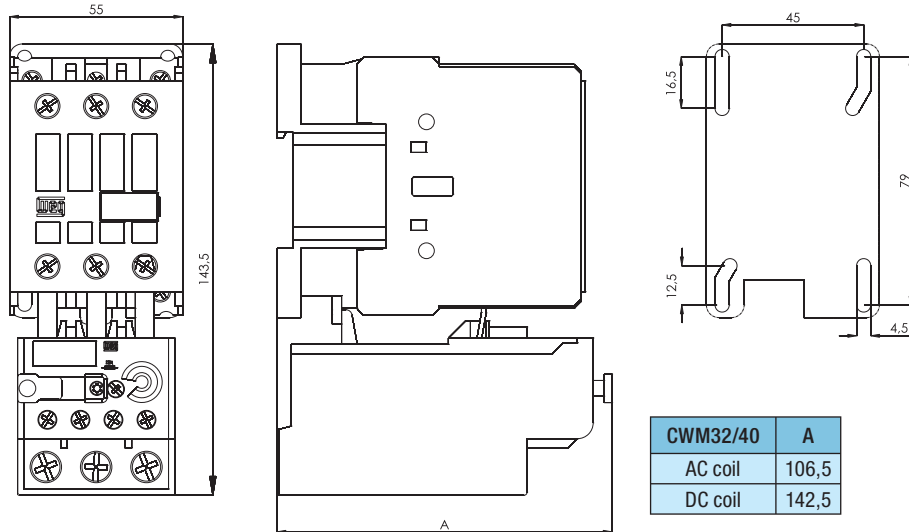

CWM50...80 + RW67-2D

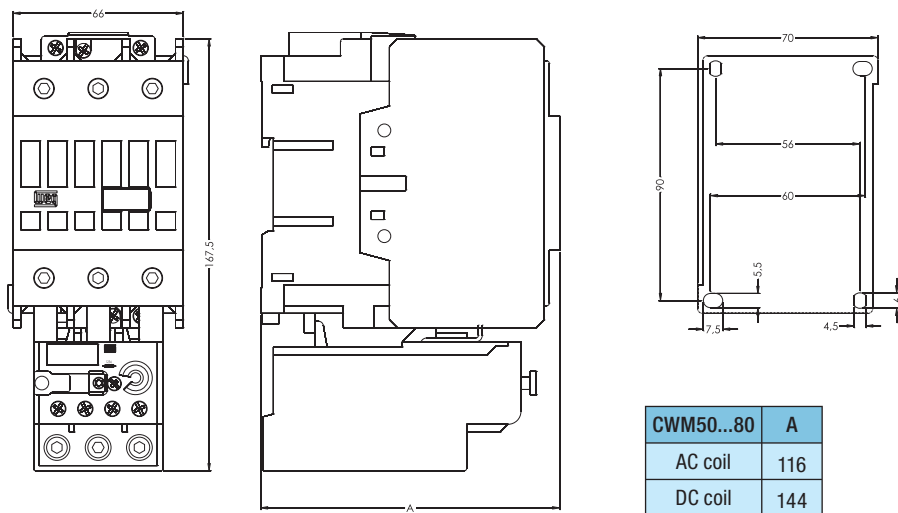

Contactors and Overload Relays - Dimensions (mm)

CWM95/105 + RW117-1D

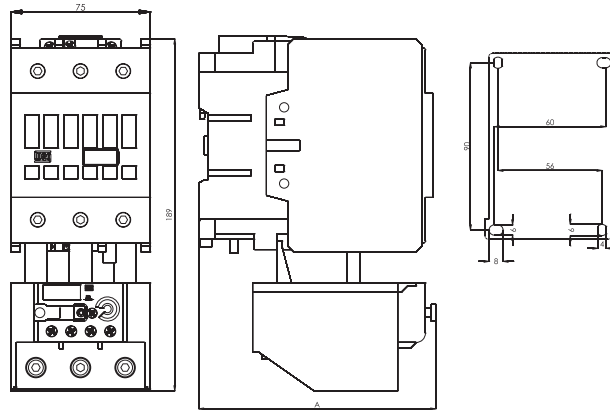

CWM95/105	A
AC coil	127,5
DC coil	155,5

CWM112 + RW117-2D

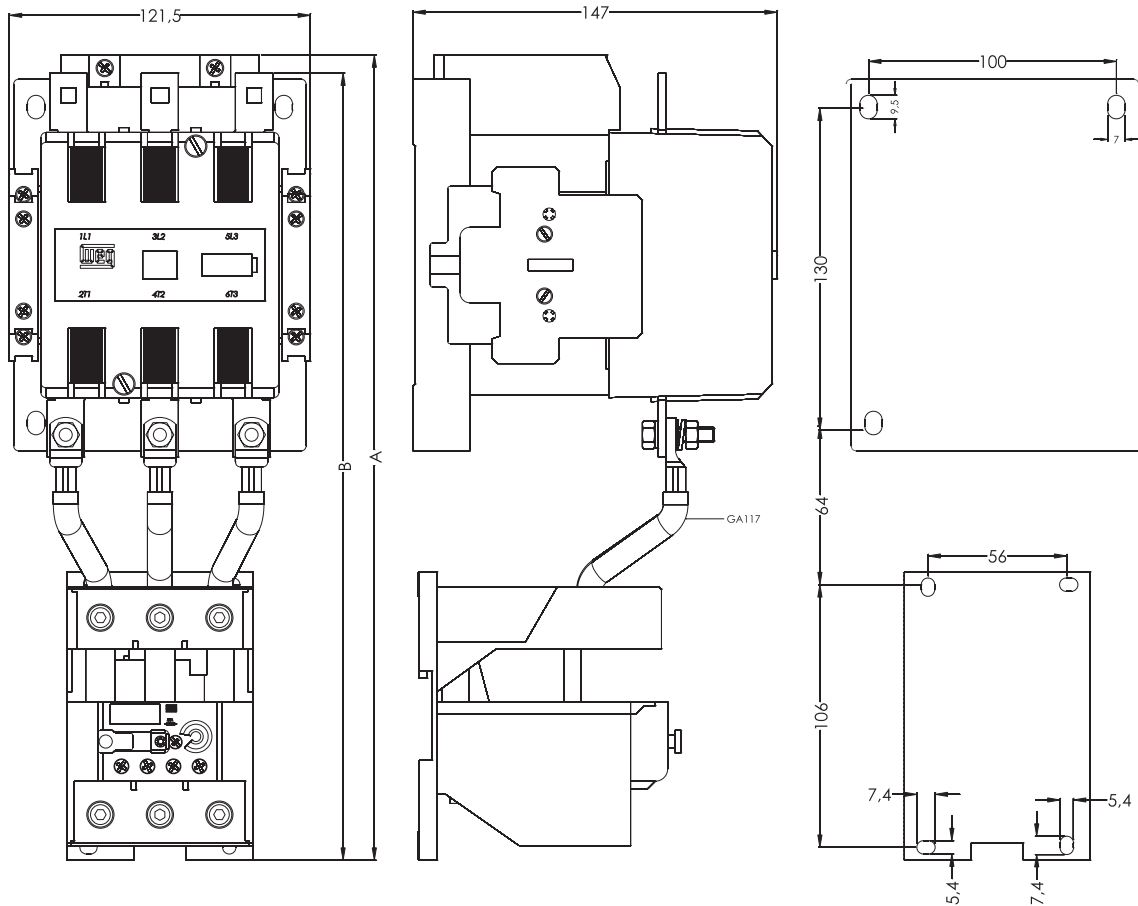

Contactors and Overload Relays - Dimensions (mm)

CWM180 + RW317

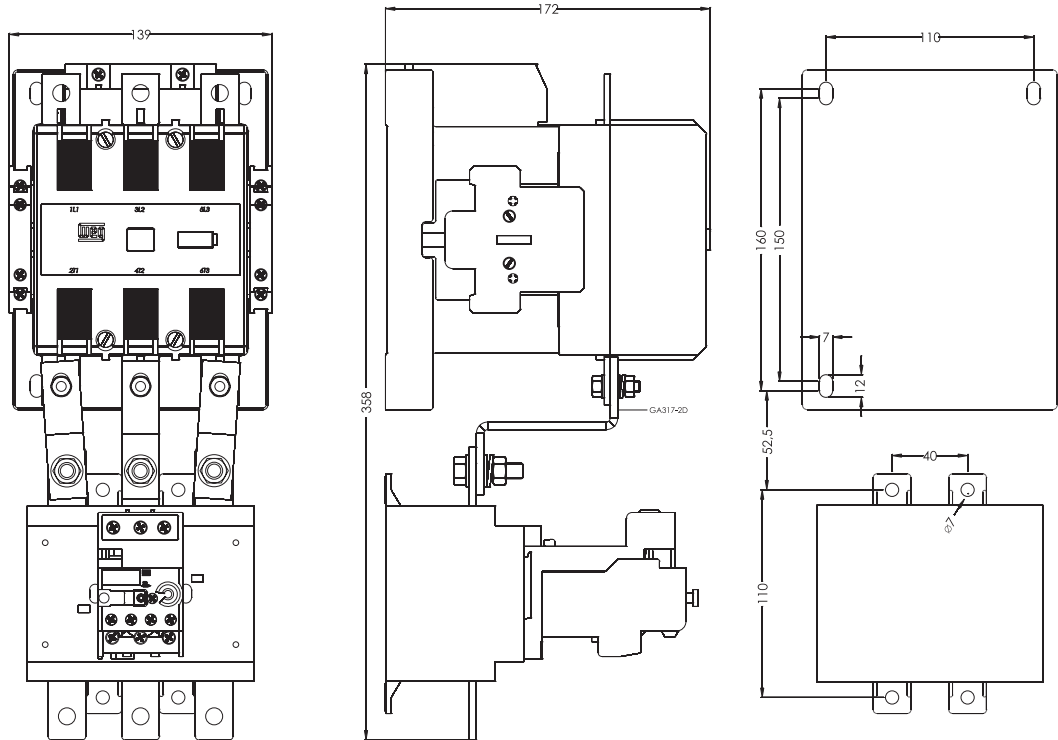

CWM250/300 + RW317

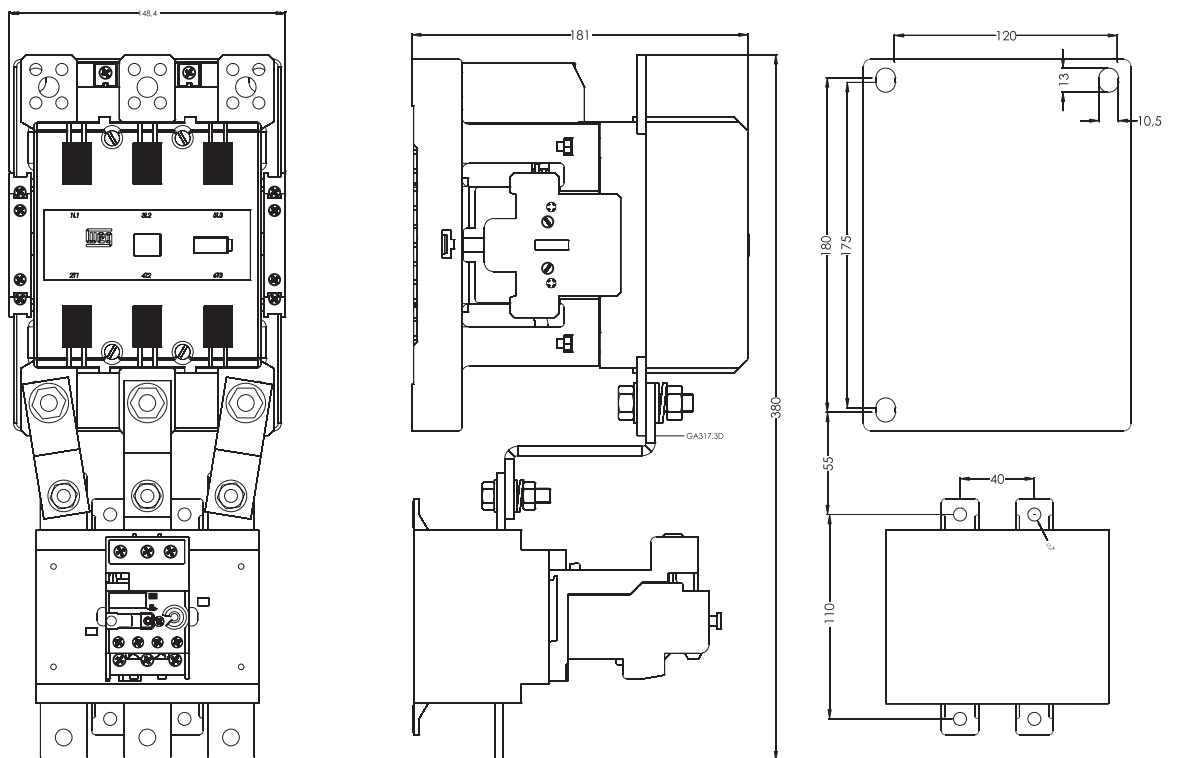

Motor Protective Circuit Breaker

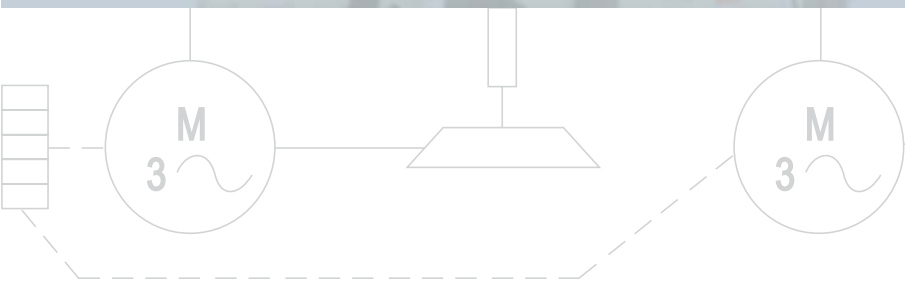
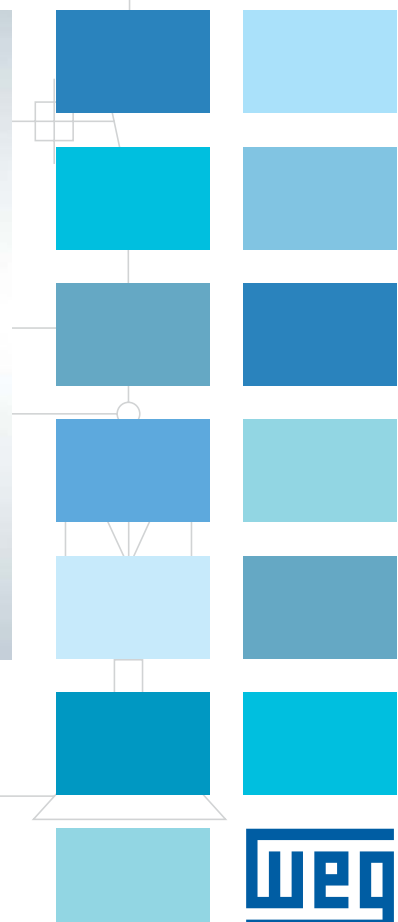
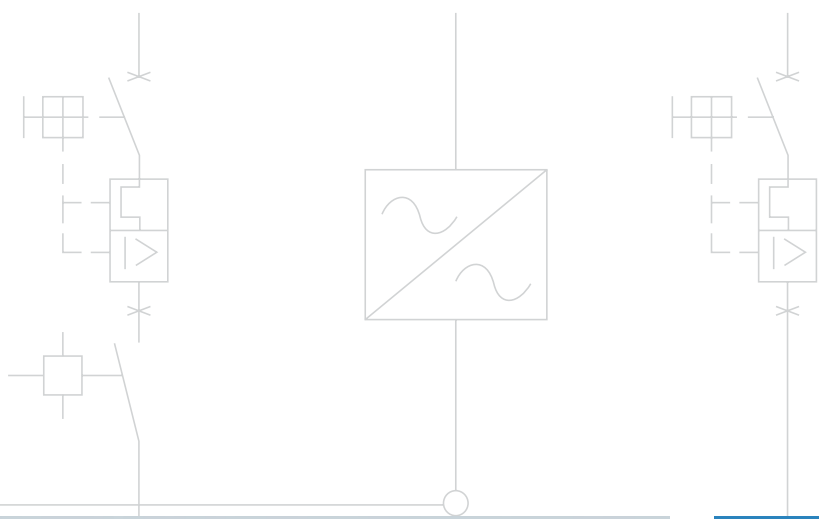

Operation and Protection of Motors up to 100A



Motor Protective Circuit Breakers MPW - Overview

With the latest technology and design, MPW series provide saving panel space and suitable to be used in most applications in motor control.



It combines short-circuit and motor overload protections in just one component. These devices include a three-position rotary ON-TRIP-OFF handle, which can be padlocked in the OFF position

		MPW16 up to 16A		MPW25 up to 32A			
							
General Technical Data	Maximum Rated Current $I_{max}(I_u)$	16A		32A			
	Number of poles	3		3			
	Short-Circuit release	13 x I_u max	13 x I_u max	13 x I_u max	13 x I_u max	19 x I_u max	
	Rated Operational Voltage U_e	690V	690V	690V	690V	690V	
	Rated Frequency	50/60Hz	50/60Hz	50/60Hz	50/60Hz	50/60Hz	
	Utilization category	IEC 60 947-2 (Circuit Breaker)	A	A	A	A	A
		IEC 60 947-4-1 (Motor starter)	AC-3	AC-3	AC-3	AC-3	AC-3
	Tripping Test	Yes	Yes	Yes	Yes	Yes	
	Overload Protection	Yes	No	Yes	No	Yes	
	Phase failure sensitivity	Yes	No	Yes	No	Yes	
	Tripping Indication	Yes	Yes	Yes	Yes	Yes	
	Tripping Class	10	-	10	-	10	
	Mechanical life	Number of operations	100,000	100,000	100,000	100,000	100,000
	Electrical life	Number of operations	100,000	100,000	100,000	100,000	100,000
	Temperature compensation		-20...+60°C	-	-20...+60°C	-	-20...+60°C
Type of protection		Thermomagnetic	Magnetic	Thermomagnetic	Magnetic	Thermomagnetic	
Setting overload release  $I_r(A)$		Reference code		Reference code			
0.1...0.16		MPW16-3-C016	MPW16i-3-C016	MPW25-3-C016	MPW25i-3-C016	MPW25t-3-C016	
0.16...0.25		MPW16-3-C025	MPW16i-3-C025	MPW25-3-C025	MPW25i-3-C025	MPW25t-3-C025	
0.25...0.4		MPW16-3-D004	MPW16i-3-D004	MPW25-3-D004	MPW25i-3-D004	MPW25t-3-D004	
0.4...0.63		MPW16-3-C063	MPW16i-3-C063	MPW25-3-C063	MPW25i-3-C063	MPW25t-3-C063	
0.63...1		MPW16-3-U001	MPW16i-3-U001	MPW25-3-U001	MPW25i-3-U001	MPW25t-3-U001	
1...1.6		MPW16-3-D016	MPW16i-3-D016	MPW25-3-D016	MPW25i-3-D016	MPW25t-3-D016	
1.6...2.5		MPW16-3-D025	MPW16i-3-D025	MPW25-3-D025	MPW25i-3-D025	MPW25t-3-D025	
2.5...4		MPW16-3-U004	MPW16i-3-U004	MPW25-3-U004	MPW25i-3-U004	MPW25t-3-U004	
4...6.3		MPW16-3-D063	MPW16i-3-D063	MPW25-3-D063	MPW25i-3-D063	MPW25t-3-D063	
6.3...10		MPW16-3-U010	MPW16i-3-U010	MPW25-3-U010	MPW25i-3-U010	MPW25t-3-U010	
10...16		MPW16-3-U016	MPW16i-3-U016	MPW25-3-U016	MPW25i-3-U016	MPW25t-3-U016	
16...20				MPW25-3-U020	MPW25i-3-U020	MPW25t-3-U020	
20...25				MPW25-3-U025	MPW25i-3-U025	MPW25t-3-U025	
25...32				MPW25-3-U032	MPW25i-3-U032	MPW25t-3-U032	
32...40							
40...50							
50...65							
55...75							
70...90							
80...100							

Motor Protective Circuit Breakers MPW - Overview

Designed for DIN rail mounting, while lugs for direct panel mounting are also available as accessory.

MPW Motor Protective Circuit Breakers are available in four models: MPW16/MPW25 (45mm), MPW65 (54mm) and MPW100 (70mm) and designed for use according to international standards, making them suitable for applications all over the world.

		MPW65 up to 65A		MPW100 up to 100A	
					
General Technical Data	Maximum Rated Current $I_{max}(I_u)$	65A		100A	
	Number of poles	3		3	
	Short-Circuit release	13 x I_u max	13 x I_u max	13 x I_u max	
	Rated Operational Voltage U_e	690V	690V	690V	
	Rated Frequency	50/60Hz	50/60Hz	50/60Hz	
	Use category	IEC 60 947-2 (Circuit Breaker)	A	A	A
		IEC 60 947-4-1 (Motor starter)	AC-3	AC-3	AC-3
	Tripping Test	Yes	Yes	Yes	
	Overload Protection	Yes	No	Yes	
	Phase failure sensitivity	Yes	No	Yes	
	Tripping Indication	Yes	Yes	Yes	
	Tripping Class	10	-	10	
	Mechanical life	Number of operations	50,000	50,000	50,000
	Electrical life	Number of operations	25,000	25,000	25,000
	Temperature compensation		-20...+60°C	-	-20...+60°C
Type of protection		Thermomagnetic	Magnetic	Thermomagnetic	
Setting overload release  $I_r(A)$		Reference code		Reference code	
0.1...0.16		-	-	-	
0.16...0.25					
0.25...0.4					
0.4...0.63					
0.63...1					
1...1.6					
1.6...2.5					
2.5...4					
4...6.3					
6.3...10					
10...16		MPW65-3-U016	MPW65i-3-U016	-	
16...20		MPW65-3-U020	MPW65i-3-U020		
20...25		MPW65-3-U025	MPW65i-3-U025		
25...32		MPW65-3-U032	MPW65i-3-U032		
32...40		MPW65-3-U040	MPW65i-3-U040		
40...50		MPW65-3-U050	MPW65i-3-U050		
50...65		MPW65-3-U065	MPW65i-3-U065		
55...75		-	-		MPW100-3-U075
70...90					MPW100-3-U090
80...100					MPW100-3-U100

Motor Protective Circuit Breaker MPW16 - Overview

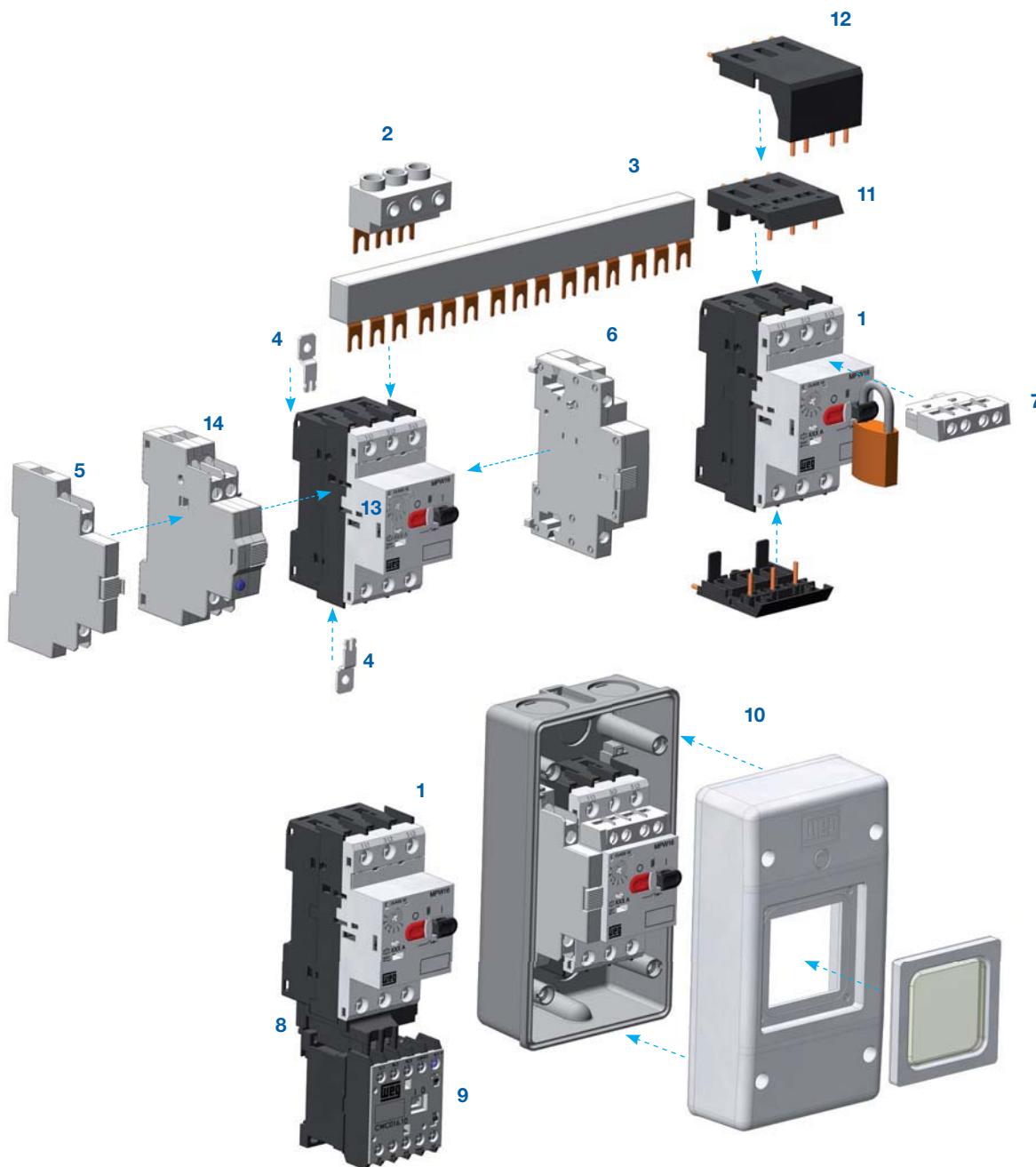

- 1 - Motor protective circuit breaker MPW16
- 2 - Feeder terminal FTBBS
- 3 - Three-phase commoning block BBS
- 4 - Push-in-lugs PLMP
- 5 - Side auxiliary contact block ACBS
- 6 - Undervoltage release URMP or shunt release SRMP
- 7 - Front auxiliary contact block ACBF
- 8 - Connector ECCMP-C016 (MPW16 + CWC07...16)
- 9 - Mini contactor CWC07...16
- 10 - Insulated enclosure
- 11 - Block module for power terminals to printed circuit board
- 12 - Block module for auxiliary frontal contact block to printed circuit board
- 13 - Scale cover SCMP

Motor Protective Circuit Breaker MPW16 - Selection Table

- With overload and short circuit protection
- Fixed short circuit release $13 \times I_n$
- With phase-failure sensivity according to IEC/EN 60947-4-1/DIN VDE 0660 T.102
- With temperature compensation
- For use as main switch
- MPW16 up to 6,3 A at 400/415 V are self protected
- MPW16 fulfill UL/CSA



Motor Protective Circuit Breaker MPW16 - Thermomagnetic

Reference table for selecting protection of three-phase motor 50/60Hz - 4 poles ¹⁾						Rated Current I_n (A)	Setting Overload Release I_r (A)	Instantaneous Magnetic Trip I_m (A)	Reference Code	Weight kg
220-240V hp / kW	380-415V hp / kW	440-480V hp / kW	500V hp / kW	550-600V hp / kW	690V hp / kW					
-	-	-	-	-	-	0.16	0.1...0.16	2.0	MPW16-3-C016	0.28
-	-	-	-	-	0.16 / 0.12	0.25	0.16...0.25	3.2	MPW16-3-C025	
-	-	0.16 / 0.12	0.16 / 0.12	0.16 / 0.12	0.25 / 0.18	0.4	0.25...0.4	5.2	MPW16-3-D004	
-	0.16 / 0.12	0.25 / 0.18	0.25 / 0.18	0.33 / 0.25	0.33 / 0.25	0.63	0.4...0.63	8.1	MPW16-3-C063	
0.16 / 0.12	0.33 / 0.25	0.33 / 0.25	0.5 / 0.37	0.5 / 0.37	0.75 / 0.55	1	0.63...1	13	MPW16-3-U001	
0.33 / 0.25	0.5 / 0.37	1 / 0.75	1 / 0.75	1 / 0.75	1.5 / 1.1	1.6	1...1.6	20.8	MPW16-3-D016	
0.5 / 0.37	1 / 0.75	1.5 / 1.1	1.5 / 1.1	1.5 / 1.1	2 / 1.5	2.5	1.6...2.5	32.5	MPW16-3-D025	
1 / 0.75	2 / 1.5	2 / 1.5	2 / 1.5	3 / 2.2	4 / 3	4	2.5...4	52	MPW16-3-U004	
1.5 / 1.1	3 / 2.2	4 / 3	4 / 3	5 / 3.7	5.5 / 4	6.3	4...6.3	81.9	MPW16-3-D063	
3 / 2.2	6 / 4.5	7.5 / 5.5	5.5 / 4	7.5 / 5.5	10 / 7.5	10	6.3...10	130	MPW16-3-U010	
5 / 3.7	10 / 7.5	12.5 / 9.2	12.5 / 9.2	15 / 11	15 / 11	16	10...16	208	MPW16-3-U016	

Motor Protective Circuit Breaker MPW16i - Magnetic

Reference table for selecting protection of three-phase motor 50/60Hz - 4 poles ¹⁾						Rated current I_n (A)	Instantaneous Magnetic Trip I_m (A)	Reference Code	Weight kg
220-240V hp / kW	380-415V hp / kW	440-480V hp / kW	500V hp / kW	550-600V hp / kW	690V hp / kW				
-	-	-	-	-	-	0.16	2.0	MPW16i-3-C016	0.28
-	-	-	-	-	0.16 / 0.12	0.25	3.2	MPW16i-3-C025	
-	-	0.16 / 0.12	0.16 / 0.12	0.16 / 0.12	0.25 / 0.18	0.4	5.2	MPW16i-3-D004	
-	0.16 / 0.12	0.25 / 0.18	0.25 / 0.18	0.33 / 0.25	0.33 / 0.25	0.63	8.1	MPW16i-3-C063	
0.16 / 0.12	0.33 / 0.25	0.33 / 0.25	0.5 / 0.37	0.5 / 0.37	0.75 / 0.55	1	13	MPW16i-3-U001	
0.33 / 0.25	0.5 / 0.37	1 / 0.75	1 / 0.75	1 / 0.75	1.5 / 1.1	1.6	20.8	MPW16i-3-D016	
0.5 / 0.37	1 / 0.75	1.5 / 1.1	1.5 / 1.1	1.5 / 1.1	2 / 1.5	2.5	32.5	MPW16i-3-D025	
1 / 0.75	2 / 1.5	2 / 1.5	2 / 1.5	3 / 2.2	4 / 3	4	52	MPW16i-3-U004	
1.5 / 1.1	3 / 2.2	4 / 3	4 / 3	5 / 3.7	5.5 / 4	6.3	81.9	MPW16i-3-D063	
3 / 2.2	6 / 4.5	7.5 / 5.5	5.5 / 4	7.5 / 5.5	10 / 7.5	10	130	MPW16i-3-U010	
5 / 3.7	10 / 7.5	12.5 / 9.2	12.5 / 9.2	15 / 11	15 / 11	16	208	MPW16i-3-U016	

Note: 1) Some motors characteristics may vary according to each manufacture

Motor Protective Circuit Breaker MPW25 - Overview

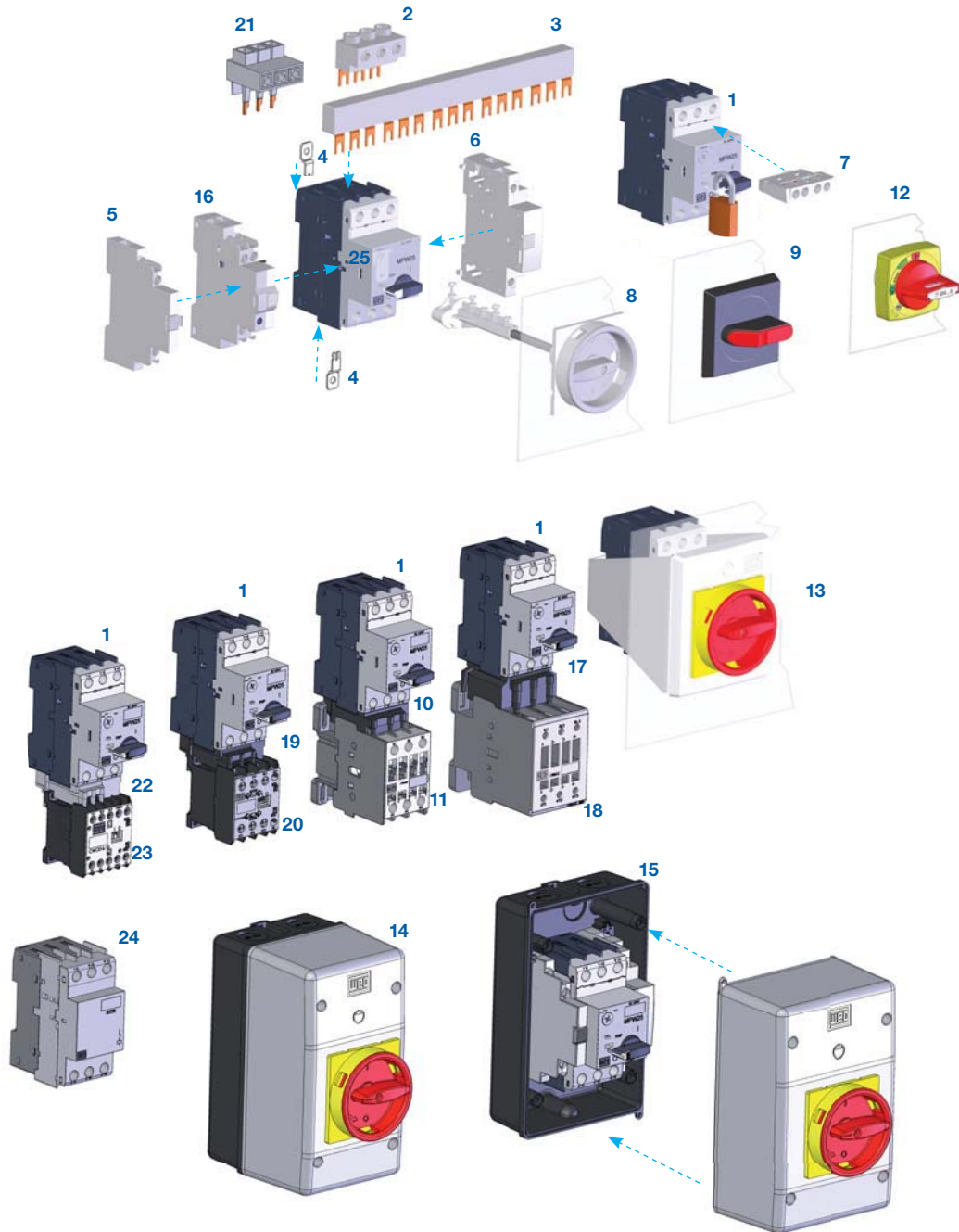

- | | |
|---|---|
| <ul style="list-style-type: none"> 1 - Motor protective circuit breaker MPW25 2 - Feeder terminal FTBBS 3 - Three-phase commoning block BBS 4 - Push-in-lugs PLMP 5 - Side auxiliary contact block ACBS 6 - Undervoltage release URMP or shunt release SRMP 7 - Front auxiliary contact block ACBF 8 - Door coupling rotary handle RMMP 9 - Panel door rotary handle MR MPW25 10 - Conector ECCMP-25 (MPW25 + CWM9...25) 11 - Contactors CWM9...25 12 - Door coupling rotary handle MRX 13 - Front plate FME55 | <ul style="list-style-type: none"> 14 - Standard insulated enclosure MPE55 15 - Large insulated enclosure MLPE55 16 - Trip signalling block TSB 17 - Conector ECCMP-32 (MPW25 + CWM32...40) 18 - Contactors CWM32...40 19 - Conector ECCMP-C025 (MPW25 + CWC025) 20 - Mini contactor CWC025 21 - Feeder terminal for "Type E" motor starter according to UL LST25 22 - Conector ECCMP-C0 (MPW25 + CWC07...16) 23 - Mini contactor CWC07...16 24 - Current limiter CLT25 25 - Scale cover SCMP |
|---|---|

Motor Protective Circuit Breaker MPW25 - Selection Table

- With overload and short circuit protection
- Fixed short circuit release $13 \times I_n$
- With phase-failure sensitivity according to IEC/EN 60947-4-1/DIN VDE 0660 T.102
- With temperature compensation
- For use as main switch
- MPW25 up to 10 A at 400/415 V are self protected
- MPW25 fulfill UL/CSA



Motor Protective Circuit Breaker MPW25 - Thermomagnetic

Reference table for selecting protection of three-phase motor 50/60Hz - 4 poles ¹⁾						Rated Current I_n (A)	Setting Overload Release I_r (A)	Instantaneous Magnetic Trip I_m (A)	Reference Code	Weight kg
220-240V hp / kW	380-415V hp / kW	440-480V hp / kW	500V hp / kW	550-600V hp / kW	690V hp / kW					
-	-	-	-	-	-	0.16	0.1...0.16	2.0	MPW25-3-C016	0.36
-	-	-	-	-	0.16 / 0.12	0.25	0.16...0.25	3.2	MPW25-3-C025	
-	-	0.16 / 0.12	0.16 / 0.12	0.16 / 0.12	0.25 / 0.18	0.4	0.25...0.4	5.2	MPW25-3-D004	
-	0.16 / 0.12	0.25 / 0.18	0.25 / 0.18	0.33 / 0.25	0.33 / 0.25	0.63	0.4...0.63	8.1	MPW25-3-C063	
0.16 / 0.12	0.33 / 0.25	0.33 / 0.25	0.5 / 0.37	0.5 / 0.37	0.75 / 0.55	1	0.63...1	13	MPW25-3-U001	
0.33 / 0.25	0.5 / 0.37	1 / 0.75	1 / 0.75	1 / 0.75	1.5 / 1.1	1.6	1...1.6	20.8	MPW25-3-D016	
0.5 / 0.37	1 / 0.75	1.5 / 1.1	1.5 / 1.1	1.5 / 1.1	2 / 1.5	2.5	1.6...2.5	32.5	MPW25-3-D025	
1 / 0.75	2 / 1.5	2 / 1.5	2 / 1.5	3 / 2.2	4 / 3	4	2.5...4	52	MPW25-3-U004	
1.5 / 1.1	3 / 2.2	4 / 3	4 / 3	5 / 3.7	5.5 / 4	6.3	4...6.3	81.9	MPW25-3-D063	
3 / 2.2	6 / 4.5	7.5 / 5.5	5.5 / 4	7.5 / 5.5	10 / 7.5	10	6.3...10	130	MPW25-3-U010	
5 / 3.7	10 / 7.5	12.5 / 9.2	12.5 / 9.2	15 / 11	15 / 11	16	10...16	208	MPW25-3-U016	
7.5 / 5.5	12.5 / 9.2	15 / 11	15 / 11	-	20 / 15	20	16...20	260	MPW25-3-U020	
-	15 / 11	-	20 / 15	20 / 15	25 / 18.5	25	20...25	325	MPW25-3-U025	
12.5 / 9.2	20 / 15	20 / 15	25 / 18.5	30 / 22	30 / 22	32	25...32	416	MPW25-3-U032	

Motor Protective Circuit Breaker MPW25i - Magnetic

Reference table for selecting protection of three-phase motor 50/60Hz - 4 poles ¹⁾						Rated Current I_n (A)	Instantaneous Magnetic Trip I_m (A)	Reference Code	Weight kg
220-240V hp / kW	380-415V hp / kW	440-480V hp / kW	500V hp / kW	550-600V hp / kW	690V hp / kW				
-	-	-	-	-	-	0.16	2.0	MPW25i-3-C016	0.36
-	-	-	-	-	0.16 / 0.12	0.25	3.2	MPW25i-3-C025	
-	-	0.16 / 0.12	0.16 / 0.12	0.16 / 0.12	0.25 / 0.18	0.4	5.2	MPW25i-3-D004	
-	0.16 / 0.12	0.25 / 0.18	0.25 / 0.18	0.33 / 0.25	0.33 / 0.25	0.63	8.1	MPW25i-3-C063	
0.16 / 0.12	0.33 / 0.25	0.33 / 0.25	0.5 / 0.37	0.5 / 0.37	0.75 / 0.55	1	13	MPW25i-3-U001	
0.33 / 0.25	0.5 / 0.37	1 / 0.75	1 / 0.75	1 / 0.75	1.5 / 1.1	1.6	20.8	MPW25i-3-D016	
0.5 / 0.37	1 / 0.75	1.5 / 1.1	1.5 / 1.1	1.5 / 1.1	2 / 1.5	2.5	32.5	MPW25i-3-D025	
1 / 0.75	2 / 1.5	2 / 1.5	2 / 1.5	3 / 2.2	4 / 3	4	52	MPW25i-3-U004	
1.5 / 1.1	3 / 2.2	4 / 3	4 / 3	5 / 3.7	5.5 / 4	6.3	81.9	MPW25i-3-D063	
3 / 2.2	6 / 4.5	7.5 / 5.5	5.5 / 4	7.5 / 5.5	10 / 7.5	10	130	MPW25i-3-U010	
5 / 3.7	10 / 7.5	12.5 / 9.2	12.5 / 9.2	15 / 11	15 / 11	16	208	MPW25i-3-U016	
7.5 / 5.5	12.5 / 9.2	15 / 11	15 / 11	-	20 / 15	20	260	MPW25i-3-U020	
-	15 / 11	-	20 / 15	20 / 15	25 / 18.5	25	325	MPW25i-3-U025	
12.5 / 9.2	20 / 15	20 / 15	25 / 18.5	30 / 22	30 / 22	32	416	MPW25i-3-U032	

Note: 1) Some motors characteristics may vary according to each manufacture

Motor Protective Circuit Breaker MPW65 – Overview

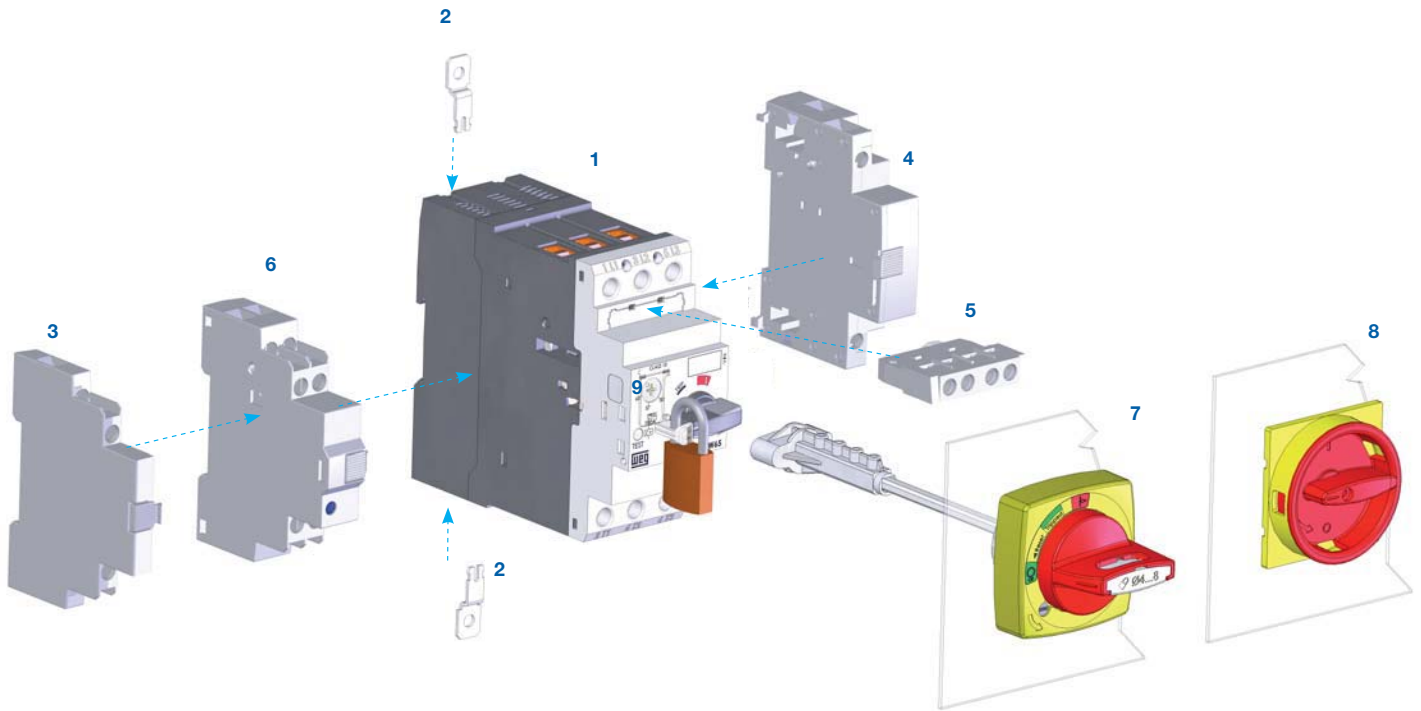

- 1 - Motor protective circuit breaker MPW65
- 2 - Push-in-lugs PLMP
- 3 - Side auxiliary contact block ACBS
- 4 - Undervoltage release URMP or shunt release SRMP
- 5 - Frontal auxiliary contact block ACBF
- 6 - Trip signalling block TSB
- 7 - Door coupling rotary handle MRX65
- 8 - Door coupling rotary handle RMMP65
- 9 - Scale cover SCMP

Motor Protective Circuit Breaker MPW65 - Selection Table

- With overload and short circuit protection
- Fixed short circuit release $13 \times I_n$
- With phase-failure sensitivity according to IEC/EN 60947-4-1/DIN VDE 0660 T.102
- With temperature compensation
- For use as main switch
- MPW65 above 65 A provide a breaking capacity of 50 kA at 400/415 V according to IEC/EN 60947-2
- MPW65 fulfill UL/CSA



Motor Protective Circuit Breaker MPW65 - Thermomagnetic

Reference table for selecting protection of three-phase motor 50/60Hz - 4 poles ¹⁾						Rated Current I_n (A)	Setting Overload Release I_r (A)	Instantaneous Magnetic Trip I_m (A)	Reference Code	Weight kg
220-240V hp / kW	380-415V hp / kW	440-480V hp / kW	500V hp / kW	550-600V hp / kW	690V hp / kW					
5 / 3.7	10 / 7.5	12.5 / 9.2	12.5 / 9.2	15 / 11	15 / 11	16	10...16	208	MPW65-3-U016	1.07
7.5 / 5.5	12.5 / 9.2	15 / 11	15 / 11	-	20 / 15	20	16...20	260	MPW65-3-U020	
-	15 / 11	-	20 / 15	20 / 15	25 / 18.5	25	20...25	325	MPW65-3-U025	
12.5 / 9.2	20 / 15	20 / 15	25 / 18.5	30 / 22	30 / 22	32	25...32	416	MPW65-3-U032	
15 / 11	25 / 18.5	30 / 22	30 / 22	-	50 / 37	40	32...40	520	MPW65-3-U040	
-	30 / 22	40 / 30	40 / 30	50 / 37	60 / 45	50	40...50	650	MPW65-3-U050	
25 / 18.5	40 / 30	50 / 37	60 / 45	60 / 45	75 / 55	65	50...65	845	MPW65-3-U065	

Motor Protective Circuit Breaker MPW65i - Magnetic

Reference table for selecting protection of three-phase motor 50/60Hz - 4 poles ¹⁾						Rated Current I_n (A)	Instantaneous Magnetic Trip I_m (A)	Reference Code	Weight kg
220-240V hp / kW	380-415V hp / kW	440-480V hp / kW	500V hp / kW	550-600V hp / kW	690V hp / kW				
5 / 3.7	10 / 7.5	12.5 / 9.2	12.5 / 9.2	15 / 11	15 / 11	16	208	MPW65i-3-U016	1.07
7.5 / 5.5	12.5 / 9.2	15 / 11	15 / 11	-	20 / 15	20	260	MPW65i-3-U020	
-	15 / 11	-	20 / 15	20 / 15	25 / 18.5	25	325	MPW65i-3-U025	
12.5 / 9.2	20 / 15	20 / 15	25 / 18.5	30 / 22	30 / 22	32	416	MPW65i-3-U032	
15 / 11	25 / 18.5	30 / 22	30 / 22	-	50 / 37	40	520	MPW65i-3-U040	
-	30 / 22	40 / 30	40 / 30	50 / 37	60 / 45	50	650	MPW65i-3-U050	
25 / 18.5	40 / 30	50 / 37	60 / 45	60 / 45	75 / 55	65	845	MPW65i-3-U065	

Motor Protective Circuit Breaker MPW100 - Selection Table

- With overload and short circuit protection
- Fixed short circuit release $13 \times I_n$
- With phase-failure sensitivity according to IEC/EN 60947-4-1/DIN VDE 0660 T.102
- With temperature compensation
- For use as main switch
- MPW100 up to 100 A at 400/415 V are self protected
- MPW100 above 100 A provide a breaking capacity of 50 kA (Icu) at 400/415 V according to IEC/EN 60947-2
- MPW100 fulfill UL/CSA



Motor Protective Circuit Breaker MPW100 - Thermomagnetic

Reference table for selecting protection of three-phase motor 50/60Hz - 4 poles ¹⁾						Rated Current I_n (A)	Setting Overload Release I_r (A)	Instantaneous Magnetic Trip I_m (A)	Reference Code	Weight kg
230V hp / kW	400V hp / kW	460V hp / kW	500V hp / kW	575V hp / kW	690V hp / kW					
25 / 18.5	50 / 37	60 / 45	60/45	75 / 55	75 / 55	75	55...75	975	MPW100-3-U075	2.2
30 / 22	60 / 45	75 / 55	75/55	75 / 55	100 / 75	90	70...90	1170	MPW100-3-U090	
40 / 30	60 / 45	75 / 55	75/55	75 / 55	125 / 90	100	80...100	1300	MPW100-3-U100	

Note: 1) Some motors characteristics may vary according to each manufacture

Motor Protective Circuit Breaker MPW25t - Selection Table

Motor Protective Circuit Breaker for protection of transformers or motors with high starting current

- With overload and short circuit protection
- Fixed short circuit release $19 \times I_u$
- With phase-failure sensivity according to IEC/EN 60947-4-1/DIN VDE 0660 T.102
- With temperature compensation
- For use as main switch



Reference table for selecting protection of three-phase motor 50/60Hz - 4 poles ¹⁾					Rated Current I_u (A)	Setting Overload Release I_r (A)	Instantaneous Magnetic Trip I_{tm} (A)	Short-Circuit Breaking capacity 400/415VAC I_{cu} (kA)	Reference Code	Weight kg
220-240V hp / kW	380-415V hp / kW	440-480V hp / kW	500V hp / kW	690V hp / kW						
-	-	-	-	-	0.16	0.1...0.16	3	100	MPW25t-3-C016	0.36
-	-	-	-	0.16 / 0.12	0.25	0.16...0.25	4.8	100	MPW25t-3-C025	
-	-	0.16 / 0.12	0.16 / 0.12	0.25 / 0.18	0.4	0.25...0.4	7.6	100	MPW25t-3-D004	
-	0.16 / 0.12	0.25 / 0.18	0.25 / 0.18	0.33 / 0.25	0.63	0.4...0.63	12	100	MPW25t-3-C063	
0.16 / 0.12	0.33 / 0.25	0.33 / 0.25	0.5 / 0.37	0.75 / 0.55	1	0.63...1	19	100	MPW25t-3-U001	
0.33 / 0.25	0.5 / 0.37	1 / 0.75	1 / 0.75	1.5 / 1.1	1.6	1...1.6	30.4	100	MPW25t-3-D016	
0.5 / 0.37	1 / 0.75	1.5 / 1.1	1.5 / 1.1	2 / 1.5	2.5	1.6...2.5	47.5	100	MPW25t-3-D025	
1 / 0.75	2 / 1.5	2 / 1.5	2 / 1.5	4 / 3	4	2.5...4	76	100	MPW25t-3-U004	
1.5 / 1.1	3 / 2.2	4 / 3	4 / 3	5.5 / 4	6.3	4...6.3	119.7	100	MPW25t-3-D063	
3 / 2.2	6 / 4.5	7.5 / 5.5	5.5 / 4	10 / 7.5	10	6.3...10	190	100	MPW25t-3-U010	
5 / 3.7	10 / 7.5	12.5 / 9.2	12.5 / 9.2	15 / 11	16	10...16	304	50	MPW25t-3-U016	
7.5 / 5.5	12.5 / 9.2	15 / 11	15 / 11	20 / 15	20	16...20	380	50	MPW25t-3-U020	

Applications of the motor protective circuit breaker MPW25t for the protection of transformers:

When control of transformers are protected on their primary winding, the high in-rush current caused by starting of the transformer normally cause unwanted trip of the protection devices.

Due to this fact, circuit breakers of the MPW25t series are designed with overcurrent release set to approximately 19 times the rated operational current, allowing the breakers to be used for the protection of transformers.

Tripping Characteristics:

The tripping characteristic shows the motor circuit breaker trip time in relation to the rated current.

The curves show average tolerance range values for an ambient temperature of 20°C, starting in cold state. Thermal trip time when working in operating temperature is reduced to around 25% of the presented values. Under normal operating conditions, all 3 circuit breaker phases must be conducting.

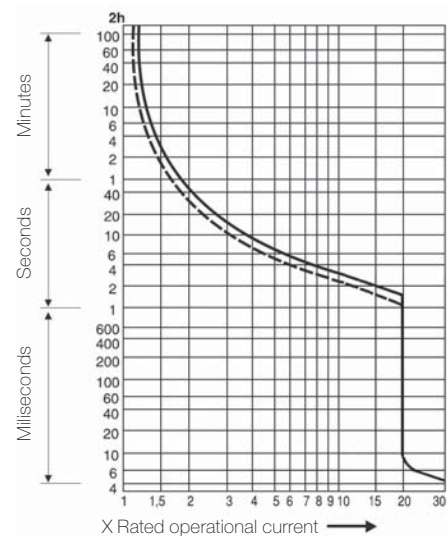

Note: 1) Some motors characteristics may vary according to each manufacture

Motor Protective Circuit Breakers MPW - Accessories

Front Auxiliary Contact Block - ACBF

For use with	Illustrative picture	Auxiliary Contacts		Reference Code	Weight kg
		NO	NC		
MPW16/16i. MPW25/25i/25t. MPW65/65i 1)		1	1	ACBF-11	0.024
MPW100				ACBF-11 MPW100	0.018

Left side auxiliary contact block - ACBS

For use with	Illustrative picture	Auxiliary Contacts		Reference Code	Weight kg
		NO	NC		
MPW16/16i. MPW25/25i/25t. MPW65/65i 1)		1	1	ACBS-11	0.045
		2	-	ACBS-20	
		-	2	ACBS-02	
MPW100		1	1	ACBS-11 MPW100	0.030
		2	-	ACBS-20 MPW100	
		-	2	ACBS-02 MPW100	

Note: 1) The following accessories can be assembled at the same time: 1 ACBF + 1 URMP/SRMP + 1 TSB or 1 ACBS + 1 URMP/SRMP + 1 TSB

Motor Protective Circuit Breakers MPW - Accessories

Trip Signalling Block - TSB

For use with	Illustrative picture	Description	Reference Code	Weight kg
MPW25/25i/25t, MPW65/65i ¹⁾		<ul style="list-style-type: none"> - Equipped with 2 auxiliary contacts (1NO + 1NC) for overload trip signalling and 2 other auxiliary contacts (1NO + 1NC) for short-circuit trip signalling. - To reset the circuit breaker after a short-circuit, the flag must be manually reset after the cause of the failure has been solved. - Lateral auxiliary contacts can be assembled together with the trip signalling block. - Left side assembly only 	TSB	0,130
MPW100		<ul style="list-style-type: none"> - Equipped with 2 auxiliary contacts (1NO + 1NC) for overload and short-circuit trip signalling. - Left side assembly only 	TSB AT11 MPW100	0,040

Undervoltage Release - URMP

For use with	Illustrative picture	Voltage	Reference Code	Weight kg
MPW16/16i MPW25/25i/25t MPW65/65i ¹⁾		220V 60Hz 208V 60Hz 95V 50Hz / 110V 60Hz 24V 50/60Hz 110-115V 50Hz / 127V 60Hz 230-240V 50Hz / 277V 60Hz 380V 50Hz / 440V 60Hz 400-415V 50Hz / 480V 60Hz 500V 50Hz / 600V 60Hz 110V 50Hz / 120V 60Hz 240V 60Hz 220V 50Hz / 255V 60Hz 380V 60Hz 220V 50/60Hz	URMP V25 URMP V83 URMP V15 URMP D02 URMP V19 URMP V37 URMP V42 URMP V30 URMP V56 URMP V18 URMP V29 URMP V32 URMP V40 URMP D23	0,130
MPW100		Note: - Operating voltage > 0,85 x Ue - Non operating voltage 0,35...0,7 x Ue	110V 50Hz / 120V 60Hz 220-230V 50Hz / 240-260V 60Hz 380-400V 50Hz / 440-460V 60Hz	URMP V18 MPW100 URMP V33 MPW100 URMP V43 MPW100

Note: 1) The following accessories can be coupled at the same time: 1 ACBF + 1 URMP/SRMP + 1 TSB or 1 ACBS + 1 URMP/SRMP + 1 TSB

Motor Protective Circuit Breakers MPW - Accessories

Shunt Release - SRMP



For use with	Illustrative picture	Voltage	Reference Code	Weight kg
MPW16/16i MPW25/25i/25t. MPW65/65i 1)		20-24V 50/60Hz 40-48V 50/60Hz 100-127V 50/60Hz 200-240V 50/60Hz 365-440V 50/60Hz	SRMP D51 SRMP D54 SRMP D59 SRMP D65 SRMP D69	0.130
MPW100	Note: - Operating voltage > 0.7 x Ue	110V 50Hz / 120V 60Hz 220-230V 50Hz / 240-260V 60Hz 380-400V 50Hz / 440-460V 60Hz	SRMP V18 MPW100 SRMP V33 MPW100 SRMP V43 MPW100	0.040

Note: 1) The following accessories can be coupled at the same time: 1 ACBF + 1 URMP/SRMP + 1 TSB or 1 ACBS + 1 URMP/SRMP + 1 TSB

Insulators for UL - IB

For use with	Illustrative picture	Description	Reference Code	Weight kg
MPW100		Insulators for increasing creepage distance and clearances according to UL requirements.	IB MPW100	0.010

Block modules for motor protective circuit breaker assembly + contactors – ECCMP, C2075 and C20100

For use with	Illustrative picture	Description	Contactors	Reference Code	Weight kg
MPW16/16i		- For direct connection (electrical and mechanical) of motor circuit breakers to contactors. Note: - Not applicable to CWM contactors with DC coils.	CWC07...16	ECCMP-C016	0.025
MPW25/25i/25t			CWC07...16 CWC025 CWM9...25 CWM32...40	ECCMP-C0 ECCMP-C025 ECCMP-25 ECCMP-32	
MPW16/16i MPW25/25i/25t		Width: 45mm Rated current: 20A Length: 75mm	CWC07...16 CWM9...25	C2075	0.025
				C20100	

Motor Protective Circuit Breakers MPW - Accessories

Door Coupling Rotary Handle - RMMP and MR

For use with	Illustrative picture	Description	Handle color	Reference Code	Weight kg	
MPW25/25i/25t		<ul style="list-style-type: none"> - Degree of protection IP55; - Shows circuit breaker position "I"(ON) or "0"(OFF); - Panel door can only be opened in OFF position; - Adjustable shaft length. There are 2 standard shaft sizes: 130-155mm (Model 130) and 330-355mm (Model 330). To assembled the handle on the circuit breaker the shaft must have a length of at least 80mm; - Up to 3 padlocks can be used in the OFF position. This blocks circuit breaker operation and opens panel door; - Handle can be mounted on panels with a thickness of 1 to 5mm; - Handle can be assembled even with circuit breaker turned in 90° position 	Black	RMMP-130	0,250	
MPW65/65i			Red/ Yellow	RMMP-330		
			Red/ Yellow	RMMP-130E		
MPW65/65i			Red/ Yellow	RMMP-330E		
			Black	RMMP65-130		
MPW65/65i			Black	RMMP65-330		
	Red/ Yellow	RMMP65-130E				
MPW25/25i/25t		<ul style="list-style-type: none"> - Panel door can be opened in ON position (thermometry) - Degree of protection: MRX = IP65/Nema 4X - Shows circuit breaker position "I"(ON) or "0"(OFF) - Adjustable shaft length. There are 2 standard shaft sizes: 130-155mm (Model 130) and 330-355mm (Model 330). To assembled the handle ON the circuit breaker the shaft must have a length of at least 80mm - Up to 3 padlocks can be used in the OFF position. This blocks circuit breaker operation and opens panel door Handle can be mounted on panels with a thickness of 1 to 5mm 	Black	-		
			Black	-		
MPW65/65i			Black	MRX-130		
			Red/ Yellow	MRX-330		
MPW65/65i			Red/ Yellow	MRX-130E		
			Red/ Yellow	MRX-330E		
MPW65/65i			Black	MRX65-130		
			Black	MRX65-330		
MPW65/65i			Red/ Yellow	MRX65-130E		
			Red/ Yellow	MRX65-330E		
MPW100				<ul style="list-style-type: none"> - Degree of protection: IP65 - Shows circuit breaker position "I"(ON) or "0"(OFF); Adjustable shaft length. There are 2 standard shaft sizes: 220-282mm (Model 115) and 220-482mm (Model 315). Up to 3 padlocks can be used in the OFF position. This blocks circuit breaker operation and opens panel door 	Gray	MR MPW100-115
					Gray	MR MPW100-315

Standard Insulated Enclosure - MPE

For use with	Illustrative picture	Description	Terminals	Handle color	Reference Code	Weight kg
MPW16/16i		<ul style="list-style-type: none"> - Degree of protection: IP41 - Two M25 metric cable entry knockouts, top and bottom - Allows installing: MPW16 + ACBF11/PL lamps + ACBS 	With ground terminals	-	MPE41G	0,510
			With neutral and ground terminals		MPE41GN	
	MPW16/16i		<ul style="list-style-type: none"> - Degree of protection: IP66 - Two M25 metric cable entry knockouts, top and bottom - Allows installing: MPW16 + ACBF11/PL lamps + ACBS 	With ground terminals	-	MPE66G
With neutral and ground terminals				MPE66GN		
		<ul style="list-style-type: none"> - Enable to increase degree of protection from MPE41 (IP41) to IP66 	-	-	KITIP66	0,010
MPW25/25i/25t		<ul style="list-style-type: none"> - Degree of protection: IP55 - For use on emergency-stop switches to IEC/EN 60204 - Allows installing: MPW25 + ACBF11/PL lamps + ACBS - Two M25 metric cable entry knockouts, top and bottom - Handle can be locked with up to 3 padlocks at OFF position. 	With ground terminals	Black	MPE55G	0,510
				Red with yellow background	MPE55GE	0,510
			With neutral and ground terminals	Black	MPE55GN	0,420
				Red with yellow background	MPE55GNE	0,420

Motor Protective Circuit Breakers MPW - Accessories

Large Insulated Enclosure - MLPE55

For use with	Illustrative picture	Description	Terminals	Handle color	Reference Code	Weight kg
MPW25/25i/25t		<ul style="list-style-type: none"> - Degree of protection: IP55 - For use on emergency-stop switches to IEC/EN 60204 - For use with MPW25 + URMP/SRMP + ACBF11 + ACBS + PL lamps - Two M25 metric cable entry knockouts, top and bottom - Handle can be locked with up to 3 padlocks at OFF position. 	With ground terminals	Black	MLPE55G	0.54
				Red with yellow background	MLPE55G-E	0.54
			With neutral and ground terminals	Black	MLPE55GN	0.45
				Red with yellow background	MLPE55GN-E	0.45

Front Plate - FME55

For use with	Illustrative picture	Description	Handle color	Reference Code	Weight kg
MPW25/25i/25t		<ul style="list-style-type: none"> - For motor protective circuit breaker assembly in panel door or side; - Degree of protection: IP55; - MPW25 fits directly into base. - Rotary handle in enclosure fits directly into MPW25 handle; - Handle can be locked with up to 3 padlocks at OFF position; - Enables accessory installation: ACBF11 + ACBS + URMP/SRMP - PL signalling lamps can be installed on enclosure (without ACBF-11). 	Black	FME55	0.2
			Red with yellow background	FME55E	0.2

Motor Protective Circuit Breakers MPW - Accessories

Pilot Light - PL



For use with	Illustrative picture	Lamp color	Voltage	Reference Code	Weight kg
All models		Red	24V 50/60Hz / VDC	PL24-E26	0.005
			110...130V 50/60Hz	PL130-D61	
			210...230V 50/60Hz	PL230-D78	
			400...560V 50/60Hz	PL560-D79	
		Green	24V 50/60Hz /VDC	PL24G-E26	
			110...130V 50/60Hz	PL130G-D61	
			210...230V 50/60Hz	PL130G-D78	
			400...560V 50/60Hz	PL560G-D79	
		White	24V 50/60Hz / VDC	PL24W-E26	
			110...130V 50/60Hz	PL130W-D61	
			210...230V 50/60Hz	PL130W-D78	
			400...560V 50/60Hz	PL560W-D79	

Motor protective circuit breaker mounting adapter + contactor - MA

For use with	Illustrative picture	Description	Contactors	Reference Code	Weight kg
MPW16/16i MPW25/25i/25t		Used for direct on line starters 45mm width	CWC07...25 CWM9...CWM25	MA45DOL	0.025
MPW16/16i MPW25/25i/25t		Used for reversing starters 90mm width	2 x CWC07...25 CWM9...CWM25	MA90RVS	0.025
MPW16/16i MPW25/25i/25t		Used for star-delta motor starters 90mm width	2 x CWC07...25 CWM9...CWM25	MA90SDS	0.025

Motor Protective Circuit Breakers MPW - Accessories

Three-phase feeder terminal – FTBBS and LST25

For use with	Illustrative picture	Description	Reference Code	Weight kg
MPW16/16i. MPW25/25i/25t		<ul style="list-style-type: none"> - For feeding the commoning blocks; - Rated insulation voltage: 690VAC; - I_n: 63A; - Terminals: 6-25mm² rigid wire and 6-16mm² flexible wire with terminal. 	FTBBS	0.042
MPW25/25i/25t		<ul style="list-style-type: none"> - Block module for " Type E" Combination motor Controller" in accordance with UL (LS+25+MPW+TSB); - Rated insulation voltage: 690VAC; - I_n: 63A. - Terminals: 8-20AWG. 	LST25	0.042

Three-phase commoning blocks for circuit breakers without side fitted auxiliary contacts – BBS45

For use with	Illustrative picture	Description	Numbers of Circuit Breakers	Reference Code	Weight kg
MPW16/16i MPW25/25i/25t		<ul style="list-style-type: none"> - For parallel blocking of side-by-side mounted circuit breakers. without side auxiliary contacts; - Enables the use of frontal auxiliary contact block ACBF-11; - U_n: 690VAC; - I_n: 63A. 	2	BBS45-2	0.044
			3	BBS45-3	0.071
			4	BBS45-4	0.102
			5	BBS45-5	0.122

Three-phase commoning blocks for motor protection circuit breakers with side fitted auxiliary contacts – BBS54

For use with	Illustrative picture	Description	Numbers of Circuit Breakers	Reference Code	Weight kg
MPW16/16i MPW25/25i/25t		<ul style="list-style-type: none"> - For parallel blocking of side-by-side mounted circuit breakers; - Enables the use of side auxiliary contact block ACBS mounted on each motor protective circuit breaker; - U_n: 690VAC; - I_n: 63A. 	2	BBS54-2	0.047
			3	BBS54-3	0.077
			4	BBS54-4	0.102
			5	BBS54-5	0.134

Current Limiter - CLT25

For use with	Illustrative picture	Description	Reference Code	Weight kg
MPW25/25i/25t		<ul style="list-style-type: none"> - For protecting electrical circuits where high short-circuit breaking capacity is required: 100kA @ 500VAC; <p>Note: This accessory must be used together with a MPW motor protective circuit breaker.</p>	CLT25	0.310

Motor Protective Circuit Breakers MPW - Accessories

Shroud for unused terminals – CSD

For use with	Illustrative picture	Description	Reference Code	Weight kg
BBS45 and BBS54		Protection against direct contact to unused terminals on energized BBS45 and BBS54 three-phase commoning block.	CSD	0.020

Scale Cover - SCMP

For use with	Illustrative picture	Description	Reference Code	Weight kg
MPW16 MPW25/25t MPW65		Protects the current adjustment dial against direct contact while enabling the adjusted current to be viewed.	SCMP	0.005

Push-in-lugs - PLMP

For use with	Illustrative picture	Description	Reference Code	Weight kg
MPW16/16i MPW25/25i/25t MPW65/65i		For direct assembly of motor protective circuit breaker onto any surface using screws.	PLMP	0.05

Motor Protective Circuit Breakers MPW - Technical Data

Reference Code	MPW16	MPW16i	MPW25	MPW25i	MPW25t
Maximum Rated Current $I_{max,u}$ (I _n)	16A	16A	32A	32A	32A
Number of poles	3	3	3	3	3
Instantaneous short-circuit	13 x I _n max.	13 x I _n max.	13 x I _n max.	13 x I _n max.	19 x I _n max.
Rated operational voltage U _e	690V ¹⁾	690V ¹⁾	690V ¹⁾	690V ¹⁾	690V ¹⁾
Rated operational frequency ²⁾	50/60Hz	50/60Hz	50/60Hz	50/60Hz	50/60Hz
Insulation Voltage U _i	690V	690V	690V	690V	690V
Rated impulse withstand voltage U _{imp}	6kV	6kV	6kV	6kV	6kV
Utilization category	IEC 60 947-2 (Circuit breaker)	A	A	A	A
	IEC 60 947-4-1 (Motor starter)	AC-3	AC-3	AC-3	AC-3
Tripping Test	Yes	Yes	Yes	Yes	Yes
Overload Protection	Yes	No	Yes	No	No
Phase failure sensitivity	Yes	No	Yes	No	No
Tripping indication	Yes	Yes	Yes	Yes	Yes
Tripping Class	10	-	10	-	-
Maximum operation per hour	Operations/hour	15	15	15	15
Altitude (m)		2000	2000	2000	2000
Degree of protection		IP20	IP20	IP20	IP20
Mechanical life span	Number of operations	100,000	100,000	100,000	100,000
Electrical life span	Number of operations	100,000	100,000	100,000	100,000
Ambient temperatures allowed					
Transport and storage		-50...+80°C	-50...+80°C	-50...+80°C	-50...+80°C
Operation ³⁾		-20...+70°C	-20...+70°C	-20...+70°C	-20...+70°C
Temperature compensation		-20...+60°C	-	-20...+60°C	-
Resistance to Impact (g)		15	15	15	15
Standards					
IEC/EN 60 947-1. DIN VDE 0660 (part 100)		Yes	Yes	Yes	Yes
IEC/EN 60 947-2. DIN VDE 0660 (part 101)		Yes	Yes	Yes	Yes
IEC/EN 60 947-4-1. DIN VDE 0660 (part 102)		Yes	Yes	Yes	Yes
Terminal capacity					
Type of terminal		Flat	Flat	Flat	Flat
Tightening torque	N.m	1.2...1.7	1.2...1.7	2...2.5	2...2.5
	lb.in	11...16	11...16	18...22	18...22
Type of screws		Philips (N°2)	Philips (N°2)	Philips (N°2)	Philips (N°2)
Dimensions					
Width (mm)		45	45	45	45
Height (mm)		90	90	97	97
Depth (mm)		77	77	98	98

Altitude - Correction factor

The MPW motor protective circuit breakers do not undergo any change to their specified performance when applied at an altitude of up to 2000 meters above sea level. However, as the altitude increases, the atmospheric properties vary in terms of dielectric rigidity and pressure. Therefore, current and voltage correction factors must be applied for altitudes exceeding 2000 meters, as shown in the table on the right:

Altitude (above sea level) - h	Rated operational voltage U _e	Current correction factor I _u
h ≤ 2000 m	690 V	1 x I _u
2000 < h ≤ 3000 m	550 V	0,96 x I _u
3000 < h ≤ 4000 m	480 V	0,93 x I _u
4000 < h ≤ 5000 m	420 V	0,90 x I _u

Notes: 1) 500V with plastic box;

2) On request: 0 to 400Hz

3) Reduce current for temperatures exceeding +60°C (87% to 70°C)

Motor Circuit Breakers MPW - Technical Data

Reference Code		MPW65	MPW65i	MPW100
Maximum Rated Current $I_{max}(I_b)$		65A	65A	100A
Number of poles		3	3	3
Instantaneous short-circuit		13 x I_b max.	13 x I_b max.	13 x I_b max.
Rated operational voltage U_e		690V	690V	690V
Rated operational frequency ¹⁾		50/60Hz	50/60Hz	50/60Hz
Insulation Voltage U_i		690V	690V	1000V
Rated impulse withstand voltage U_{imp}		6kV	6kV	8kV
Utilization category	IEC 60 947-2 (Circuit breaker)	A	A	A
	IEC 60 947-4-1 (Motor starter)	AC-3	AC-3	AC-3
Tripping Test		Yes	Yes	Yes
Overload Protection		Yes	No	Yes
Phase failure sensitivity		Yes	No	Yes
Tripping indication		Yes	Yes	Yes
Tripping Class		10	-	10
Maximum operating frequency	Operations/hour	15	15	25
Altitude (m)		2000	2000	2000
Degree of protection		IP20	IP20	IP20
Mechanical life span	Number of operations	50,000	50,000	50,000
Electrical life span	Number of operations	25,000	25,000	25,000
Ambient temperatures allowed				
Transport and storage		-50...+80°C	-50...+80°C	-50...+80°C
Operation ²⁾		-20...+70°C	-20...+70°C	-20...+60°C
Temperature compensation		-20...+60°C	-	-20...+60°C
Resistance to Impact (g)		15	15	25
Standards				
IEC/EN 60 947-1, DIN VDE 0660 (part 100)		Yes	Yes	Yes
IEC/EN 60 947-2, DIN VDE 0660 (part 101)		Yes	Yes	Yes
IEC/EN 60 947-4-1, DIN VDE 0660 (part 102)		Yes	Yes	Yes
Terminal capacity				
Type of terminal		Box	Box	Box
Tightening torque	N.m	4...6	4...6	4...6
	lb.in	35...55	35...55	35...53
Type of screws		Allen (4mm)	Allen (4mm)	Allen (4mm)
Dimensions				
Width (mm)		54	54	70
Height (mm)		125	125	165
Depth (mm)		157	157	171

DC operation

The MPW16, MPW25 and MPW65 motor protective circuit breakers can also be used for operating continuous current loads. For such operation it is necessary to connect 2 or 3 poles in series.

See recommended circuits and their voltage limits in the table on the right.

Time constant $t = 5$ ms

Short-circuit breaking capacity $I_{cu} = 10$ kA for all configurations

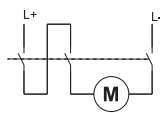
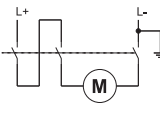
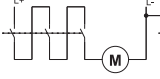
Circuits	Max. VDC	Notes
	150 VDC	System not grounded 2 pole series connected
	300 VDC	System grounded 2 pole series connected
	450 VDC	System grounded 3 pole series connected

Notes: 1) On request: 0 to 400Hz

2) Reduce current for temperatures exceeding +60°C (87% to 70°C)

Motor Protective Circuit Breakers MPW - Technical Data

Main Terminal Capacity

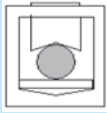
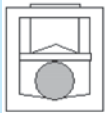
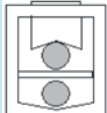
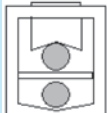
Reference Code	Type	Number of conductors	Cross-Section
MPW16/16i	Rigid or flexible cable	1 or 2	1...4 mm ² 18...12 AWG
MPW25/25i/25t	Rigid or flexible cable	1 or 2	1...2.5 mm ² 2.5...6 mm ² 14...8 AWG ¹⁾
MPW65/65t	Type	1 conductor connection in upper part only	Cross-Section
	Rigid cable		1...35 mm ²
	Cable without terminal		1.5...35 mm ²
	Cable with terminal		1...35 mm ²
	Flexible cable		1.5...35 mm ² 17...2 AWG
	Type	1 conductor connection in lower part only	Cross-Section
	Rigid cable		2.5...35mm ²
	Cable without terminal		6...35mm ²
	Cable with terminal		2.5...35mm ²
	Flexible cable		6...35mm ² 13...2 AWG
	Type	Connection of 2 conductors - Conductor in upper part	Cross-Section
	Rigid cable		1...35mm ²
	Cable without terminal		1.5...35mm ²
	Cable with terminal		1...35mm ²
	Flexible cable		1.5...35mm ² 17...2 AWG
	Type	Conductor in lower part	Cross-Section
	Rigid cable		2.5...35mm ²
	Cable without terminal		6...35mm ²
	Cable with terminal		2.5...35mm ²
	Flexible cable		6...35mm ² 13...2 AWG
MPW100	Type	Number of conductors	Cross-Section
	Rigid cable	1	2.5...70 mm ² 12...2/0 AWG
		2	2.5...50 mm ² 12...1/0 AWG
	Flexible cable	1	2.5...50 mm ² 12...1/0 AWG
		2	2.5...35 mm ² 10...2 AWG

Note: 1) 8 AWG for flexible cable only

Motor Protective Circuit Breakers MPW - Technical Data

Auxiliary Contact Block - ACB

Reference Code	ACBF-11			ACBS-11. ACBS-20. ACBS-02. TSB			
For use with	MPW16/16i. MPW25/25i/25t. MPW65/65i						
Utilization Category	24 VAC	220-230 VAC		24 VAC	230 VAC	400 VAC	690 VAC
AC-15	2 A	0.5 A		6 A	6 A	3 A	1 A
AC-12	2.5 A		2.5 A	10 A	10 A	10 A	10 A
DC-13	24 VDC	48 VDC	60 VDC	24 VDC	110 VDC	220 VDC	440 VDC
	1 A	0.3 A	0.15 A	2 A	0.5 A	0.25 A	0.1 A
Type of terminal	Flat						
Type of screw	Philips (N°2)						
Tightening torque	0.8...1.2 N.m (7...10 lb.in)						
Rigid cable	1 or 2 x (0.5...1.5 mm ²). 1 or 2 x (0.75...2.5 mm ²). 2 x (18...14 AWG)						
Flexible cable							
Backup fuses gL/gG	10 A						

Reference Code	ACBF-11 MPW100		ACBS-11/ACBS-20/ACBS-02/TSB AT-11 MPW100	
For use with	MPW100			
Utilization Category	240 VAC		24 VAC	240 VAC
AC-15	3 A		6 A	4 A
DC-13	24 VDC	220VDC	24 VDC	220VDC
	1 A	0.1 A	2 A	0.25 A
Type of screw	Philips (N°2)			
Tightening torque	0.8...1.2 N.m (7...10 lb.in)			
Rigid cable	1 (0.5...2.5mm ² / 20...14 AWG)		1 or 2 x (0.5...2.5mm ² / 20...14 AWG)	
Flexible cable	1(0.5...4mm ² / 20...10 AWG) or 2(0.75...2.5mm ² / 18...14 AWG)			
Back-up fuses gL/gG	16 A			

Undervoltage Release - URMP

Reference Code	URMP		URMP V__ MPW100	
For use with	MPW16/16i. MPW25/25i/25t. MPW65/65i		MPW100	
Operating voltage (Enables cir. breaker switch on)	0.85...1.1xU _s			
Non-operating voltage (guarantees circuit breaker switch OFF)	0.7...0.35xU _s			
Energization Consumption	20.2 VA / 13 W		8.5 VA / 6 W	
Consumption	7.2 VA / 2.4 W		3 VA / 1.2 W	
Max. opening time	20 ms			
Type of terminal	Flat			
Type of screws	Philips (N°2)			
Tightening torque	0.8...1.2 N.m (7...10 lb.in)			
Rigid cable	1 or 2 x (0.5...1.5 mm ²). 1 or 2 x (0.75...2.5 mm ²). 2 x (18...14 AWG)		1 or 2 x (0.5...2.5 mm ² / 20...14 AWG)	
Flexible cable			1 (0.5...4 mm ² / 20...10 AWG) or 2 x (0.75...2.5 mm ² / 18...14 AWG)	
Back-up fuses gL/gG	10 A			

Shunt Release - SRMP

Reference Code	SRMP		SRMP-K_ MPW100	
For use with	MPW16/16i. MPW25/25i/25t. MPW65/65i		MPW100	
Operating Voltage (guarantee circuit breaker switch OFF)	0.7...1.1xU _s			
Consumption - Energization	20.2 VA / 13 W		8.5 VA / 6 W	
Maximum opening time	20 ms			
Type of terminal	Flat			
Type of screw	Philips (N°2)			
Tightening torque	0.8...1.2 N.m (7...10 lb.in)			
Rigid cable	1 or 2 x (0.5...1.5 mm ²). 1 or 2 x (0.75...2.5 mm ²). 2 x (18...14 AWG)		1 or 2 x (0.5...2.5 mm ² / 20...14 AWG)	
Flexible cable			1 (0.5...4 mm ² / 20...10 AWG) or 2 x (0.75...2.5 mm ² / 18...14 AWG)	
Back-up fuses gL/gG	10 A			

Motor Protective Circuit Breakers MPW25 - Coordination Tables

Type “1” Coordination - Rated conditional short-circuit current $I_q = 50 \text{ kA}/400\text{-}415 \text{ V}$

Direct-on-line starters

Direct-on-line starters consists of a motor protective circuit breaker MPW25 and CWM contactor, which are already electrically and mechanically connected via the block module ECCMP

Rated operational 400-415 V AC-3 (kW)	Rated operational power I_e (A)	Setting overload release  I_r (A)	Reference Code Motor Protective Circuit Breaker	Reference Code Contactors Actualing Voltage (230V 50/60Hz)
0.06	0.21	0.16...0.25	MPW25-3-C025	CWM9-10-30D24(230V 50/60Hz)
0.09	0.31	0.25...0.4	MPW25-3-D004	CWM9-10-30D24(230V 50/60Hz)
0.12	0.41	0.4...0.63	MPW25-3-C063	CWM9-10-30D24(230V 50/60Hz)
0.18	0.6	0.4...0.63	MPW25-3-C063	CWM9-10-30D24(230V 50/60Hz)
0.25	0.8	0.63...1.0	MPW25-3-U001	CWM9-10-30D24(230V 50/60Hz)
0.37	1.1	1.0...1.6	MPW25-3-D016	CWM9-10-30D24(230V 50/60Hz)
0.55	1.5	1.0...1.6	MPW25-3-D016	CWM9-10-30D24(230V 50/60Hz)
0.75	1.9	1.6...2.5	MPW25-3-D025	CWM9-10-30D24(230V 50/60Hz)
1.1	2.6	2.5...4.0	MPW25-3-U004	CWM9-10-30D24(230V 50/60Hz)
1.5	3.6	2.5...4.0	MPW25-3-U004	CWM9-10-30D24(230V 50/60Hz)
2.2	5	4.0...6.3	MPW25-3-D063	CWM9-10-30D24(230V 50/60Hz)
3.0	6.6	6.3...10	MPW25-3-U010	CWM9-10-30D24(230V 50/60Hz)
4.0	8.5	6.3...10	MPW25-3-U010	CWM9-10-30D24(230V 50/60Hz)
5.5	11.3	10...16	MPW25-3-U016	CWM12-10-30D24(230V 50/60Hz)
7.5	15.2	10...16	MPW25-3-U016	CWM18-10-30D24(230V 50/60Hz)
9.2	17.8	16...20	MPW25-3-U020	CWM18-10-30D24(230V 50/60Hz)
11	21.7	20...25	MPW25-3-U025	CWM25-10-30D24(230V 50/60Hz)
15	29.3	25...32	MPW25-3-U032	CWM32-10-30D24(230V 50/60Hz)

Ordering example: The type can be found in the “Rated operation power” column alongside the selected rating 2,2kW, desired type: MPW25-3-D063 + CWM9-10-30D24(230V 50/60Hz).

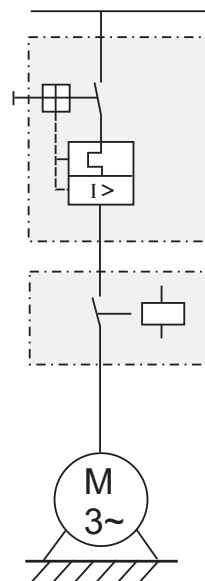

Motor Protective Circuit Breakers MPW25 - Coordination Tables

Type “1” Coordination - Rated conditional short-circuit current $I_q = 50 \text{ kA}/400\text{-}415 \text{ V}$

Direct-on-line starters

Direct-on-line starters consists of a motor protective circuit breaker MPW25i and CWM contactor, which are already electrically and mechanically connected via the block module ECCMP

Rated operational 400-415 V AC-3 (kW)	Rated operational power I_b (A)	Operational Instalaneous Current I_{in} (A)	Reference Code Motor Protective Circuit Breaker	Reference Code Contactors Actuating Voltage (230V 50/60Hz)
0.06	0.21	0.25	MPW25i-3-C025	CWM9-10-30D24(230V 50/60Hz)
0.09	0.31	0.4	MPW25i-3-D004	CWM9-10-30D24(230V 50/60Hz)
0.12	0.41	0.63	MPW25i-3-C063	CWM9-10-30D24(230V 50/60Hz)
0.18	0.6	0.63	MPW25i-3-C063	CWM9-10-30D24(230V 50/60Hz)
0.25	0.8	1.0	MPW25i-3-U001	CWM9-10-30D24(230V 50/60Hz)
0.37	1.1	1.6	MPW25i-3-D016	CWM9-10-30D24(230V 50/60Hz)
0.55	1.5	1.6	MPW25i-3-D016	CWM9-10-30D24(230V 50/60Hz)
0.75	1.9	2.5	MPW25i-3-D025	CWM9-10-30D24(230V 50/60Hz)
1.1	2.6	4.0	MPW25i-3-U004	CWM9-10-30D24(230V 50/60Hz)
1.5	3.6	4.0	MPW25i-3-U004	CWM9-10-30D24(230V 50/60Hz)
2.2	5	6.3	MPW25i-3-D063	CWM9-10-30D24(230V 50/60Hz)
3.0	6.6	10	MPW25i-3-U010	CWM9-10-30D24(230V 50/60Hz)
4.0	8.5	10	MPW25i-3-U010	CWM9-10-30D24(230V 50/60Hz)
5.5	11.3	16	MPW25i-3-U016	CWM12-10-30D24(230V 50/60Hz)
7.5	15.2	16	MPW25i-3-U016	CWM18-10-30D24(230V 50/60Hz)
9.2	17.8	20	MPW25i-3-U020	CWM18-10-30D24(230V 50/60Hz)
11	21.7	25	MPW25i-3-U025	CWM25-10-30D24(230V 50/60Hz)
15	29.3	32	MPW25i-3-U032	CWM32-10-30D24(230V 50/60Hz)

Ordering example: The type can be found in the “Rated operational power” column alongside the selected rating 2,2 kW, desired type: MPW25i-3-D063 + CWM9-10-30D24(230V 50/60Hz)

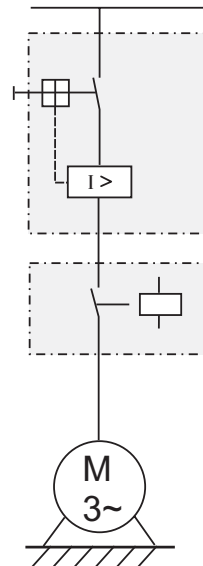

Motor Protective Circuit Breakers MPW25 - Coordination Tables

Type “2” Coordination - Rated conditional short-circuit current $I_q = 50/65kA$ in 400-415 V

Direct-on-line starters

Direct-on-line starters consists of a motor protective circuit breaker MPW25 and CWM contactor, which are already electrically and mechanically connected via the block module ECCMP up to 32A.

Rated operational 400-415 V AC-3 (kW)	Rated operational power I_b (A)	Setting overload release  I_r (A)	Reference Code Motor Protective Circuit Breaker	$I_q = 50kA$	$I_q = 65kA$
				Reference Code Contactors Actuating Voltage (230V 50/60Hz)	Reference Code Contactors Actuating Voltage (230V 50/60Hz)
0.06	0.21	0.16...0.25	MPW25-3-C025	CWM9-10-30D24(230V 50/60Hz)	CWM9-10-30D24(230V 50/60Hz)
0.09	0.31	0.25...0.4	MPW25-3-D004	CWM9-10-30D24(230V 50/60Hz)	CWM9-10-30D24(230V 50/60Hz)
0.12	0.41	0.4...0.63	MPW25-3-C063	CWM9-10-30D24(230V 50/60Hz)	CWM9-10-30D24(230V 50/60Hz)
0.18	0.6	0.4...0.63	MPW25-3-C063	CWM9-10-30D24(230V 50/60Hz)	CWM9-10-30D24(230V 50/60Hz)
0.25	0.8	0.63...1.0	MPW25-3-U001	CWM9-10-30D24(230V 50/60Hz)	CWM9-10-30D24(230V 50/60Hz)
0.37	1.1	1.0...1.6	MPW25-3-D016	CWM9-10-30D24(230V 50/60Hz)	CWM9-10-30D24(230V 50/60Hz)
0.55	1.5	1.0...1.6	MPW25-3-D016	CWM9-10-30D24(230V 50/60Hz)	CWM9-10-30D24(230V 50/60Hz)
0.75	1.9	1.6...2.5	MPW25-3-D025	CWM9-10-30D24(230V 50/60Hz)	CWM9-10-30D24(230V 50/60Hz)
1.1	2.6	2.5...4.0	MPW25-3-U004	CWM9-10-30D24(230V 50/60Hz)	CWM25-10-30D24(230V 50/60Hz)
1.5	3.6	2.5...4.0	MPW25-3-U004	CWM9-10-30D24(230V 50/60Hz)	CWM25-10-30D24(230V 50/60Hz)
2.2	5	4.0...6.3	MPW25-3-D063	CWM9-10-30D24(230V 50/60Hz)	CWM25-10-30D24(230V 50/60Hz)
3.0	6.6	6.3...10	MPW25-3-U010	CWM9-10-30D24(230V 50/60Hz)	CWM32-10-30D24(230V 50/60Hz)
4.0	8.5	6.3...10	MPW25-3-U010	CWM9-10-30D24(230V 50/60Hz)	CWM32-10-30D24(230V 50/60Hz)
5.5	11.3	10...16	MPW25-3-U016	CWM12-10-30D24(230V 50/60Hz)	CWM32-10-30D24(230V 50/60Hz)
7.5	15.2	10...16	MPW25-3-U016	CWM18-10-30D24(230V 50/60Hz)	CWM32-10-30D24(230V 50/60Hz)
9.2	17.8	16...20	MPW25-3-U020	CWM18-10-30D24(230V 50/60Hz)	CWM32-10-30D24(230V 50/60Hz)
11	21.7	20...25	MPW25-3-U025	CWM25-10-30D24(230V 50/60Hz)	CWM40-10-30D24(230V 50/60Hz)
15	29.3	25...32	MPW25-3-U032	CWM50-10-30D24(230V 50/60Hz)	CWM50-10-30D24(230V 50/60Hz)

Ordering example: The type can be found in the “Rated operation power” column alongside the selected rating 2,2kW, desired type: MPW25-3-D063 + CWM9-10-30D24(230V 50/60Hz).

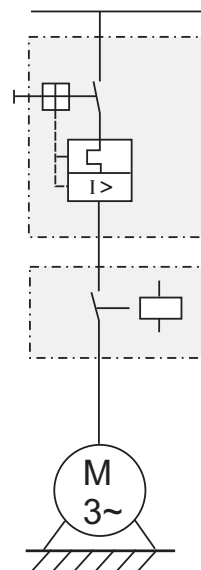

Motor Protective Circuit Breakers MPW25 - Coordination Tables

Type “2” Coordination - Rated conditional short-circuit current $I_q = 50/65\text{kA}$ in 400-415 V

Direct-on-line starters

Direct-on-line starters consists of a motor protective circuit breaker MPW25i and CWM contactor, which are already electrically and mechanically connected via the block module ECCMP up to 32A.

Rated operational 400-415 V AC-3 (kW)	Rated operational power I_p (A)	Operational Instalaneous Current I_{in} (A)	Reference Code Motor Protective Circuit Breaker	$I_q = 50\text{kA}$	$I_q = 65\text{kA}$
				Reference Code Contactors Actuating Voltage (230V 50/60Hz)	Reference Code Contactors Actuating Voltage (230V 50/60Hz)
0.06	0.21	0.25	MPW25i-3-C025	CWM9-10-30D24(230V 50/60Hz)	CWM9-10-30D24(230V 50/60Hz)
0.09	0.31	0.4	MPW25i-3-D004	CWM9-10-30D24(230V 50/60Hz)	CWM9-10-30D24(230V 50/60Hz)
0.12	0.41	0.63	MPW25i-3-C063	CWM9-10-30D24(230V 50/60Hz)	CWM9-10-30D24(230V 50/60Hz)
0.18	0.6	0.63	MPW25i-3-C063	CWM9-10-30D24(230V 50/60Hz)	CWM9-10-30D24(230V 50/60Hz)
0.25	0.8	1.0	MPW25i-3-U001	CWM9-10-30D24(230V 50/60Hz)	CWM9-10-30D24(230V 50/60Hz)
0.37	1.1	1.6	MPW25i-3-D016	CWM9-10-30D24(230V 50/60Hz)	CWM9-10-30D24(230V 50/60Hz)
0.55	1.5	1.6	MPW25i-3-D016	CWM9-10-30D24(230V 50/60Hz)	CWM9-10-30D24(230V 50/60Hz)
0.75	1.9	2.5	MPW25i-3-D025	CWM9-10-30D24(230V 50/60Hz)	CWM9-10-30D24(230V 50/60Hz)
1.1	2.6	4.0	MPW25i-3-U004	CWM9-10-30D24(230V 50/60Hz)	CWM25-10-30D24(230V 50/60Hz)
1.5	3.6	4.0	MPW25i-3-U004	CWM9-10-30D24(230V 50/60Hz)	CWM25-10-30D24(230V 50/60Hz)
2.2	5	6.3	MPW25i-3-D063	CWM9-10-30D24(230V 50/60Hz)	CWM25-10-30D24(230V 50/60Hz)
3.0	6.6	10	MPW25i-3-U010	CWM9-10-30D24(230V 50/60Hz)	CWM32-10-30D24(230V 50/60Hz)
4.0	8.5	10	MPW25i-3-U010	CWM9-10-30D24(230V 50/60Hz)	CWM32-10-30D24(230V 50/60Hz)
5.5	11.3	16	MPW25i-3-U016	CWM12-10-30D24(230V 50/60Hz)	CWM32-10-30D24(230V 50/60Hz)
7.5	15.2	16	MPW25i-3-U016	CWM18-10-30D24(230V 50/60Hz)	CWM32-10-30D24(230V 50/60Hz)
9.2	17.8	20	MPW25i-3-U020	CWM18-10-30D24(230V 50/60Hz)	CWM32-10-30D24(230V 50/60Hz)
11	21.7	25	MPW25i-3-U025	CWM25-10-30D24(230V 50/60Hz)	CWM40-10-30D24(230V 50/60Hz)
15	28.93	32	MPW25i-3-U032	CWM50-10-30D24(230V 50/60Hz)	CWM50-10-30D24(230V 50/60Hz)

Ordering example: The type can be found in the “Rated operational power” column alongside the selected rating 2,2 kW, desired type: MPW25i-3-D063 + CWM9-10-30D24(230V 50/60Hz)

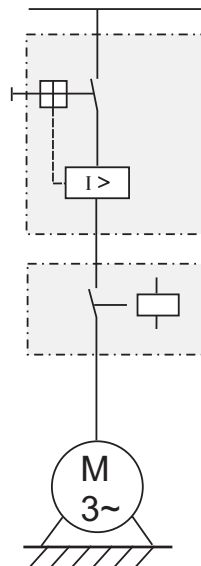

Motor Protective Circuit Breakers MPW - Rated Short-Circuit Breaking Capacity (IEC 60947-2)

MPW16 / MPW25 / MPW65

Reference Code	Setting Overload Release (A)	220-230VAC			380-415VAC			440VAC			460-500VAC			630-690VAC		
		I _{cu}	I _{cs}	Max. Fuse (gL/gG)	I _{cu}	I _{cs}	Max. Fuse (gL/gG) ¹⁾	I _{cu}	I _{cs}	Max. Fuse (gL/gG) ¹⁾	I _{cu}	I _{cs}	Max. Fuse (gL/gG) ¹⁾	I _{cu}	I _{cs}	Max. Fuse (gL/gG) ¹⁾
		kA	kA	A	kA	kA	A	kA	kA	A	kA	kA	A	kA	kA	A
MPW16	0.10...0.16	100	100	-	100	100	-	100	100	-	100	100	-	10	10	-
	0.16...0.25	100	100	-	100	100	-	100	100	-	100	100	-	10	10	-
	0.25...0.4	100	100	-	100	100	-	100	100	-	100	100	-	10	10	-
	0.4...0.63	100	100	-	100	100	-	100	100	-	100	100	-	10	10	-
	0.63...1	100	100	-	100	100	-	100	100	-	100	100	-	10	10	-
	1...1.6	100	100	-	100	100	-	100	100	-	100	100	-	10	10	-
	1.6...2.5	100	100	-	100	100	-	100	100	-	100	100	-	8	8	25
	2.5...4	100	100	-	100	100	-	100	100	-	100	100	-	8	8	35
	4...6.3	100	100	-	100	100	-	100	100	-	100	100	-	8	8	50
6.3...10	100	100	-	50	10	100	50	10	80	10	10	63	5	5	50	
10...16	100	100	-	10	10	100	10	10	80	10	10	80	4	3	63	
MPW25	0.10...0.16	100	100	-	100	100	-	100	100	-	100	100	-	100	100	-
	0.16...0.25	100	100	-	100	100	-	100	100	-	100	100	-	100	100	-
	0.25...0.4	100	100	-	100	100	-	100	100	-	100	100	-	100	100	-
	0.4...0.63	100	100	-	100	100	-	100	100	-	100	100	-	100	100	-
	0.63...1	100	100	-	100	100	-	100	100	-	100	100	-	100	100	-
	1...1.6	100	100	-	100	100	-	100	100	-	100	100	-	100	100	-
	1.6...2.5	100	100	-	100	100	-	100	100	-	100	100	-	8	8	25
	2.5...4	100	100	-	100	100	-	100	100	-	100	100	-	8	8	32
	4...6.3	100	100	-	100	100	-	100	100	-	100	100	-	8	8	50
	6.3...10	100	100	-	100	100	-	50	25	80	42	21	63	8	8	50
	10...16	100	100	-	50	25	100	50	15	80	10	8	80	5	5	63
16...20	100	100	-	50	25	125	50	15	80	10	8	80	5	5	63	
20...25	100	100	-	50	25	125	50	15	100	10	8	80	5	5	63	
25...32	100	100	-	50	25	125	25	15	100	10	8	80	5	5	63	
MPW65	10...16	100	100	-	50	50	100	50	50	80	15	15	80	8	8	63
	16...20	100	100	-	50	50	125	50	50	80	15	15	80	8	8	63
	20...25	100	100	-	50	50	125	50	50	100	15	15	80	8	8	63
	25...32	100	100	-	50	50	125	50	50	100	15	15	80	5	5	63
	32...40	100	100	-	50	50	160	50	50	125	15	10	100	5	5	63
	40...50	100	100	-	50	50	160	50	50	125	15	10	100	5	5	80
50...65	100	100	-	50	50	160	50	50	125	15	10	100	5	5	80	

MPW100

Reference Code	Setting Overload Release (A)	220-240 VAC			380-415 VAC			440-460 VAC			500-525 VAC			600-690 VAC		
		I _{cu}	I _{cs}	Max. Fuse (gL/gG)	I _{cu}	I _{cs}	Max. Fuse (gL/gG) ¹⁾	I _{cu}	I _{cs}	Max. Fuse (gL/gG) ¹⁾	I _{cu}	I _{cs}	Max. Fuse (gL/gG) ¹⁾	I _{cu}	I _{cs}	Max. Fuse (gL/gG) ¹⁾
		kA	kA	A	kA	kA	A	kA	kA	A	kA	kA	A	kA	kA	A
MPW100	55...75	100	100	-	75	50	-	50	38	200	12	9	160	6	6	125
	70...90	100	100	-	75	50	-	50	38	200	12	9	160	6	6	160
	80...100	100	100	-	75	50	-	50	38	200	12	9	160	6	6	160

Self protected against short-circuits up to 100kA

- Back-up fuse not required

1) Fuse amounts required for greater short-circuit currents.

UL values on request

Motor Protective Circuit Breakers MPW - Rated Short-Circuit Breaking Capacity (IEC 60947-2) - Limiter Function

MPW25 + CLT25

Reference Code	Setting Overload Release (A)	380-415VAC			440VAC			460-500VAC			630-690VAC		
		I_{cu}	I_{cs}	Max. Fuse (gL/gG)	I_{cu}	I_{cs}	Max. Fuse (gL/gG)	I_{cu}	I_{cs}	Max. Fuse (gL/gG)	I_{cu}	I_{cs}	Max. Fuse (gL/gG)
		kA	kA	A	kA	kA	A	kA	kA	A	kA	kA	A
MPW25 + CLT25	0.10...0.16	◆	◆	-	◆	◆	-	◆	◆	-	◆	◆	-
	0.16...0.25	◆	◆	-	◆	◆	-	◆	◆	-	◆	◆	-
	0.25...0.4	◆	◆	-	◆	◆	-	◆	◆	-	◆	◆	-
	0.4...0.63	◆	◆	-	◆	◆	-	◆	◆	-	◆	◆	-
	0.63...1	◆	◆	-	◆	◆	-	◆	◆	-	◆	◆	-
	1...1.6	◆	◆	-	◆	◆	-	◆	◆	-	◆	◆	-
	1.6...2.5	◆	◆	-	◆	◆	-	◆	◆	-	50	50	-
	2.5...4	◆	◆	-	◆	◆	-	◆	◆	-	50	50	-
	4...6.3	◆	◆	-	◆	◆	-	◆	◆	-	50	50	-
	6.3...10	◆	◆	-	100	100	-	100	100	-	50	50	-
	10...16	100	100	-	100	100	-	100	100	-	50	50	-
	16...20	100	100	-	100	100	-	100	100	-	50	50	-
20...25	100	100	-	100	100	-	100	100	-	10	10	-	
25...32	100	100	-	100	100	-	100	100	-	10	10	-	

MPW65 + MPW65i

Reference Code	Setting Overload Release (A)	380-415VAC			440VAC			460-500VAC			630-690VAC		
		I_{cu}	I_{cs}	Max. Fuse (gG/gL)	I_{cu}	I_{cs}	Max. Fuse (gG/gL)	I_{cu}	I_{cs}	Max. Fuse (gG/gL)	I_{cu}	I_{cs}	Max. Fuse (gG/gL)
		kA	kA	A	kA	kA	A	kA	kA	A	kA	kA	A
MPW65 + MPW65i-3-U065	10...16	65	65	-	65	65	-	65	65	-	25	25	-
	16...20	65	65	-	65	65	-	65	65	-	25	25	-
	20...25	65	65	-	65	65	-	65	65	-	25	25	-
	25...32	65	65	-	65	65	-	65	65	-	25	25	-
	32...40	65	65	-	65	65	-	65	65	-	25	25	-
	40...50	65	65	-	65	65	-	65	65	-	25	25	-
	50...65	65	65	-	65	65	-	65	65	-	25	25	-

Self protected against short-circuits up to 100kA

- Back-up fuse not required

1) Fuse amounts required for higher short-circuit currents.

◆ Not applicable due to MPW25/MPW65 already having 100 kA of I_{cu} / I_{cs} in referred ranges.

Motor Protective Circuit Breakers MPW - Characteristics Curves

The tripping characteristic shows the motor circuit breaker trip time in relation to the rated current.

The curves show average tolerance range values for an ambient temperature of 20°C, starting in cold state. Thermal trip time when working in operating temperature is reduced to around 25% of the presented values. Under normal operating conditions, all 3 circuit breaker phases must be conducting.

MPW16/25/65

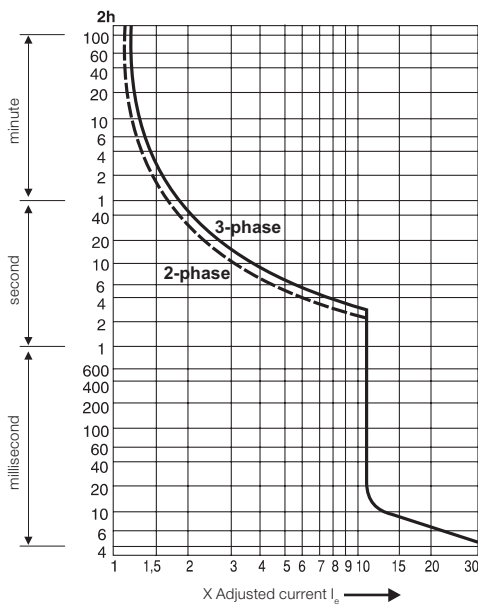

MPW16i/25i/65i

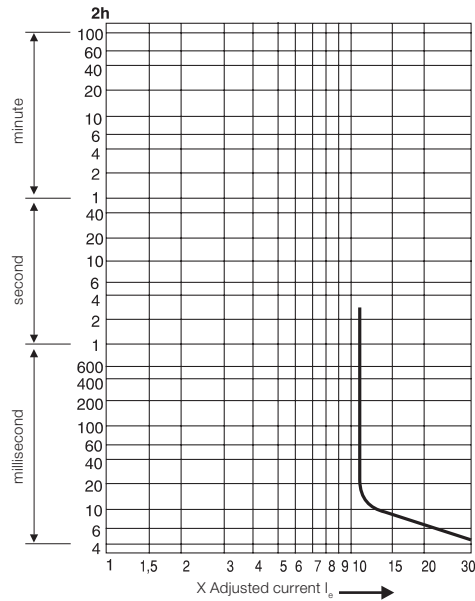

Characteristic I²t at 415V - MPW25/25i

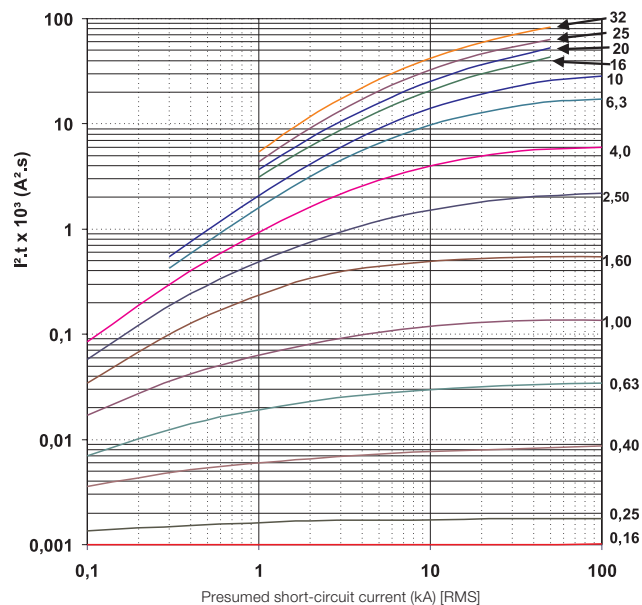

Note: 1) Other characteristic curves on request

Motor Protective Circuit Breakers MPW - Tripping Characteristic Curves

MPW100

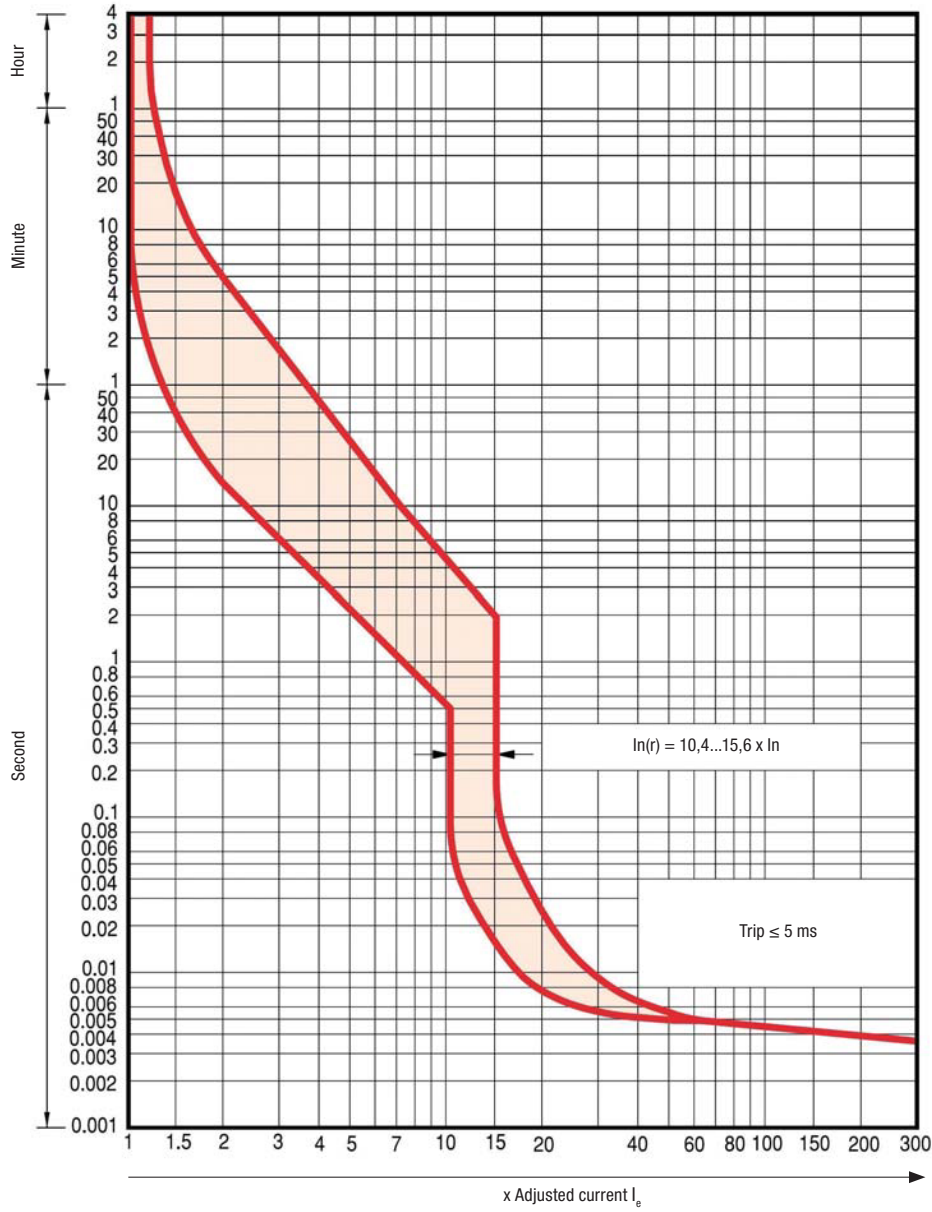

Notes: 1) Thermal Tripping current: Curve presented for an ambient temperature of 20°C starting from cold state.
 2) Magnetic Tripping Current: Corresponds to 13 times the maximum adjustment range value.

Connection Diagrams and Typical Circuits

Connection Diagrams

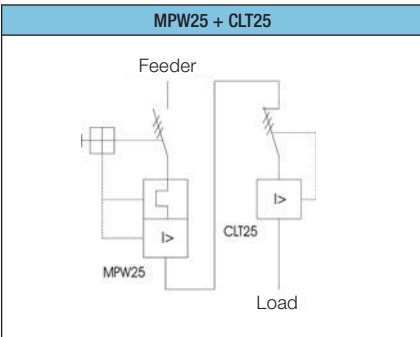
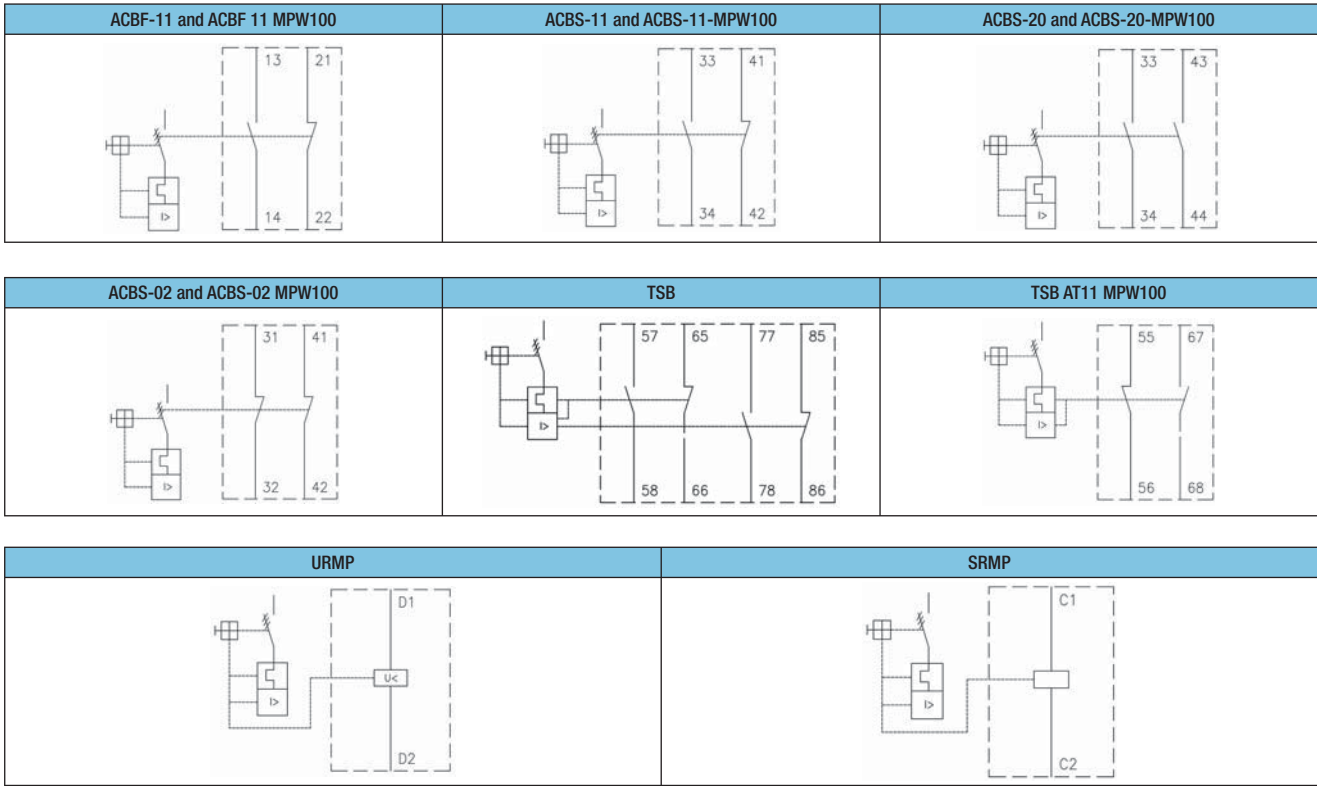

Typical Circuits

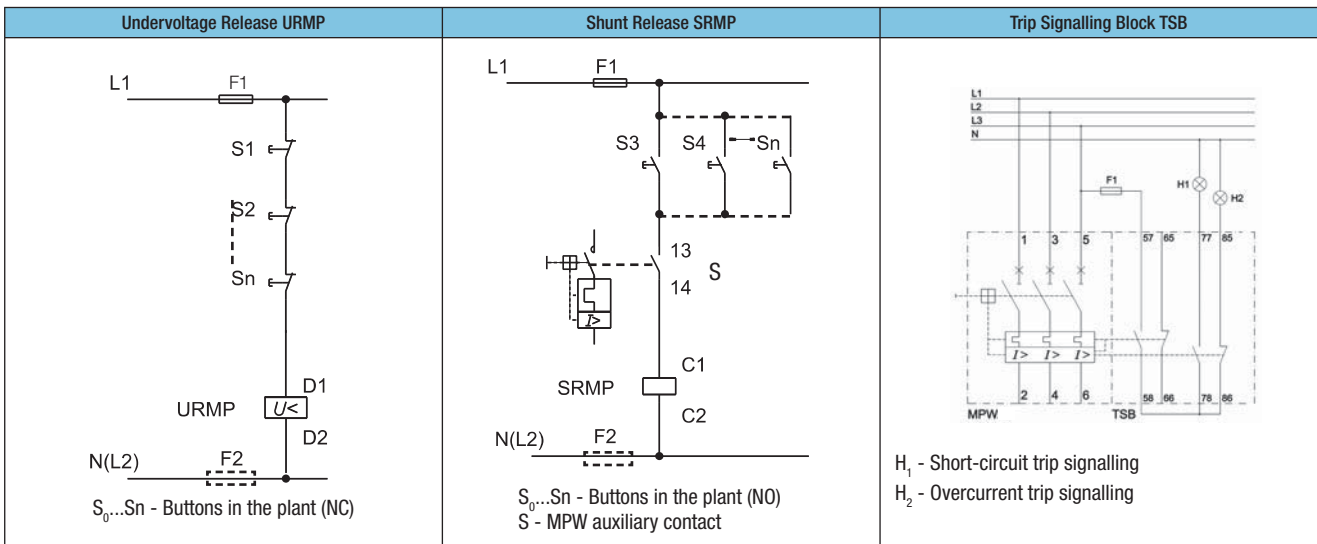

Motor Protective Circuit Breaker MPW - Dimensions (mm)

MPW16 + Accessories

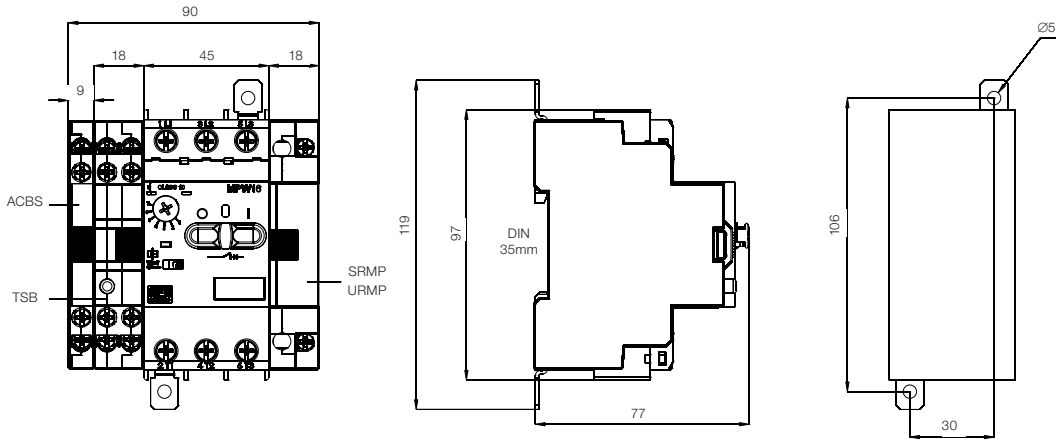

Mounting Position

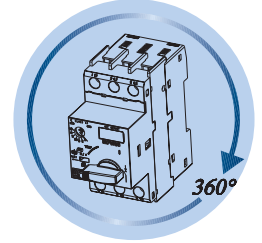

MPW16 + CWC07...16

Insulated Enclosure - MPE66 (IP66)

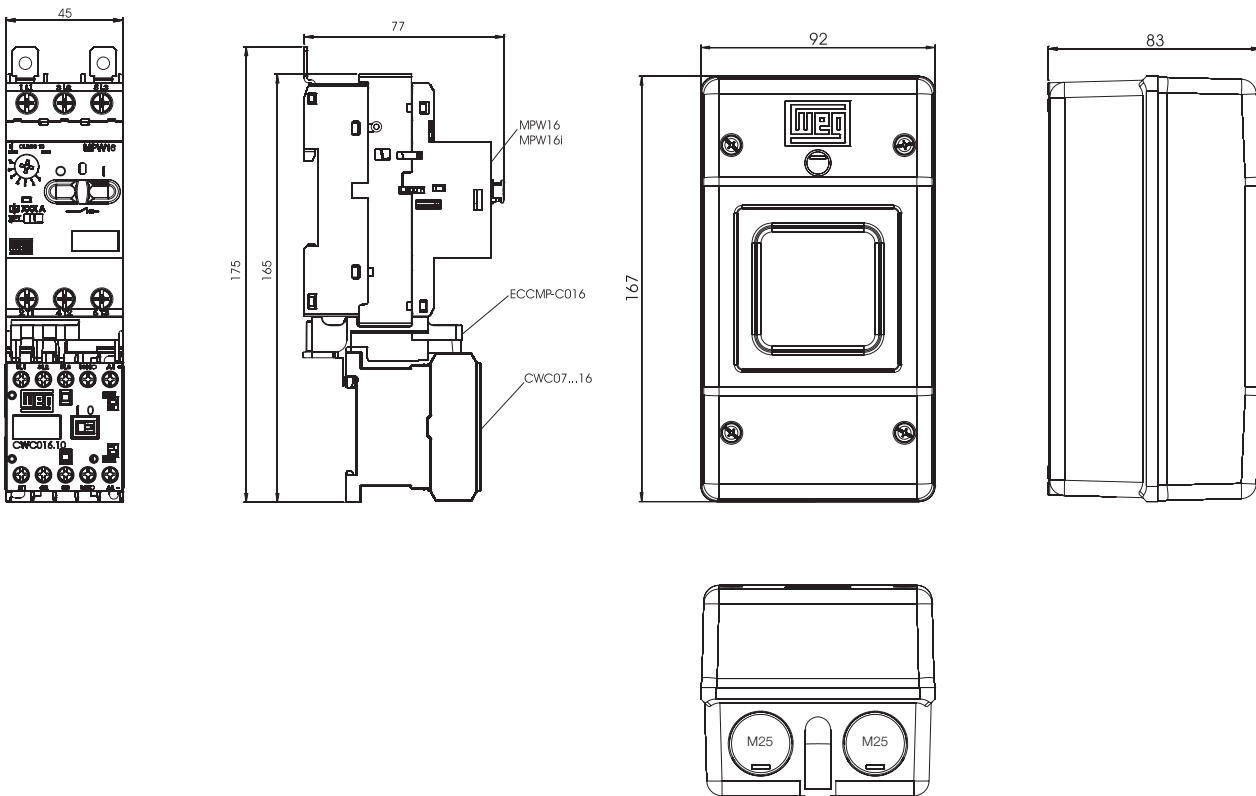

Motor Protective Circuit Breaker MPW - Dimensions (mm)

MPW25 + Accessories

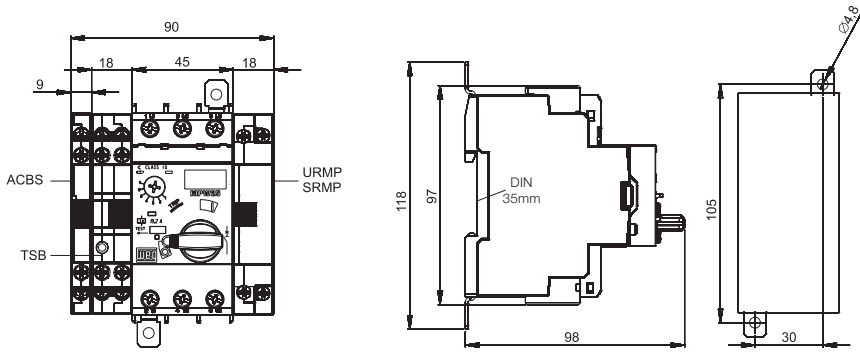

Mounting Position

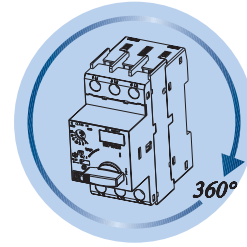

MPW25 + CWC07...16

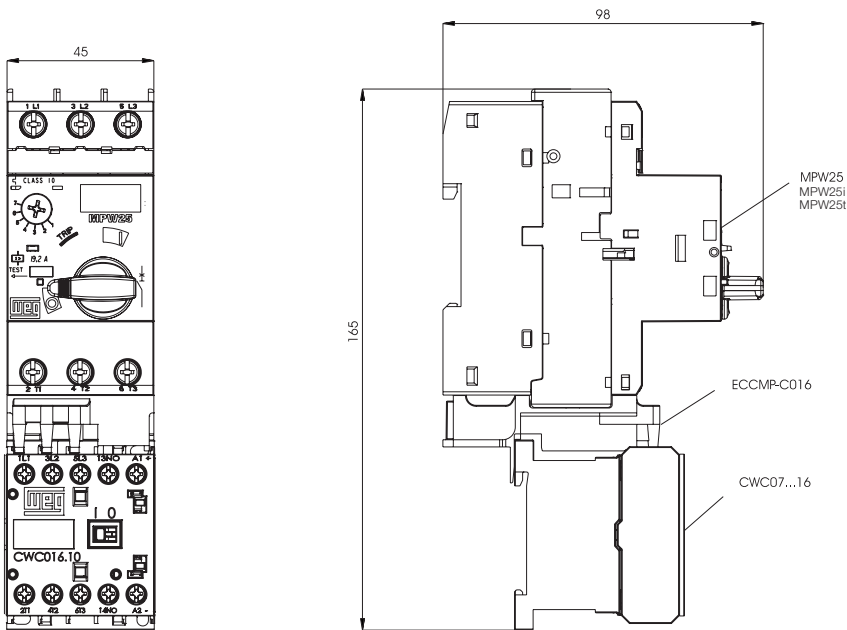

Motor Protective Circuit Breaker MPW - Dimensions (mm)

MPW25 + CWC025

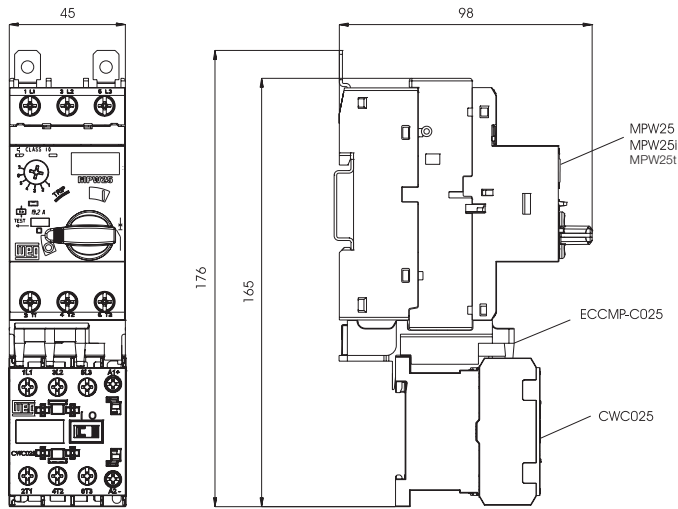

MPW25 + CWM9...18

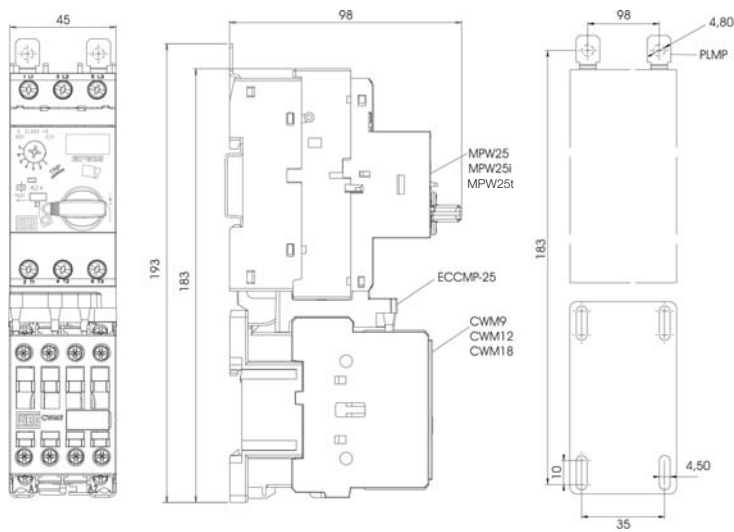

MPW25 + CWM25

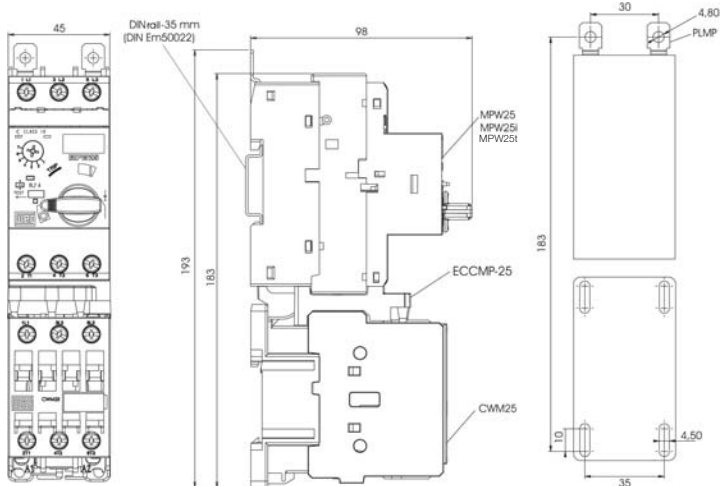

Motor Protective Circuit Breaker MPW - Dimensions (mm)

MPW25 + CWM32

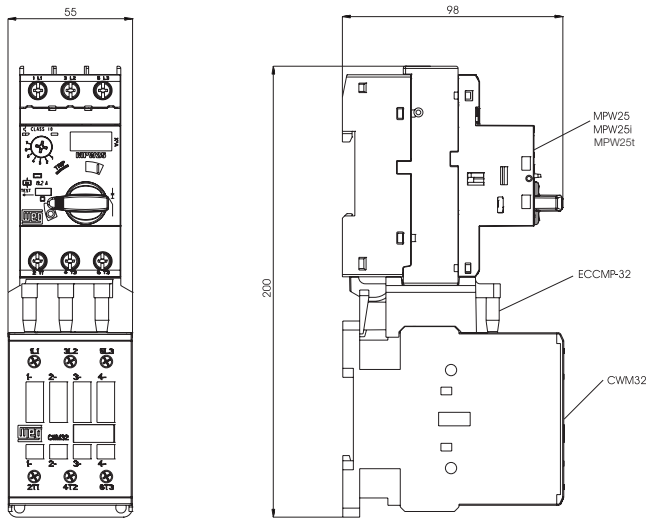

Current limiter - CLT25

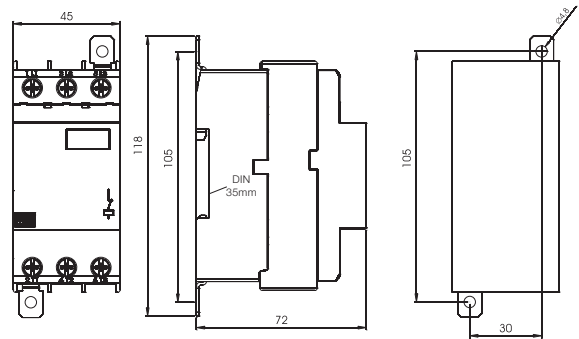

Front Plate - FME55

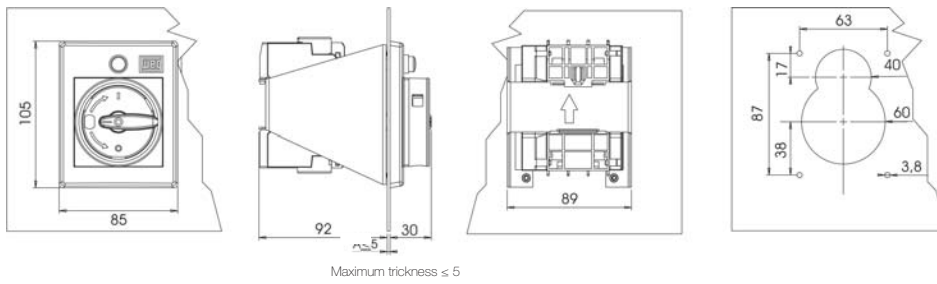

Insulated Enclosure - MPE55 (IP55)

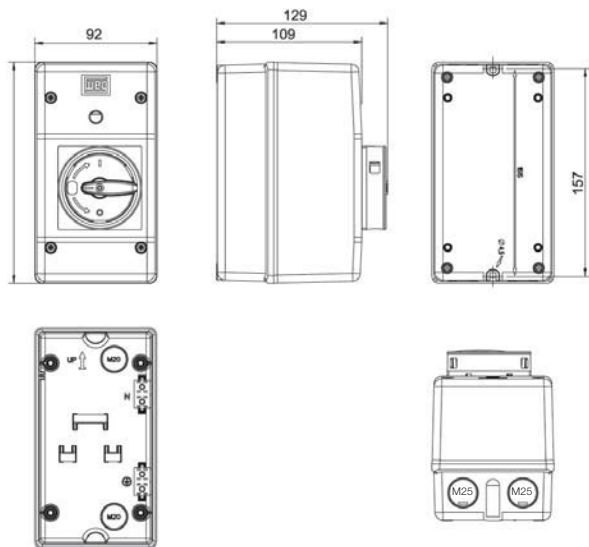

Insulated Enclosure - MLPE55 (IP55)

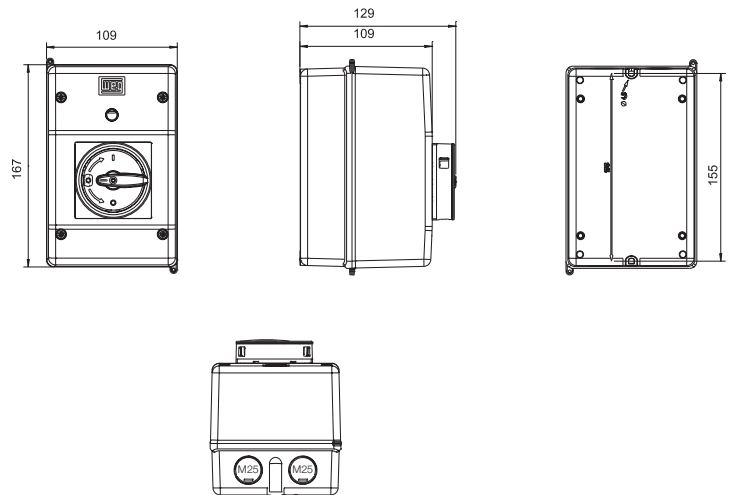

Motor Protective Circuit Breaker MPW - Dimensions (mm)

Accessories: BBS45, BBS54, FTBBS, LST25

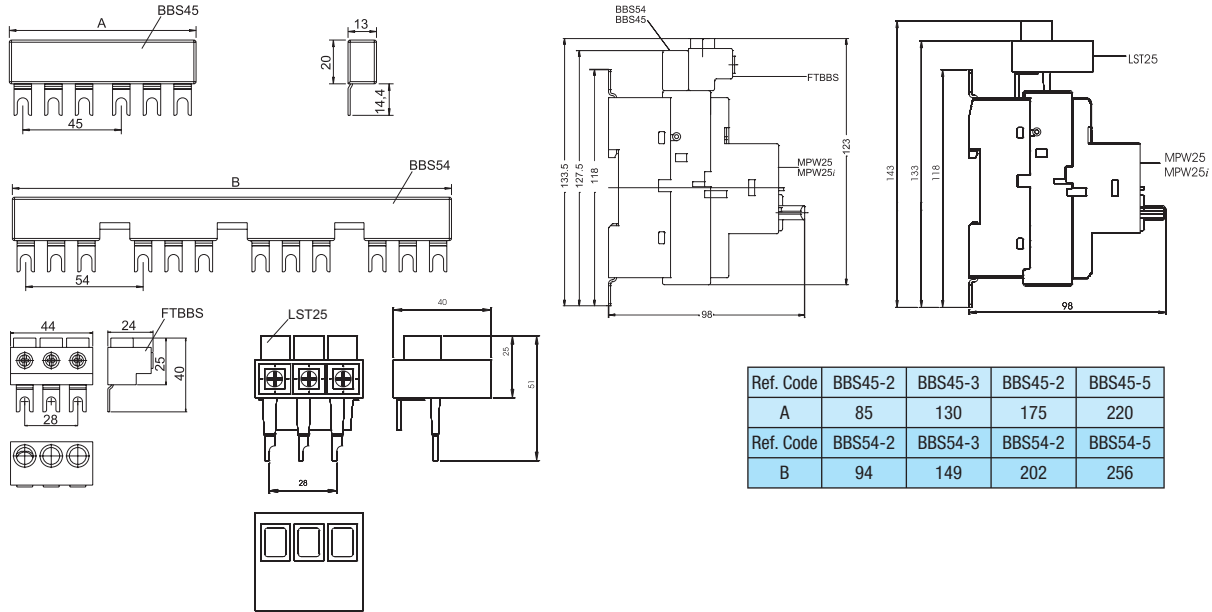

Door Coupling Rotary Handle - RMMP

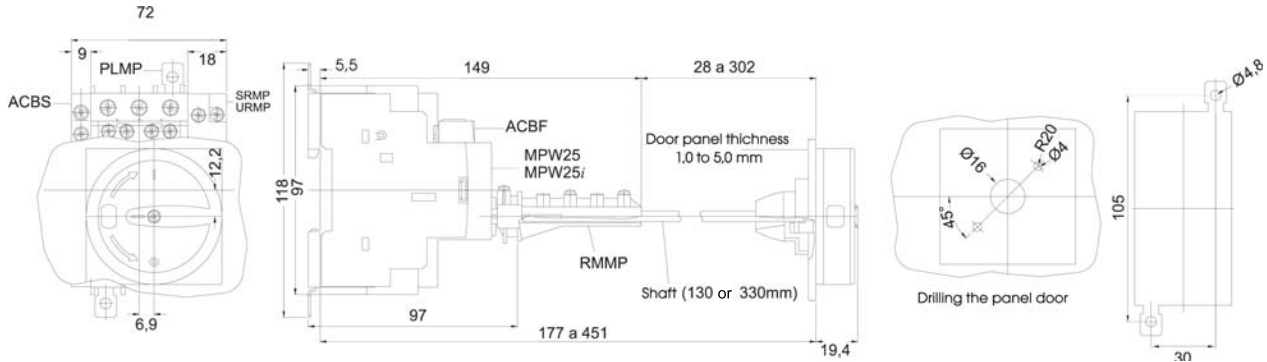

Door Coupling Rotary Handle - MR MPW25

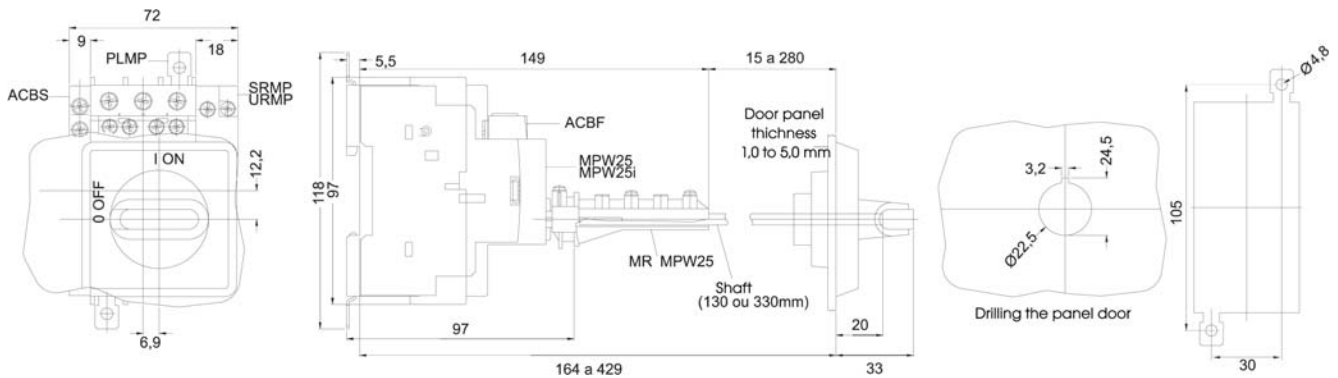

Motor Protective Circuit Breaker MPW - Dimensions (mm)

Door Coupling Rotary Handle - MRX

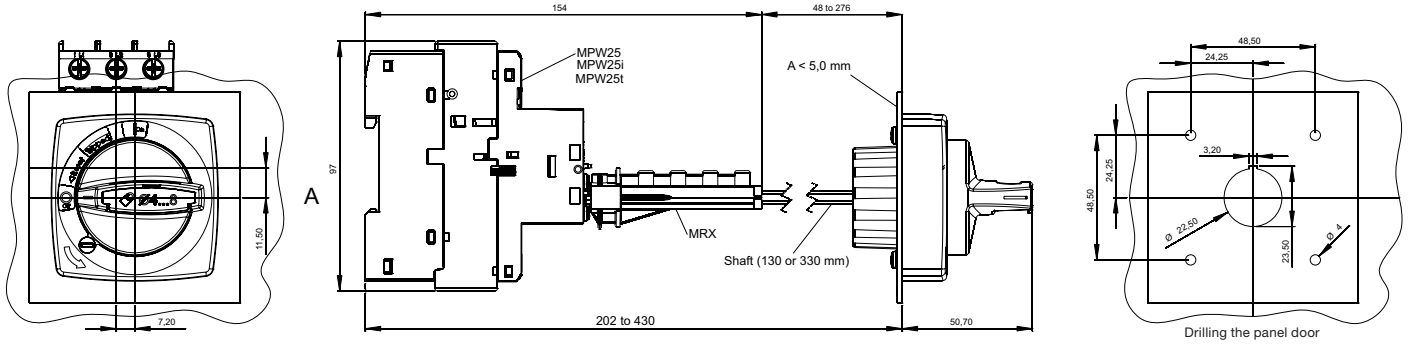

MPW65 + Accessories

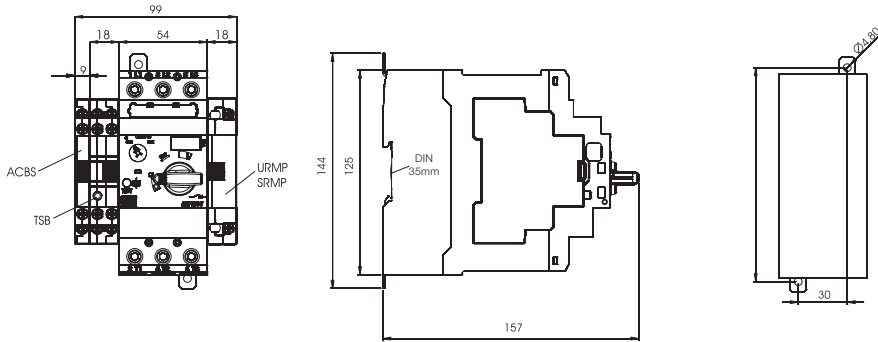

Mounting Position

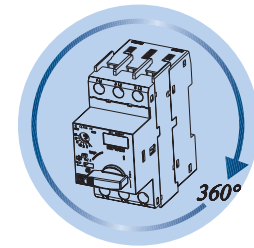

Door Coupling Rotary Handle - RMMP65

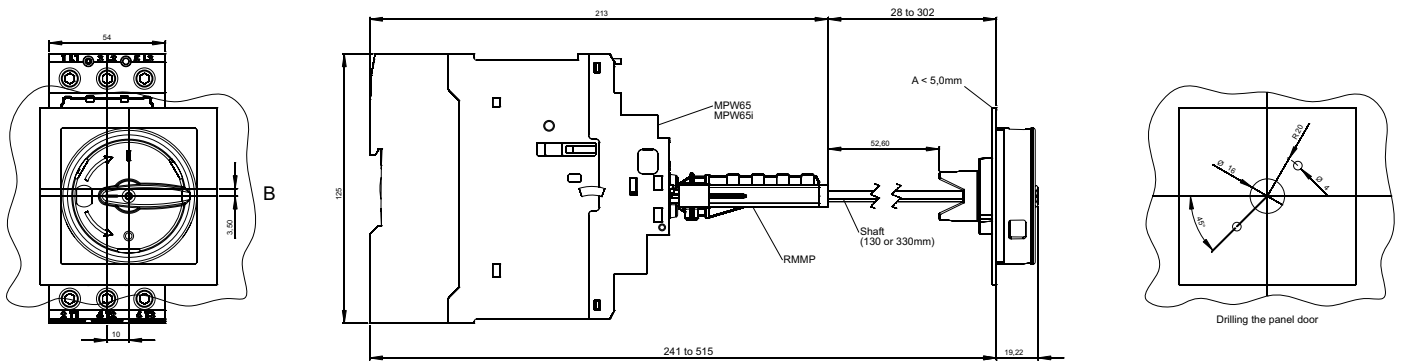

Door Coupling Rotary Handle - MRX65

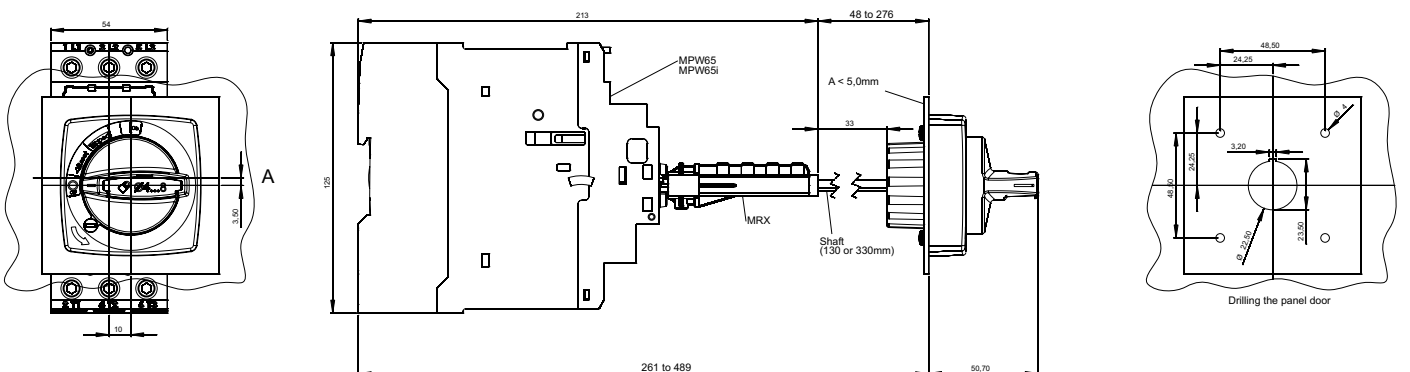

Motor Protective Circuit Breaker MPW - Dimensions (mm)

MPW100

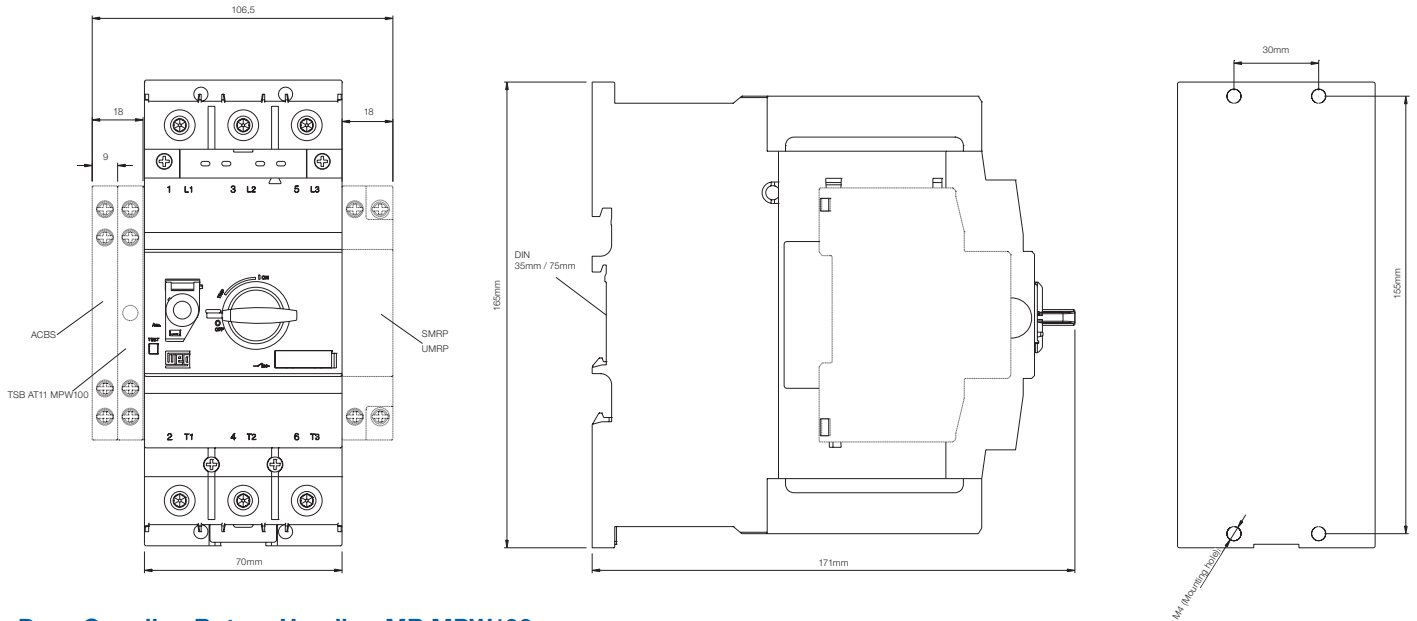

Door Coupling Rotary Handle - MR MPW100

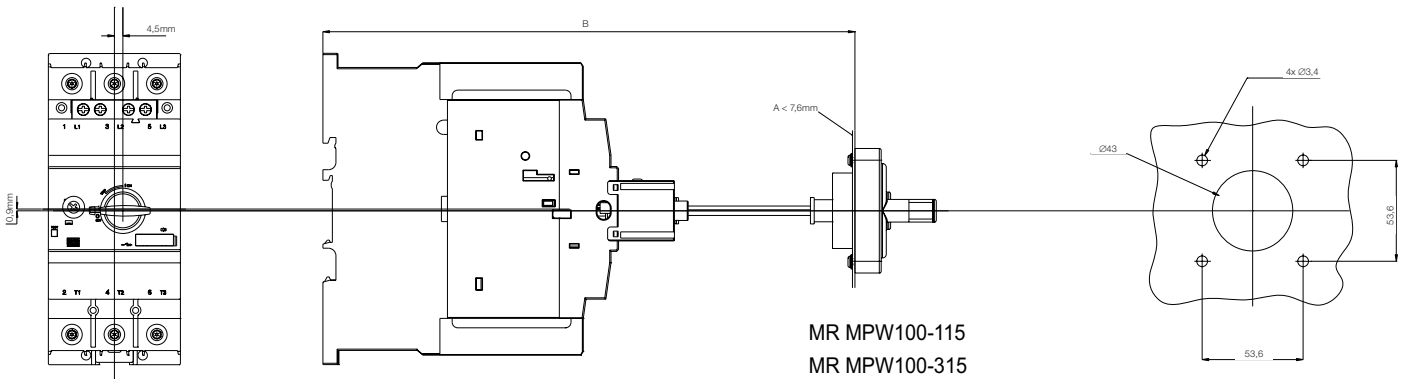

MR MPW100-115
MR MPW100-315

Reference Code	B (mm)
MR MPW100-115	min: 220
	max: 282
MR MPW100-315	min: 220
	max: 482

Drilling the panel door

Mounting position

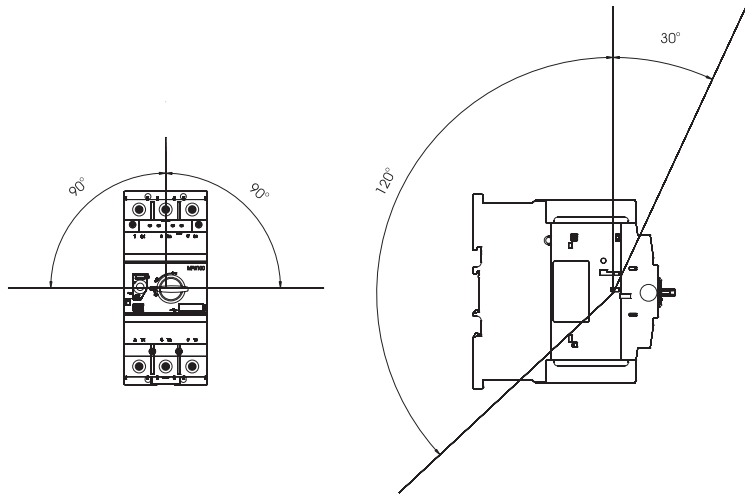

Enclosed and Open Starters

- Start/Stop contacts independent from main contactor and from thermal overload relay
- Allows cable connection from rear side of the enclosure
- Thermal overload relay reset integrated to the stop button
- D.O.L. Starters for electric motors up to 37kW@690V
- Enclosure IP65 - Totally insulated

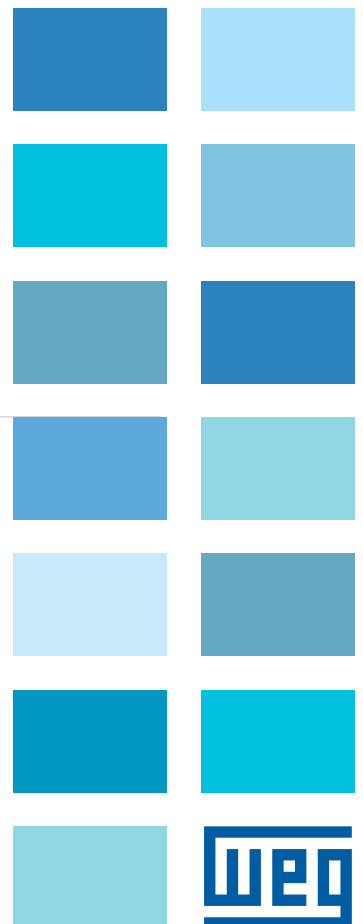

Enclosed Direct-on-Line Starter

Three-phase D.O.L Starter

- Assembled with thermal overload relay
- Short circuit protection has to be ensured by a separate short circuit protection facility
- IP65



Maximum rated operational power of three-phase motors 50/60 Hz ¹⁾				Setting range of overload relay  I _r (A)	Max. rated operational A	Reference Code	Contactor	Overload relay	Weight kg
230-240V kW	400-415V kW	500V kW	690V kW						
Enclosed Direct-On-Line Starters size 02									
0.06	0.09	-	-	0.28 ... 0.4	0.4	DLW-7■■■■P65-R01	CW07	RW17-1D3-D004	0.530
0.09	0.12	-	-	0.4 ... 0.63	0.63	DLW-7■■■■P65-R02	CW07	RW17-1D3-C063	
	0.18	-	-						
0.12	0.25	-	-	0.56 ... 0.8	0.8	DLW-7■■■■P65-R03	CW07	RW17-1D3-D008	
0.18	0.37	-	-	0.8 ... 1.2	1.2	DLW-7■■■■P65-R04	CW07	RW17-1D3-D012	
0.25	0.55	-	-	1.2 ... 1.8	1.8	DLW-7■■■■P65-R05	CW07	RW17-1D3-D018	
0.37	0.75	-	-	1.8 ... 1.8	2.8	DLW-7■■■■P65-R06	CW07	RW17-1D3-D028	
0.55	1.1	-	-						
0.75	1.5	-	-	2.8 ... 4.0	4.0	DLW-7■■■■P65-R07	CW07	RW17-1D3-U004	
1.1	2.2	-	-	4.0 ... 6.3	6.3	DLW-7■■■■P65-R08	CW07	RW17-1D3-D063	
1.5	3	-	-	5.6 ... 8.0	7.0	DLW-7■■■■P65-R09	CW07	RW17-1D3-U008	
Enclosed Direct-On-Line Starters size 04									
-	-	0.12	0.18	0.28 ... 0.4	0.4	DLW-9■■■■P65-R20	CWM9	RW27-1D3-D004	0.804
-	-	0.18	0.25	0.4 ... 0.63	0.63	DLW-9■■■■P65-R21	CWM9	RW27-1D3-C063	
-	-	0.25	0.37	0.56 ... 0.8	0.8	DLW-9■■■■P65-R22	CWM9	RW27-1D3-D008	
-	-	0.37	0.55	0.8 ... 1.2	1.2	DLW-9■■■■P65-R23	CWM9	RW27-1D3-D012	
-	-	0.55	0.75						
-	-	0.75	1.1	1.2 ... 1.8	1.8	DLW-9■■■■P65-R24	CWM9	RW27-1D3-D018	
-	-	1.1	1.5	1.8 ... 2.8	2.8	DLW-9■■■■P65-R25	CWM9	RW27-1D3-D028	
-	-	1.5	2.2						
-	-	2.2	3	2.8 ... 4.0	4.0	DLW-9■■■■P65-R26	CWM9	RW27-1D3-U004	
-	-	3	4	4.0 ... 6.3	6.3	DLW-9■■■■P65-R27	CWM9	RW27-1D3-D063	
-	-	4	5.5	5.6 ... 8.0	8.0	DLW-9■■■■P65-R28	CWM9	RW27-1D3-U008	
2.2	4	5.5	7.5	7.0 ... 10	9.0	DLW-9■■■■P65-R29	CWM9	RW27-1D3-U010	0.815
3.0	5.5	-	9.2	8.0 ... 12.5	12	DLW-12■■■■P65-R30	CWM12	RW27-1D3-D125	
-	-	7.5	11	10 ... 15	15	DLW-18■■■■P65-R31	CWM18	RW27-1D3-U015	
4.0	7.5	9.2	-	11 ... 17	67	DLW-18■■■■P65-R32	CWM18	RW27-1D3-U017	
-	9.2	11	15	15 ... 23	18	DLW-18■■■■P65-R33	CWM18	RW27-1D3-U023	0.860
5.5	11	-	18.5	15 ... 23	23	DLW-25■■■■P65-R34	CWM25	RW27-1D3-U023	
7.5	-	15	22	22 ... 32	25	DLW-25■■■■P65-R35	CWM25	RW27-1D3-U032	
Enclosed Direct-On-Line Starters size 06									
-	15	18.5	-	22 ... 32	32	DLW-32■■■■P65-R34	CWM32	RW27-1D3-U032	1.270
9.2	-	-	30	25 ... 40	32	DLW-32■■■■P65-R35	CWM32	RW67-1D3-U040	
11	18.5	22	-	25 ... 40	40	DLW-40■■■■P65-R35	CWM40	RW67-1D3-U040	1.430
-	-	-	37	32 ... 50	40	DLW-40■■■■P65-R37	CWM40	RW67-1D3-U050	

Replace by code for control voltage

Replace by version suffix code (device)

Control voltage 50/60Hz ²⁾	230V	240V	400V	415V	500V
Codes	D24	D25	D34	D35	D40

Versions (add suffix code in type)	
Device	Code
Start - Stop/Reset operation (standard)	P
Remote control (without buttons)	I
Stop/Reset operation (without ON button)	D
Hand/OFF/Auto operation (Hand = local control / Auto = remote control)	B

Notes: 1) Some motors characteristics may vary according to each manufacturer.
 2) Other voltages available.
 3) Spare mini contactor for DLW-7 on request.

Enclosed Direct-on-Line Starter

Single phase D.O.L Starter

- Assembled with thermal overload relay
- Short circuit protection has to be ensured by a separate short circuit protection facility
- IP65



Maximum rated operational power of three-phase motors 50/60 Hz ¹⁾		Setting range of overload relay  Ir (A)	Max. rated operational A	Reference Code	Contactor	Overload relay	Weight kg
230/240V kW							
Enclosed Direct-On-Line Starters size 02							
0,25		1,8 ... 2,8	7	DLWM-7■■■■P65-RM06	CW07	RW17-1D2-D028	0,530
0,37		2,8 ... 4	7	DLWM-7■■■■P65-RM07	CW07	RW17-1D2-U004	
0,55-0,75		4 ... 6,3	7	DLWM-7■■■■P65-RM08	CW07	RW17-1D2-D063	
1,1		5,6 ... 8	7	DLWM-7■■■■P65-RM09	CW07	RW17-1D2-U008	

Maximum rated operational power of three-phase motors 50/60 Hz ¹⁾		Setting range of overload relay  Ir (A)	Max. rated operational A	Reference Code	Contactor	Overload relay	Weight kg
230/240V	480V						
Enclosed Direct-On-Line Starters size 04							
-	0,25	0,8 ... 1,2	9	DLWM-9■■■■P65-RM23	CWM9	RW27-1D2-D012	0,804
-	0,37	1,2 ... 1,8	9	DLWM-9■■■■P65-RM24	CWM9	RW27-1D2-D018	
-	0,55-0,75	1,8 ... 2,8	9	DLWM-9■■■■P65-RM25	CWM9	RW27-1D2-D028	
-	1,1	2,8 ... 4	9	DLWM-9■■■■P65-RM26	CWM9	RW27-1D2-U004	
-	1,5	4 ... 6,3	9	DLWM-9■■■■P65-RM27	CWM9	RW27-1D2-D063	
-	2,2	5,6 ... 8	9	DLWM-9■■■■P65-RM28	CWM9	RW27-1D2-U008	
-	3	7 ... 10	9	DLWM-9■■■■P65-RM29	CWM9	RW27-1D2-U010	0,815
1,5	3,7	8 ... 12,5	12	DLWM-12■■■■P65-RM30	CWM12	RW27-1D2-D125	
2,2	-	10 ... 15	18	DLWM-18■■■■P65-RM31	CWM18	RW27-1D2-U015	0,815
-	-	11 ... 17	18	DLWM-18■■■■P65-RM32	CWM18	RW27-1D2-U017	
3	-	15 ... 23	18	DLWM-18■■■■P65-RM33	CWM18	RW27-1D2-U023	0,860
-	5,5	11 ... 17	25	DLWM-25■■■■P65-RM32	CWM25	RW27-1D2-U017	
3,7	-	15 ... 23	25	DLWM-25■■■■P65-RM33	CWM25	RW27-1D2-U023	
-	-	22 ... 32	25	DLWM-25■■■■P65-RM34	CWM25	RW27-1D2-U032	
Enclosed Direct-On-Line Starters size 06							
-	7,5	15 ... 23	32	DLWM-32■■■■P65-RM33	CWM32	RW27-1D2-U023	1,270
7,5	-	25 ... 40	32	DLWM-32■■■■P65-RM35	CWM32	RW67-1D2-U040	
10	-	30 ... 50	40	DLWM-40■■■■P65-RM37	CWM40	RW67-1D2-U050	1,430

Replace by code for control voltage

Control voltage 50/60Hz ²⁾	230V	240V	400V	415V	500V
Codes	D24	D25	D34	D35	D40

Replace by version suffix code (device)



Versions (add suffix code in type)	
Device	Code
Start - Stop/Reset operation (standard)	P
Remote control (without buttons)	I
Stop/Reset operation (without ON button)	D
Hand/OFF/Auto operation (Hand = local control / Auto = remote control)	B

Notes: 1) Some motors characteristics may vary according to each manufacturer.
 2) Other voltages available.
 3) Spare mini contactor for DLW-7 on request.

Enclosed Direct-on-Line Starter - Accessories

Empty Enclosures

- IP65
- For housing one CWC07...16, CWM9...40 contactor and one RW overload relay

Illustrative pictures	Size	Reference Code	For use with	Weight kg
Empty enclosure. with ON/OFF operation 	02	EB 02P	CW07 + RW17	0.200
	04	EB 04P	CWM9...25 + RW27	0.275
	04	EB 04CP	CWC07...16 + RW17	0.275
	06	EB 06AP	CWM32 + RW27	0.390
	06	EB 06BP	CWM32...40 + RW67-1D	0.390
Empty enclosure. with STOP/RESET operation 	02	EB 02D	CW07 + RW17	0.200
	04	EB 04D	CWM9...25 + RW27	0.275
	04	EB 04CD	CWC07...16 + RW17	0.275
	06	EB 06AD	CWM32 + RW27	0.390
	06	EB 06BD	CWM32...40 + RW67-1D	0.390
Empty enclosure. with HAND/OFF/AUTO operation 	02	EB 02B	CW07 + RW17	0.210
	04	EB 04B	CWM9...25 + RW27	0.285
	04	EB 04CB	CWC07...16 + RW17	0.285
	06	EB 06AB	CWM32 + RW27	0.400
	06	EB 06BB	CWM32...40 + RW67-1D	0.400

Wiring Diagram

Three phase D.O.L. Starter

Single-phase D.O.L Starter

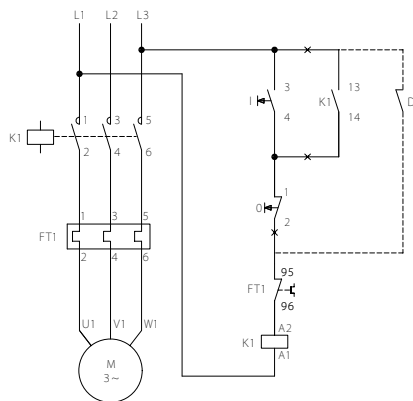

Figure 1

Control circuit with phase to phase coil supply

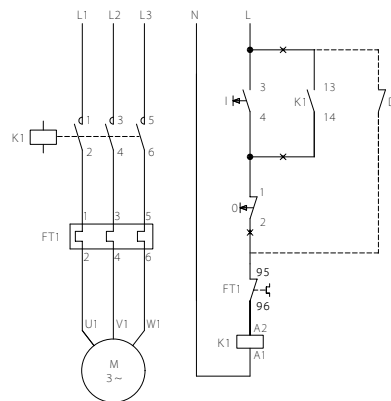
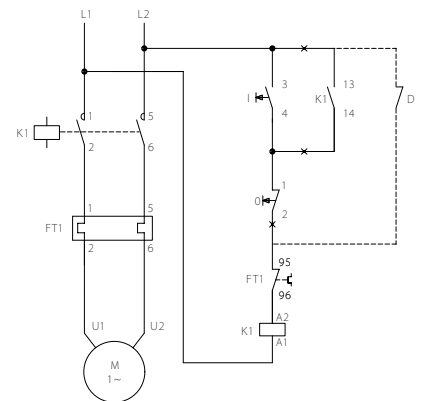

Figure 2

Control circuit with separate coil supply



When using 230V, 400V, 500V, and 690V on the reference code, WEG D.O.L. starters (DLW) will be factory-connected, as per wiring diagrams of figure 1, that is, with phase to phase coil supply. For the voltages with phase to phase coil supply, contact WEG.

When using 24V, 48V, 110V, etc. on the reference code, WEG D.O.L. starters (DLW) will be factory-connected, as per wiring diagrams of figure 2, that is, with control circuit to be connected through a separate coil supply.

Note: When using remote control, disconnect the circuit at the points marked with the "x" in figures 1 and 2 and connect the external devices (Thermostat, pushbutton, etc), as indicated with dotted lines.

Enclosed Direct-on-Line Starter - Technical Data

Enclosed Direct-on-Line Starters DLW / DLWM - Dimensions (mm)

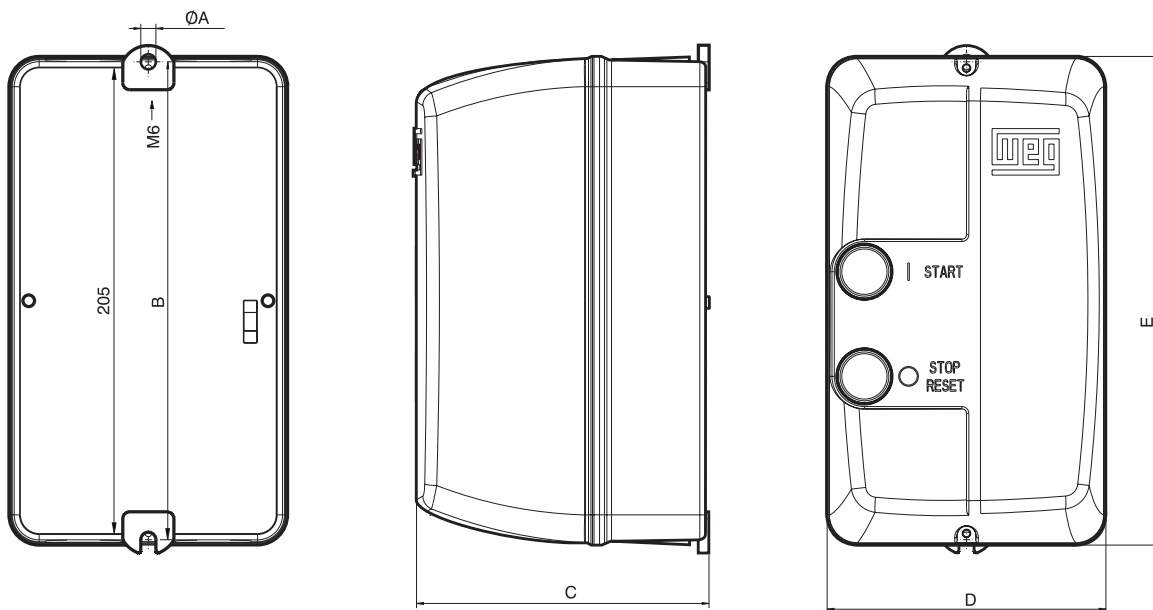

Size	02	04	06
$\varnothing A$	4.5	4.5	6.5
B	150	180	205
C	98	111	126
D	90	105	120
E	155	185	210

Size	02	04	06
top	4.5	4.5	6.5
bottom	150	180	205
back	98	111	126

Standard	IEC/EN 60947
Operating temperature	-20°C...55°C
Storage temperature	-50°C...80°C
Degree of protection	IP65
Mechanical lifespan (operation)	1 x 10 ⁶
Electrical lifespan (operation)	1 x 10 ⁵
Maximum number of operation per hour	15

Enclosed Star-Delta Starter

- Start and Stop pushbuttons using CSW line
- Degree of protection IP65
- RTW – ET electronic timer with adjustable change over time (3 to 30 seconds)
- Standard thermal overload RW, phase-failure sensitivity, tripping class 10, temperature compensation, auxiliary contacts and Hand/Auto/Reset button
- Ample wiring space

Selection guide

Size 10

Maximum rated operational power of three-phase motors 50/60 Hz ¹⁾	Main & Delta Contactors	Star Contactor	Overload relay	Reference Code	
				Control Voltage ²⁾	
				240VAC – 50/60Hz	415VAC – 50/60Hz
3...7.5	CWM9	CWM9	RW27	ESDW-7.5D25A65	ESDW-7.5D35A65
11	CWM12	CWM9	RW27	ESDW-11D25A65	ESDW-11D35A65
15	CWM18	CWM12	RW27	ESDW-15D25A65	ESDW-15D35A65
18.5	CWM25	CWM12	RW27	ESDW-18.5D25A65	ESDW-18.5D35A65
22	CWM25	CWM18	RW27	ESDW-22D25A65	ESDW-22D35A65
30	CWM40	CWM18	RW67	ESDW-30D25A65	ESDW-30D35A65
37	CWM40	CWM25	RW67	ESDW-37D25A65	ESDW-37D35A65
45	CWM50	CWM32	RW67	ESDW-45D25A65	ESDW-45D35A65
55	CWM65	CWM32	RW67	ESDW-55D25A65	ESDW-55D35A65
75	CWM80	CWM50	RW67	ESDW-75D25A65	ESDW-75D35A65

WEG can build special starters according to your requirements. Contact your local WEG Office or Agent.

Dimensions

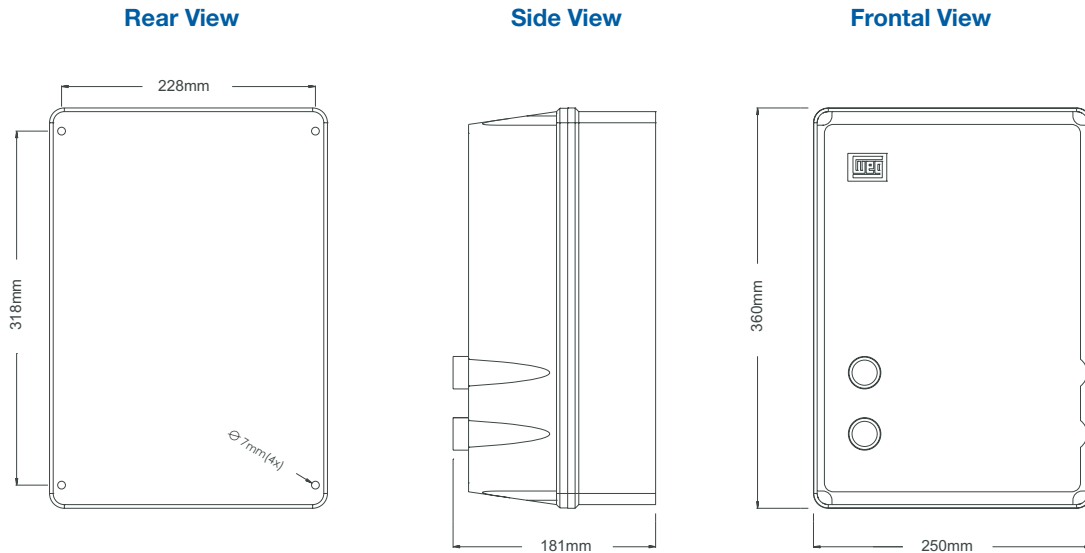

Provision for cable	STANDARD	
	Top	Bottom
Size 10	3 x $\varnothing 28.3\text{mm}$ or 3 x $\varnothing 37\text{mm}$	3 x $\varnothing 28.3\text{mm}$ or 3 x $\varnothing 37\text{mm}$

Notes: 1) Specifications valid only for 50/60Hz three phase, 4 poles WEG standard motors. These values are only for reference and may change on the number of poles and motor design;
2) For contactor coil voltage different to the supply voltage, contact WEG.

Open Star-Delta Starter

- Standard thermal overload RW, phase-failure sensitivity, tripping class 10, temperature compensation, auxiliary contacts and Hand/Auto/Reset button
- Terminal blocks for start and stop pushbuttons connections
- Easy installation
- RTW – ET electronic timer with adjustable change over time (3 to 30 seconds)

Selection guide

Maximum rated operational power of three-phase motors 50/60 Hz ¹⁾	Main & Delta Contactors	Star Contactors	Overload relay	Reference Code	
				Control Voltage ²⁾	
				240VAC – 50/60Hz	415VAC – 50/60Hz
3...7.5	CWM9	CWM9	RW27	OSDW-7.5D25A	OSDW-7.5D35A
11	CWM12	CWM9	RW27	OSDW-11D25A	OSDW-11D35A
15	CWM18	CWM12	RW27	OSDW-15D25A	OSDW-15D35A
18.5	CWM25	CWM12	RW27	OSDW-18.5D25A	OSDW-18.5D35A
22	CWM25	CWM18	RW27	OSDW-22D25A	OSDW-22D35A
30	CWM40	CWM18	RW67	OSDW-30D25A	OSDW-30D35A
37	CWM40	CWM25	RW67	OSDW-37D25A	OSDW-37D35A
45	CWM50	CWM32	RW67	OSDW-45D25A	OSDW-45D35A
55	CWM65	CWM32	RW67	OSDW-55D25A	OSDW-55D35A
75	CWM80	CWM50	RW67	OSDW-75D25A	OSDW-75D35A

Dimensions

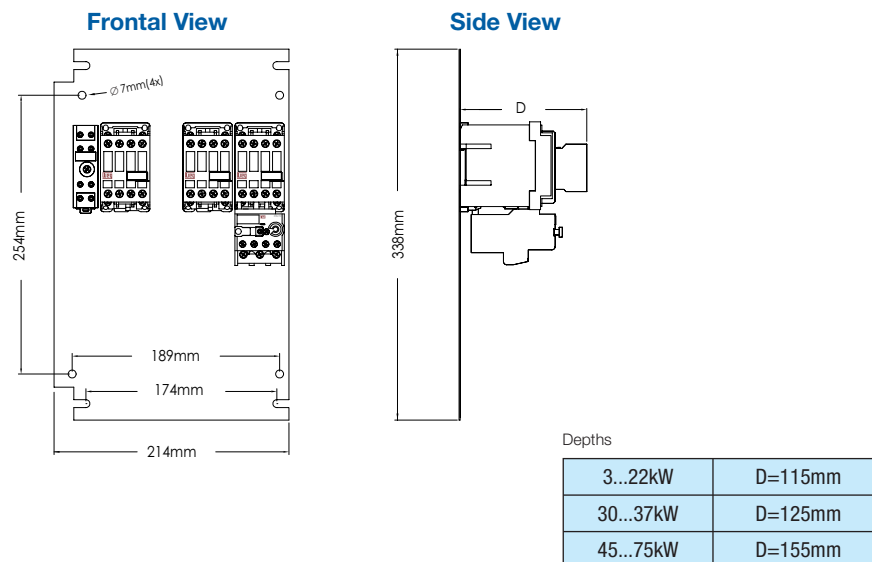

Notes: 1) Specifications valid only for 50/60Hz three phase, 4 poles WEG standard motors. These values are only for reference and may change on the number of poles and motor design;
 2) For contactor coil voltage different to the supply voltage, contact WEG.

Pushbutton and Pilot Lights

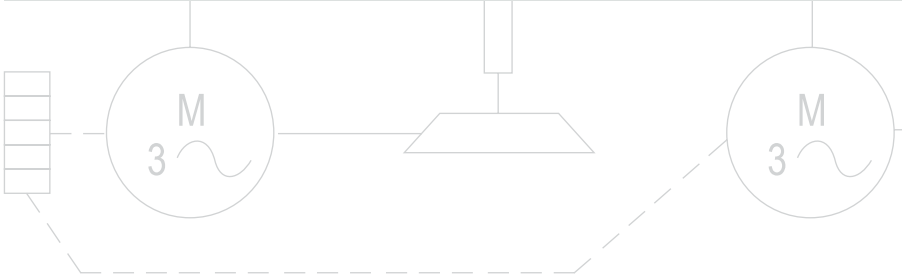
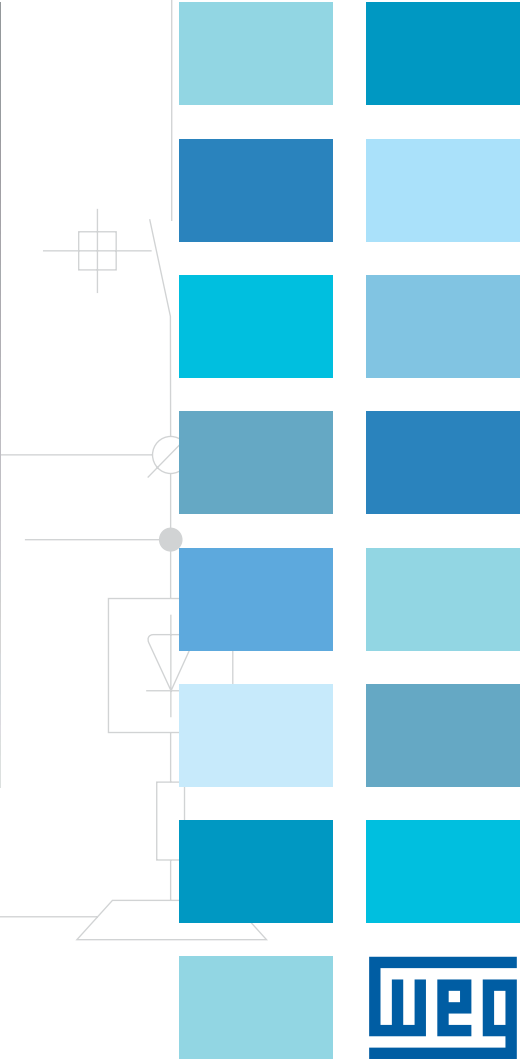
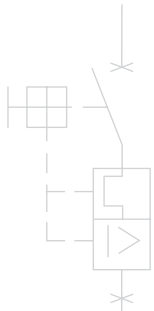

Pushbuttons and Pilot Lights - CSW Series (Ø 22mm)

Nº	Description
1	Double Pushbutton
2	Protection Cover for Double Pushbutton
3	Illuminated Flush Pushbutton
4	Flush Pushbutton
5	Protection Cover for Flush Pushbutton
6	Selector Switch Knob
7	Selector Switch Lever
8	Illuminated Selector Switch
9	Key Switch
10	Pilot Light
11	Mushroom Pushbutton
12	Emergency-Stop Pushbutton - Twist Release
13	Emergency-Stop Pushbutton - Key Release
14	Plate Holder
15	Legend Plate
16	Double Contact Block
17	LED Block
18	Contact Block - NO or NC
19	Contact Block NCdb (delayed break)
20	Push-On / Push-Off Block
21	Contact Block NOem (early make)
22	Flange - 3 Positions
23	Flange - 5 Positions
24	Illuminated Extended Pushbutton
25	Illuninated Mushroom Pushbutton
26	Guarded Pushbutton
27	Protection Cover for BFI and BSI Pushbuttons
28	Plate Holder for Double Pushbutton
29	Emergency Pushbutton Protection
30	Emergency-Stop Pushbutton BESG - Twist Release
31	Emergency-Stop Pushbutton BESP - Pull Release
32	Emergency-Stop Pushbutton BESY - Key Release

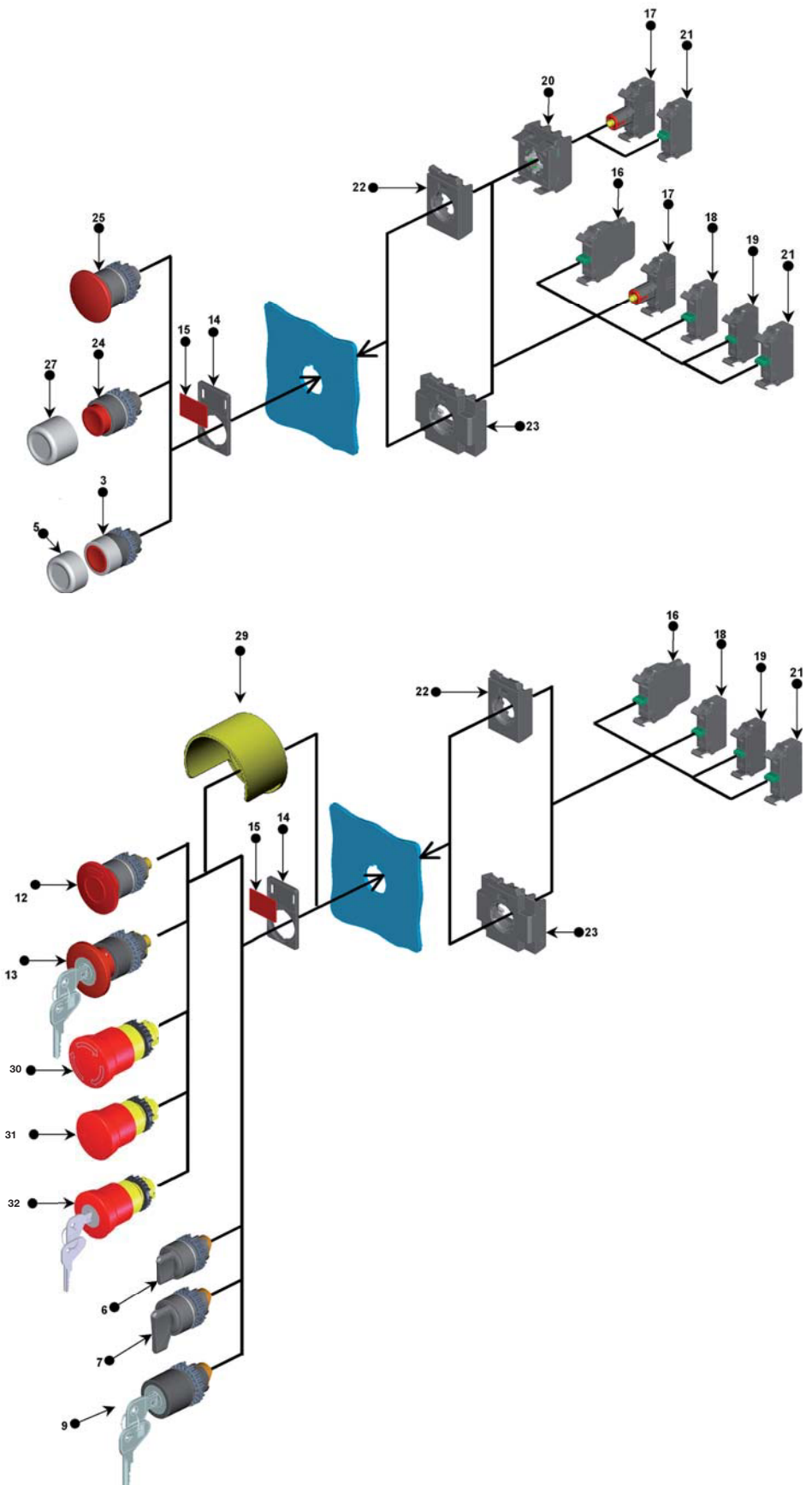

IP66



Totally Insulated

Certifications



Pushbuttons and Pilot Lights - CSW Series (Ø 22mm)

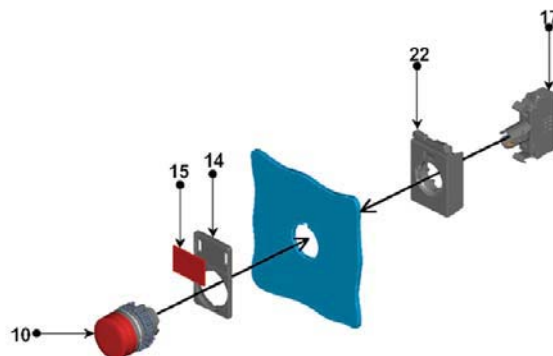
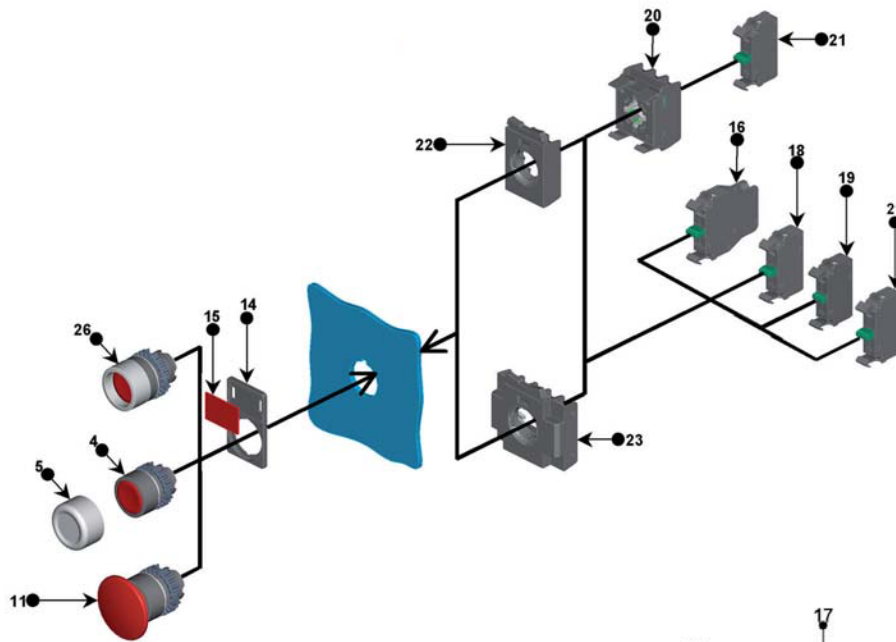
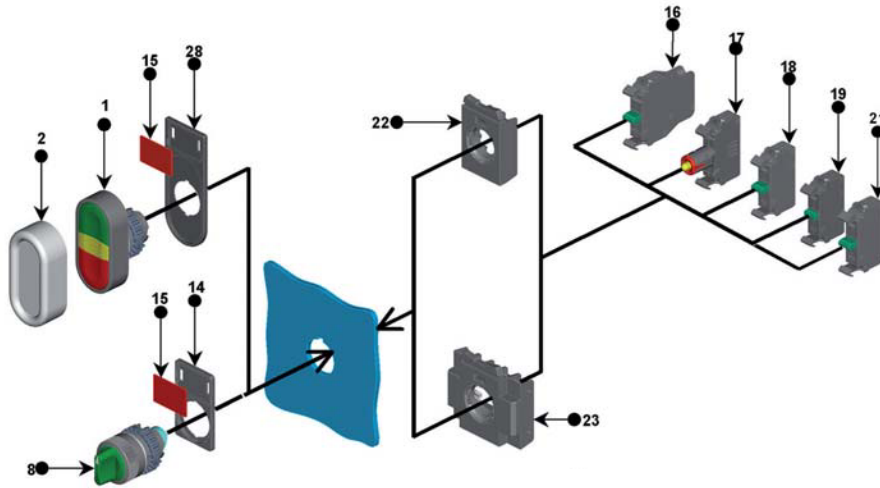

Pushbuttons and Pilot Lights - CSW Series (Ø 22mm)





Pushbuttons Reference Code Composition



Types

- F - Flush
- GA - Guarded
- C - Mushroom
- D - Double
- FI - Illuminated flush
- SI - Illuminated extended
- CI - Illuminated mushroom

CSW-B _ _

Color (See color code)

Flush	Guarded	Mushroom (Ø40 mm)	Double ¹⁾²⁾
<ul style="list-style-type: none"> ○ BF0 ● BF1 ● BF2 ● BF3 ● BF4 ● BF5 	<ul style="list-style-type: none"> ○ BGA0 ● BGA1 ● BGA2 ● BGA3 ● BGA4 ● BGA5 	<ul style="list-style-type: none"> ● BC1 ● BC2  <p>Other colors on request</p>	<p>BD (IP40)</p>  <p>Central lens can be illuminated with LED block</p>

Illuminated Flush ¹⁾	Illuminated Extended ¹⁾	Illuminated Mushroom (Ø40 mm) ¹⁾
<ul style="list-style-type: none"> ○ BFI0 ● BFI1 ● BFI2 ● BFI3 ● BFI4 	<ul style="list-style-type: none"> ○ BSI0 ● BSI1 ● BSI2 ● BSI3 ● BSI4 	<ul style="list-style-type: none"> ○ BCI0 ● BCI1 ● BCI2 ● BCI3 ● BCI4 

Color Code

Color	Clear/White	Red	Green	Yellow	Blue	Black
Code	0	1	2	3	4	5
Symbol	○	●	●	●	●	●

Notes: 1) Contact block not allowed to be used in the control position of the flange.
2) To increase the degree of protection, use APBD protection.

Pushbuttons and Pilot Lights - CSW Series (Ø 22mm)

Emergency Pushbuttons Reference Code Composition (With lock)

CSW-B — Types
 G - Twist to Release
 P - Pull to Release (Only BES)
 Y - Key to Release





Types
 E - Mushroom
 ES - Safe (EN418 and IEC60947-5-5)

E-Stop - Twist to Release	E-Stop - Pull to Release	E-Stop - Stop Pushbutton BESY - Key to Release ¹⁾
 <p>BESG</p> <p>EN418 IEC60947-5-5</p>	 <p>BESP</p> <p>EN418 IEC60947-5-5</p>	 <p>BESY</p> <p>EN418 IEC60947-5-5</p>

E-Stop - Twist to Release	E-Stop - Key to Release ¹⁾
 <p>BEG</p>	 <p>BEY</p>







Pilot Lights Reference Code Composition

CSW-SD —
 Color (See color code)

Pilot light	
	SD0
	SD1
	SD2
	SD3
	SD4



Color Code

Color	Clear/White	Red	Green	Yellow	Blue	Black
Code	0	1	2	3	4	5
Symbol						

Note: 1) For different key codes on request

Pushbuttons and Pilot Lights - CSW Series (Ø 22mm)

Selector Switches Reference Code Composition

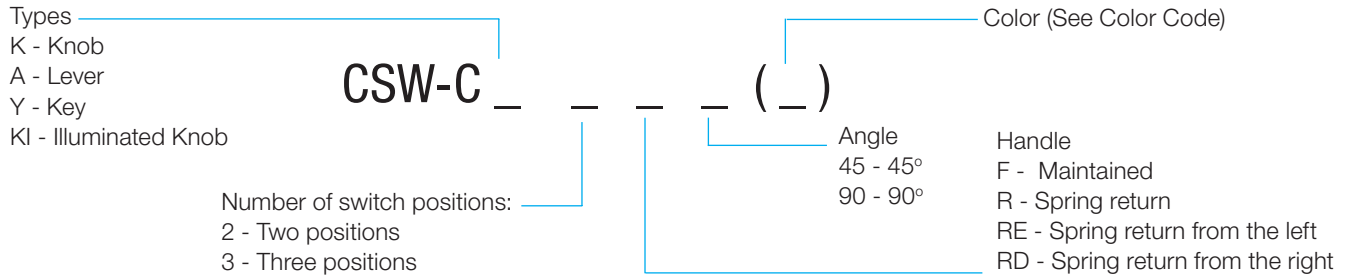

Knob	Lever	Key ¹⁾²⁾	Illuminated	Position	Diagram
CK2F45	CA2F45	CY2F45	-		1
CK2R45	CA2R45	CY2R45	-		1
CK2F90	CA2F90	CY2F90	CKI2F90(_)		2
CK2R90	CA2R90	CY2R90	-		2
CK3F45	CA3F45	CY3F45	CKI3F45(_)		3
CK3R45	CA3R45	CY3R45	CKI3R45(_)		3
CK3RE45	CA3RE45	CY3RE45	CKI3RE45(_)		3
CK3RD45	CA3RD45	CY3RD45	CKI3RD45(_)		3
CK3F45ZB	CA3F45ZB	CY3F45ZB	-		4
CK3R45ZB	CA3R45ZB	CY3R45ZB	-		4
CK3F45U	CA3F45U	CY3F45U	-		5
CK3R45U	CA3R45U	CY3R45U	-		5

Diagram 1				Diagram 2					
	Handle position	Mounting position in flange				Handle position	Mounting position in flange		
		2	3	1			2	3	1
0	0	<input type="checkbox"/>	-	<input type="checkbox"/>	I	<input type="checkbox"/>	<input type="checkbox"/>	<input type="checkbox"/>	
I	I	<input checked="" type="checkbox"/>	-	<input checked="" type="checkbox"/>	II	<input checked="" type="checkbox"/>	<input checked="" type="checkbox"/>	<input checked="" type="checkbox"/>	

- Contacts in the rest position.
- Contacts operated.
- Contact block is operating at half stroke, position that keeps both NO and NC contacts OPEN.

Diagram 3				Diagram 4				Diagram 5						
	Handle position	Mounting position in flange				Handle position	Mounting position in flange				Handle position	Mounting position in flange		
		2	3	1			2	3	1			2	3	1
0	0	<input type="checkbox"/>	-	<input type="checkbox"/>	0	<input type="checkbox"/>	<input type="checkbox"/>	<input type="checkbox"/>	0	<input checked="" type="checkbox"/>	<input type="checkbox"/>	<input type="checkbox"/>		
I	I	<input checked="" type="checkbox"/>	-	<input type="checkbox"/>	I	<input checked="" type="checkbox"/>	<input checked="" type="checkbox"/>	<input checked="" type="checkbox"/>	I	<input type="checkbox"/>	<input checked="" type="checkbox"/>	<input checked="" type="checkbox"/>		
II	II	<input type="checkbox"/>	-	<input checked="" type="checkbox"/>	II	<input checked="" type="checkbox"/>	<input checked="" type="checkbox"/>	<input checked="" type="checkbox"/>	II	<input checked="" type="checkbox"/>	<input checked="" type="checkbox"/>	<input checked="" type="checkbox"/>		

- Mounting position for LED blocks in illuminated switches.

Notes: 1) For different key code on request
 2) Key released on in any position. For other options replace: - CY for CYD for key released only from right - CY for CYE for key released only from left - CY for CYC for key released on only from center.

Pushbuttons and Pilot Lights - CSW Series (Ø 22mm) - Accessories

Contact Blocks code composition

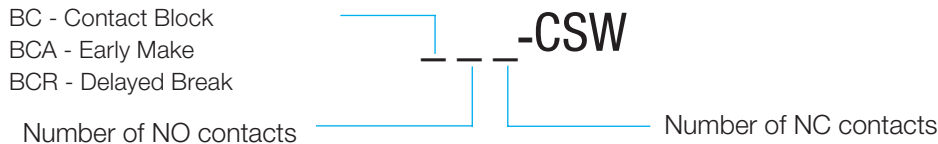

Single	Double
BC01 - 1NC BC10 - 1NO BCA10 - 1NO (early make) BCR01 - 1NC (delayed break)	BC11 - 1NO + 1NC BC20 - 2NO BC02 - 2NC

Lamp Blocks

CSW-BID	CSW-BIRD-D66
- For lamps with BA9s socket - Maximum voltage 380V (2W) - Lamp not included - VAC/DC	- This block (resistor + diode) allows use in 220-240VAC - Incandescent lamp included - Ba9s socket - 130V

Push-On / Push-Off Block

BR-3P-CSW
- For BF, BGA, BC, BFI, BSI and BCI pushbuttons Note: Only used with single contacts. For NO contact use BCA10 type (early make).

Lamps

Incandescent (Ba9s)	
L6VI-E48-0.6W	6 VAC/DC
L12VI-E25-1.8W	12 VAC/DC
L24VI-E26-2W	24 VAC/DC
L48VI-E27-2W	48 VAC/DC
L60VI-E28-1,2W	60 VAC/DC
L130VI-E30-2W	130 VAC/DC
L220VI-E31-2W	220 VAC/DC (Neon)

LED Blocks

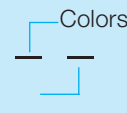
CSW-BIDL	
CSW-BIDL - Colors	
Voltage Code 12VAC/DC E25 24VAC/DC E26 48VAC/DC E27 110-130VAC D61 125VDC C13 220-240VAC D66	○ 0 Clear / White ● 1 Red ● 2 Green ● 3 Yellow ● 4 Blue
For 220VDC or 380-460VAC voltages, use BRT block	

Voltage Reducer Blocks

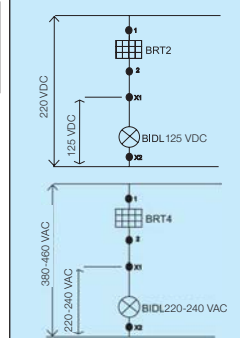
BRT blocks							
<table border="1"> <thead> <tr> <th>Ue</th> <th>Composition</th> </tr> </thead> <tbody> <tr> <td>220VDC</td> <td>BRT2+BIDL - C13(125VDC)</td> </tr> <tr> <td>380-460VAC</td> <td>BRT4+BIDL - D66(220-240VAC)</td> </tr> </tbody> </table>	Ue	Composition	220VDC	BRT2+BIDL - C13(125VDC)	380-460VAC	BRT4+BIDL - D66(220-240VAC)	
Ue	Composition						
220VDC	BRT2+BIDL - C13(125VDC)						
380-460VAC	BRT4+BIDL - D66(220-240VAC)						

Pushbuttons and Pilot Lights - CSW Series (Ø 22mm) - Accessories

Engraved Caps for Flush Pushbutton

Symbol	Cap Flush Pushbutton	Illuminated Pushbuttons (Lens)
⊘ Stop	ACB30	ALBI30
ⓘ Start	ACB31	ALBI31
↔ Rectilinear Movement	ACB32	ALBI32
⌚ Clockwise rotation	ACB33	ALBI33
⌚ Counterclockwise rotation	ACB34	ALBI34
Ⓜ Feed	ACB35	ALBI35

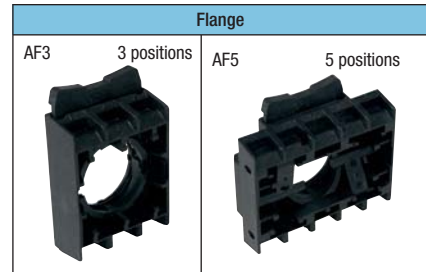



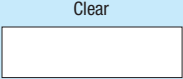







Plate Holder + Legend Plate ¹⁾								
<p>Black and Red</p>  <p>(27 x 18 mm) plate included</p>	<table border="1"> <thead> <tr> <th colspan="2">Type</th> </tr> </thead> <tbody> <tr> <td>Single</td> <td>Double (BD)</td> </tr> <tr> <td>APP30</td> <td>APP60</td> </tr> </tbody> </table>	Type		Single	Double (BD)	APP30	APP60	
Type								
Single	Double (BD)							
APP30	APP60							
<p>Clear</p>  <p>(27 x 18 mm) plate included</p>	<table border="1"> <thead> <tr> <th colspan="2">Type</th> </tr> </thead> <tbody> <tr> <td>Single</td> <td>Double (BD)</td> </tr> <tr> <td>APP30T</td> <td>APP60T</td> </tr> </tbody> </table>	Type		Single	Double (BD)	APP30T	APP60T	
Type								
Single	Double (BD)							
APP30T	APP60T							

Legend Plate ¹⁾	
<p>Black and Red</p>  <p>AP30</p>	
<p>Clear</p> <p>AP30T</p>	
<p>Plate dimensions (27 x 18 mm)</p>	

Flush Pushbutton Caps (color change)	
○ ACB0	
● ACB1	
● ACB2	
● ACB3	
● ACB4	
● ACB5	

Spare Lens (pilot lights)	
○ ALSD0	
● ALSD1	
● ALSD2	
● ALSD3	
● ALSD4	

Tools	
	CPAW Fixing tool
	ACEF Lamp extractor

Emergency Pushbutton Protection	
APEG	

Pushbutton Protections	
APBF - Flush Pushbutton	
APBI - Extended Pushbuttons	
APBD - Double Pushbutton	

Hole Plug	
ATR	

Blank ID Plate	
APN	

Emergency-Stop Plate	
APE	

Reduction ring 30mm to 22mm	
AR30	

Note: 1) Plates engraved on request

Pushbuttons and Pilot Lights - CSW Series (Ø 22mm) - Technical Data

Standards	IEC/EN 60947-5-1. VDE 0660. UL 508. UL 50. CENELEC EN 50007. EN418(CSW-BES). IEC60947-5-5(CSW-BES)		
Certifications	CE. cULus. IRAM		
Rated insulation Voltage	690V (IEC/EN 60947-1)		
Rated impulse Voltage	2.5kV (IEC/EN 60947-1)		
Degree of Protection	IP66 (IEC 60529)		
Terminal Degree of Protection	NEMA 1. 2. 3. 3R. 3S. 4. 4X. 5. 12. 12K and 13 according to UL 508		
Terminal Degree of Protection	IP2X (IEC 60529)		
Conventional Thermal Current I_{th}	10A		
Electrical performance according to IEC 60947-5-1 of auxiliary contacts	Utilization category AC-15	U _e (V)	I _e (A)
		24	10
		48	10
		60	10
		110	6
		220	3
		380	2
		500	1.5
	Utilization category DC-13	U _e (V)	I _e (A)
		24	2.5
		48	1.4
		60	1
		110	0.55
		220	0.27
Performance according to UL and CSA	AC / Heavy Duty (A600)		
	DC / Standard Duty (Q600)		
Contact Resistance	≤ 25m Ω (IEC 60255)		
Protection against short circuit	16A gL/gG fuses in accordance with IEC 60269-1 and IEC 60269-3		
Electrical shock protection	MPW16-3-U010 Motor protective circuit breaker		
Terminal Capacity	Class II (IEC 60536)		
Ambient Temperature Allowed	Min: (1 x 0.5 mm ²) and Max: (2 x 2. 5 mm ²)		
Shock Resistance	-25°C to 70°C		
Shock Resistance	No damage or disassembling up to 100g (½ senoid 11ms. in accordance with MIL 202B method 202A)		
Vibration Resistance	16g for a frequency range of 40 to 500Hz (IEC/EN 6068-2-6.) Maximum displacement 0.75 mm (peak to peak)		
Mechanical Lifespan			
Pushbuttons	3 x 10 ⁶ operations		
Switches	1 x 10 ⁶ operations		
Emergency Pushbuttons	3 x 10 ⁵ operations		
Maximum number of contacts	3 position flange	5 position flange	
BF. BGA Pushbuttons	Max 6	Max 10	
BC. BD. BFI. BSI and BCI pushbuttons and switches	Max 4	Max 8	
BEG. BEY. BESG. BESP and BESY emergency pushbuttons	Max 2	-	

BIDL block ratings

Rated operation voltage	0.85 ... 1.10 x U _e
Consumption	20mA
Rated impulse Voltage U_i	2.5kV (IEC/EN 60947-1)
Ambient Temperature Allowed	- 25°C to 70°C
Mechanical Lifespan	100.000h
Brightness	Red 70 mcd
	Yellow 115 mcd
	White 275 mcd
	Blue 64 mcd
	Green 150 mcd

Pushbuttons and Pilot Lights - CSW Series (Ø 22mm) - Dimensions (mm)

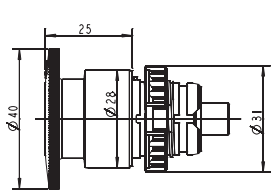

BEG

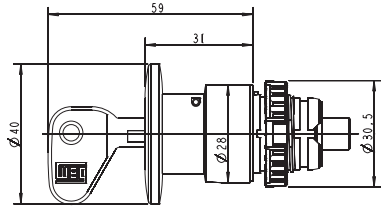

BEY

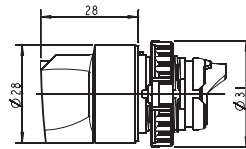

CK

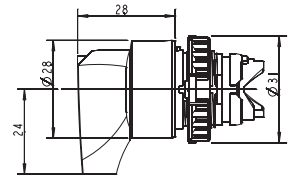

CA

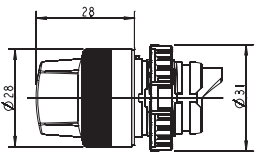

CKI

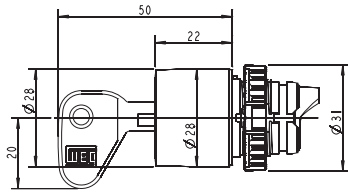

CY

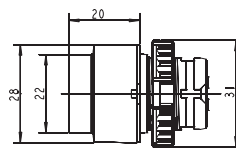

BSI

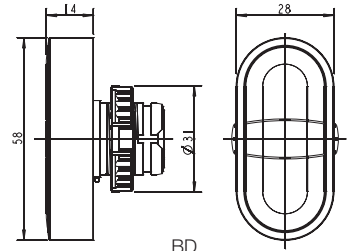

BD

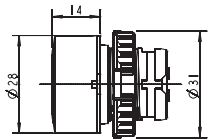

BF

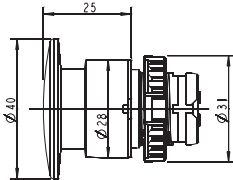

BC1
BCI

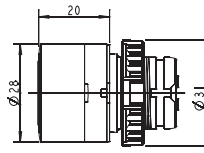

BFI
BGA

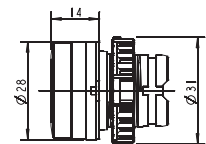

SD

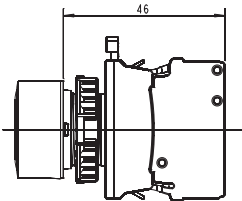

BF + AF3 + BC

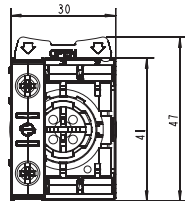

BF + AF3 + BC (double)

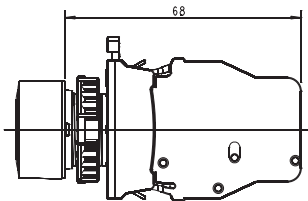

BFI + AF3 + BR + BIDL

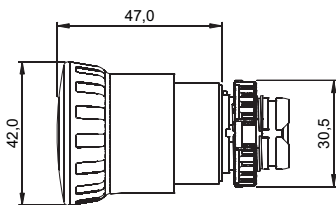
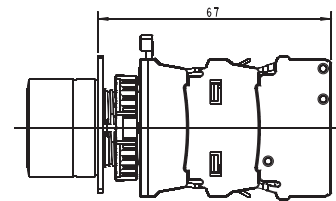

BESG

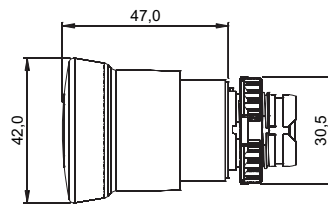

BESE

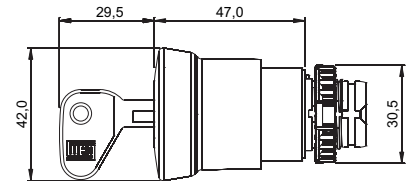

BESY

Pushbuttons and Pilot Lights - CSW Series (Ø 22mm) - Dimensions (mm)

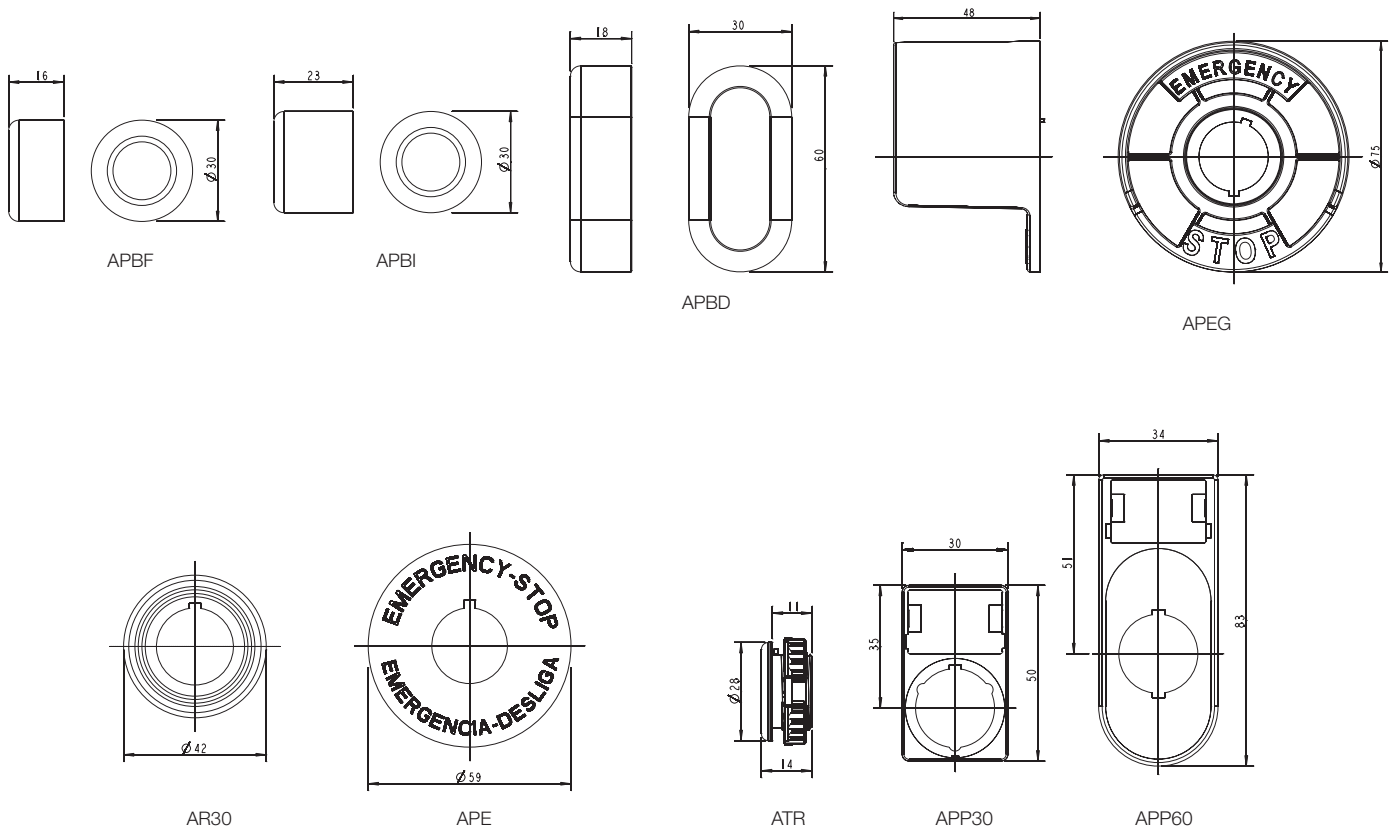

Installation Distance

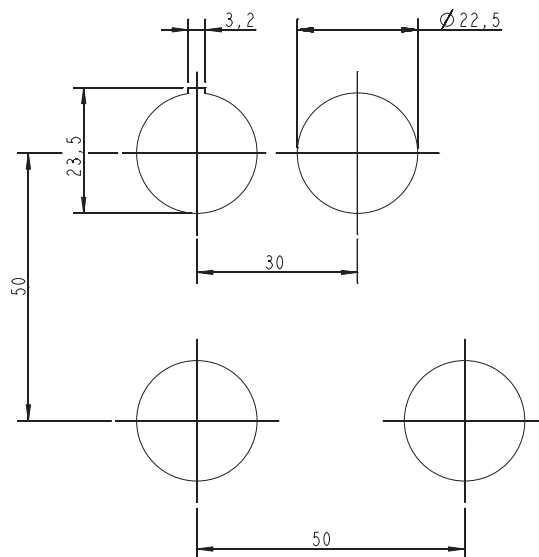

Pushbuttons and Pilot Lights - CSW Series (Ø 22mm) - Assembled Units

Pushbuttons



Reference Code	Description	Configuration
CSW-BF1-0100000	FLUSH PUSHBUTTON - RED - 1 NC	BF1 + BC01
CSW-BF2-1000000	FLUSH PUSHBUTTON - GREEN - 1 NO	BF2 + BC10
CSW-BF5-1000000	FLUSH PUSHBUTTON - BLACK - 1 NO	BF5 + BC10
CSW-BC1-0100000	MUSHROOM PUSHBUTTON - RED - 1 NC	BC1 + BC01
CSW-BC2-1000000	MUSHROOM PUSHBUTTON - GREEN - 1 NO	BC2 + BC10
CSW-BEG-0100000	EMERGENCY PUSHBUTTON - RED - 1 NC	BEG + BC01
CSW-BD-1100000	DOUBLE PUSHBUTTON - GREEN/RED - 1 NO + 1 NC	BD + BC10 + BC01

Illuminated Pushbuttons



Reference Code	Description	Configuration
CSW-BF1-0100000D61	ILLUMINATED EXTENDED PUSHBUTTON - RED - 1 NC - 110-130VAC	BF1 + BC01 + BIDL-1D61
CSW-BF1-0100000D66	ILLUMINATED EXTENDED PUSHBUTTON - RED - 1 NC - 220-240VAC	BF1 + BC01 + BIDL-1D66
CSW-BF2-1000000D61	ILLUMINATED EXTENDED PUSHBUTTON - GREEN - 1 NO - 110-130VAC	BF2 + BC10 + BIDL-2D61
CSW-BF2-1000000D66	ILLUMINATED EXTENDED PUSHBUTTON - GREEN - 1 NO - 220-240VAC	BF2 + BC10 + BIDL-2D66
CSW-BD-1000000D61	ILLUMINATED DOUBLE PUSHBUTTON - GREEN/RED - 1 NO + 1 NC - 110-130VAC	BD + BC10 + BC01 + BIDL-1D61
CSW-BD-1100000D66	ILLUMINATED DOUBLE PUSHBUTTON - GREEN/RED - 1 NO + 1 NC - 220-240VAC	BD + BC10 + BC01 + BIDL-1D66

Color Table

Color	Clear/White	Red	Green	Yellow	Blue	Black ¹⁾
Code	0	1	2	3	4	5
Symbol	○	●	●	●	●	●

Note: 1) Black color not available for WEG illuminated pushbuttons

Pushbuttons and Pilot Lights - CSW Series (Ø 22mm) - Assembled Units

Selector Switches



Reference Code	Description	Composition
CSW-CK2F45-1000000	SELECTOR SWITCH KNOB - 2 FIXED POSITIONS - 1 NO	CK2F45 + BC10
CSW-CK3F45-2000000	SELECTOR SWITCH KNOB - 3 FIXED POSITIONS - 2 NO	CK3F45 + BC10 + BC10
CSW-CA2F45-1000000	SELECTOR SWITCH LEVER - 2 FIXED POSITIONS - 1 NO	CA2F45 + BC10
CSW-CA3F45-2000000	SELECTOR SWITCH LEVER - 3 FIXED POSITIONS - 2 NO	CA3F45 + BC10 + BC10

Illuminated Selector Switches



Reference Code	Description	Composition
CSW-CKI2F901-1000000D61	ILLUMINATED SELECTOR SWITCH - RED - 2 FIXED POSITIONS - 1 NO - 110-13VAC	CKI2F901 + BC10 + BIDL-1D61
CSW-CKI2F901-1000000D66	ILLUMINATED SELEC. SWITCH - RED - 2 FIXED POSITIONS - 1 NO - 220-240VAC	CKI2F901 + BC10 + BIDL-1D66
CSW-CKI2F902-1000000D61	ILLUMINATED SELEC. SWITCH - GREEN - 2 FIXED POSITIONS - 1 NO - 110-130VAC	CKI2F902 + BC10 + BIDL-2D61
CSW-CKI2F902-1000000D66	ILLUMINATED SELEC. SWITCH - GREEN - 2 FIXED POSITIONS - 1 NO - 220-240VAC	CKI2F902 + BC10 + BIDL-2D66
CSW-CKI3F451-2000000D61	ILLUMINATED SELEC. SWITCH - RED - 3 FIXED POSITIONS - 2 NO - 110-130VAC	CKI3F451 + (2x) BC10 + BIDL-1D61
CSW-CKI3F451-2000000D66	ILLUMINATEDSELEC. SWITCH - RED - 3 FIXED POSITIONS - 2 NO - 220-240VAC	CKI3F451 + (2x) BC10 + BIDL-1D66
CSW-CKI3F452-2000000D61	ILLUMINATED SELEC. SWITCH - GREEN - 3 FIXED POSITIONS - 2 NO - 110-130VAC	CKI3F452 + (2x) BC10 + BIDL-2D61
CSW-CKI3F452-2000000D66	ILLUMINATED SELEC. SWITCH - GREEN - 3 FIXED POSITIONS - 2 NO - 220-240VAC	CKI3F452 + (2x) BC10 + BIDL-2D66

Pilot Lights



Reference Code	Description	Composition
CSW-SD1-D61	PILOT LIGHT - RED - 110-130VAC	SD1 + BIDL-1D61
CSW-SD1-D66	PILOT LIGHT - RED - 220-240VAC	SD1 + BIDL-1D66
CSW-SD2-D61	PILOT LIGHT - GREEN - 110-130VAC	SD2 + BIDL-2D61
CSW-SD2-D66	PILOT LIGHT - GREEN - 220-240VAC	SD2 + BIDL-2D66

Electronic Relays

Monitoring Relays RPW

Timing Relays RTW

Level Relays RNW

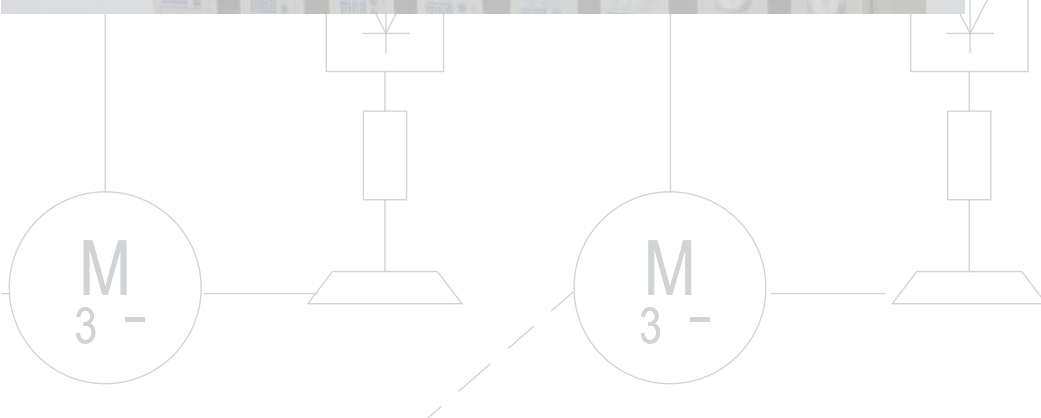
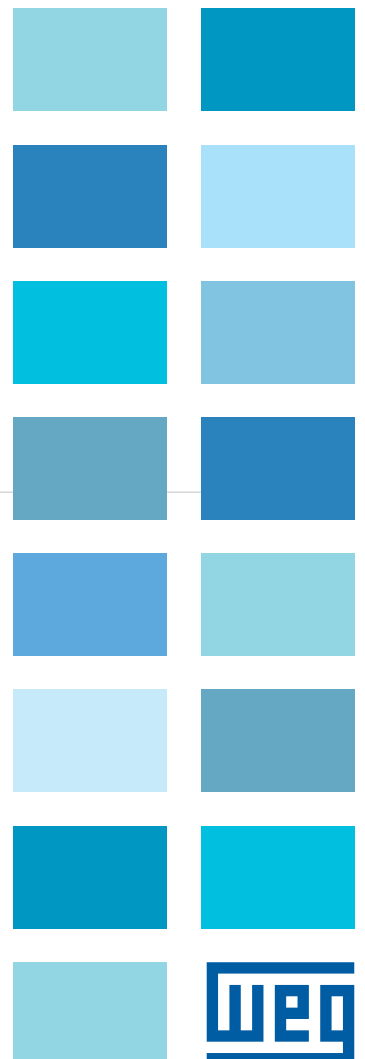

WEG Electronic Relays

- High precision electronic circuit with noise immunity.
- Compact, with a 22.5mm width frame, direct mounting on DIN rail 35mm or fixed with screws.
- Equipped with reliability LED for status indications.



Standards

- IEC / EN1812-1
- IEC / EN 60947-1
- IEC / EN 60947-5-1
- UL508 CAN/CSA C22.2

Certifications



- New RPW SS over and under voltage Electronic Protection and RPW PTC Thermistor Relays.
- RTW Timing Relays with 2 timing ranges (adjustable from 0.1 sec up to 150 hours) and 9 functions.
- Compact, only 22.5 mm, wide, can be assembled on DIN rail 35mm or with screws.
- Provided with high precision electronic circuit and line noise immunity.
- LED for status indication.
- High reliability contacts.

Timing Relay RTW

Ideal for applications such as industrial processes, automation and motor starters, RTW timing relays switch an output signal based on a selected time and function.

With a 22.5 mm width frame the RTW is supplied as a competitive solution including the following features:

- Direct mounting on DIN rail 35 mm or fixed with screws;
- 1 or 2 output contacts (NOC);
- RE – On-Delay
- RD – Off-Delay
- RDI – Off-Delay without Control Voltage
- PE – Impulse On
- CI – Asymmetric Flasher Start ON
- CIR – Asymmetric Flasher Start OFF
- CIL – Symmetric Flasher - Start ON
- CID – Symmetric Flasher - Start OFF
- ET – Star - Delta



Monitoring Relays RPW

RPW monitoring relays are a competitive choice for monitoring voltage to protect against the most common types of electrical failures. Monitoring voltages in electric installations are important for several reasons. Overvoltage, or phase loss, can cause machinery and motors, thus reducing overheating, their lifetime. Phase sequence inversion can cause machinery to run in a wrong way, then destroying the entire system, and undervoltage may occur causing machinery to run in an undefined range, which could cause some parts of a system to run properly while others cease operating.

With five different functions, the RPW series are ideal to be used in electric motor control panel applications.

- RPW SF – Phase Sequence Relay
- RPW FF – Phase Loss Relay
- RPW FSF – Phase Sequence and Phase Loss Relay
- RPW SS – Under and Overvoltage Relay
- RPW PTC – Thermistor Relay



Level Relay RNW

These electronic control devices enable the monitoring and automatic level adjustment of the electrical current liquid conductor. Widely used in reservoir automation in general. They can be used in several applications.

The RNW Level Relay line with 22.5 mm wide housing offers the following functions:

- RNW EN - Filling
- RNW ES - Draining



Timing Relays RTW

Ideal for applications such as industrial processes, automation and motor starters, RTW timing relays switch an output signal based on a selected time and function.

With a 22.5 mm width frame the RTW is a competitive solution with:

- Direct mounting on DIN rail 35 mm or fixed with screws using the PLMP accessory;
- 1 or 2 output contacts (NO/NC).
- Wide Supply voltage: 24-240VAC 50/60Hz / VDC
- 2 timing ranges, adjustable from 0,1 seconds to 150 hours, with 9 different functions.

Offered in the following timing functions:

- RTW- RE → On-Delay
- RTW- RD → Off-Delay
- RTW- RDI → Off-Delay without Control Voltage
- RTW- PE → Impulse On
- RTW- CI → Asymmetric Flasher Start ON
- RTW- CIR → Asymmetric Flasher Start OFF
- RTW- CIL → Symmetric Flasher - Start ON
- RTW-CID → Symmetric Flasher - Start OFF
- RTW- ET → Star – Delta ⁽¹⁾



Standards IEC / EN1812-1
IEC / EN 60947-1
IEC / EN 60947-5-1

Certifications

Selection

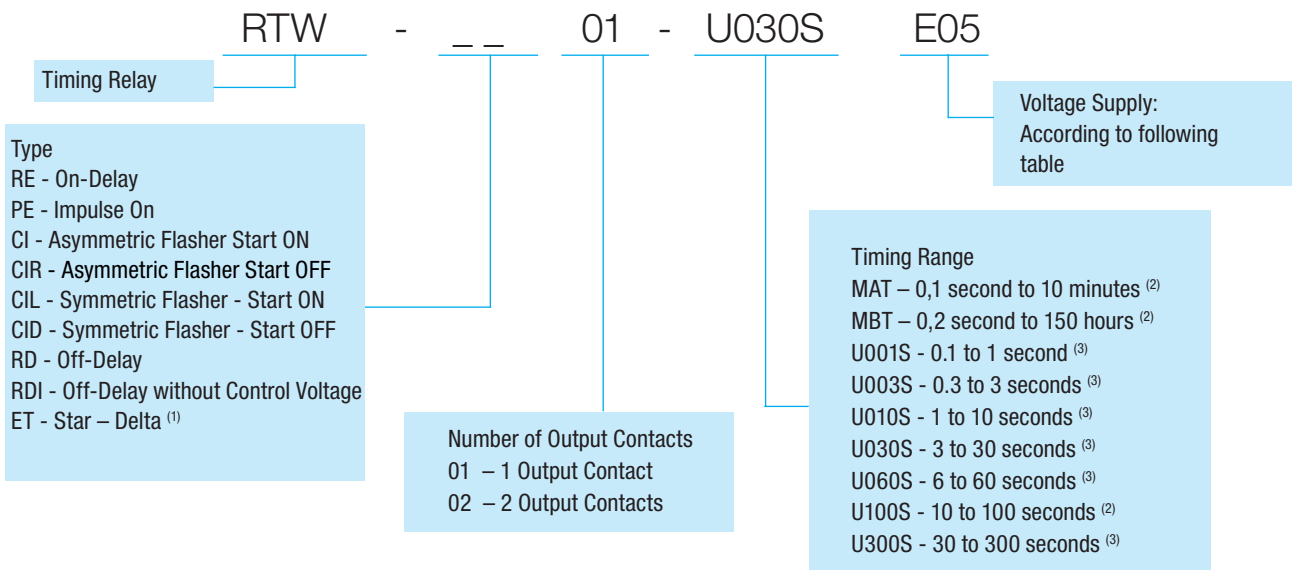

Code	Voltage	RTW-RE	RTW-PE	RTW-CI	RTW-CIR	RTW-CIL	RTW-CID	RTW-RD	RTW-RDI	RTW-ET
E05	24-240VAC 50/60 Hz/ VDC	X	X	X	X	X	X	X	X	X
E26	24VAC 50/60Hz / 24VDC			X	X					
E33	48VAC 50/60Hz / 24VDC			X	X					
E37	110-130VAC 50/60Hz / 24VDC			X	X					
E40	220-240VAC 50/60Hz / 24VDC			X	X					

Notes:

- (1) Star-Delta function requires 2 output contacts and MAT timing range
- (2) Timing ranges not available for RTW-CI/CIR/RDI
- (3) Timing ranges available for RTW-CI/CIR/RDI

Functions

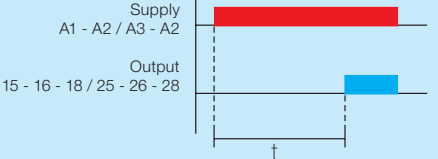
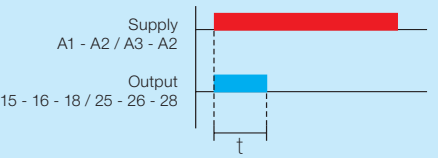
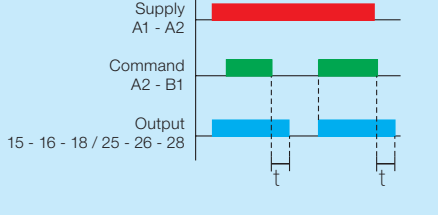
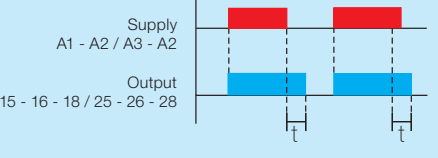
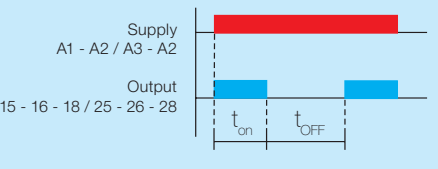
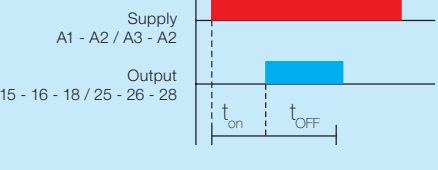
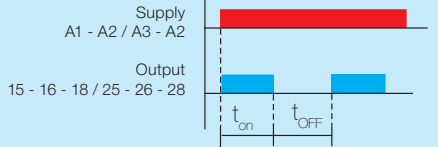
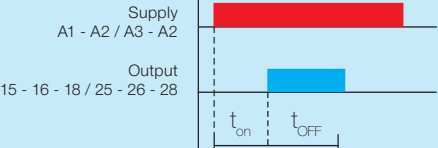
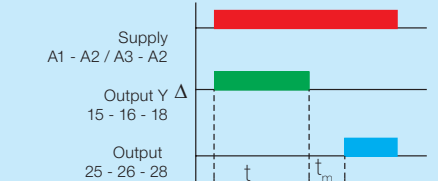
Operating Mode	Timing Diagram
<p>RTW RE (ON - Delay) – Connecting a supply voltage on terminals A1-A2 / A3-A2 the selected time delay begins and the green LED switches on. After the end of the delay time the output relay picks up (red LED turns on) and remains energized until the supply voltage is removed. This can be repeated as often as required. Reset: Removing supply voltage resets the time delay and the output.</p>	
<p>RTW PE (Impulse On) – Connecting a supply voltage on terminals A1-A2 / A3-A2 (green LED turns on) the output relay picks up without delay (red LED turns on) and remains energized until the selected pulse time elapse (red LED turns OFF). This can be repeated as often as required. Reset: Removing supply voltage resets the time delay and the output.</p>	
<p>RTW RD (OFF Delay) – This function requires continuous supply voltage on terminals A1-A2 (green LED turns on) and timing is controlled by a command contact at terminals A2-B1. If the command contact is energized, the output relay picks up (red LED turns on) and after the command contact is removed the selected time delay begins. When the selected time elapse the output relay is de-energized (red LED turns OFF). This can be repeated as often as required. Reset: Removing supply voltage resets the time delay and the output.</p>	
<p>RTW RDI (OFF Delay with no control) – Connecting a supply voltage on terminals A1-A2 / A3-A2, the green LED turns on and the output relay picks up without delay (red LED turns on). If the supply voltage is de-energized, the selected time delay begins and when this time elapse, the output relay is de-energized (red LED turns OFF). This can be repeated as often as required. Reset: Removing supply voltage resets the time delay and the output.</p>	
<p>RTW CI (Asymmetric Flasher Start ON) – Connecting a supply voltage on terminals A1-A2 / A3-A2 the green LED turns on and the timer starts to pulse with adjustable ON/OFF cycles. The upper dial presets the ON time (red LED turns ON and output relay picks up) and the lower select the OFF time when the output relay is de-energized. Reset: Removing supply voltage resets the time delay and the output.</p>	
<p>RTW CIR (Asymmetric Flasher Start OFF) – Connecting a supply voltage on terminals A1-A2 / A3-A2 the green LED turns on and the timer starts to pulse with adjustable OFF/ON cycles. The upper dial presets the ON time (red LED turns ON and output relay picks up) and the lower select the OFF time when the output relay is de-energized. Reset: Removing supply voltage resets the time delay and the output.</p>	
<p>RTW CIL (Symmetric Flasher -Start ON) – Connecting a supply voltage on terminals A1-A2 / A3-A2 the green LED turns on and the timer starts to pulse with symmetric ON/OFF cycles. The dial presets a fixed ON time (red LED turns ON and output relay picks up) and OFF time. Reset: Removing supply voltage resets the time delay and the output.</p>	
<p>RTW CID (Symmetric Flasher - Start OFF) – Connecting a supply voltage on terminals A1-A2 / A3-A2 the green LED turns on and the timer starts to pulse with symmetric OFF/ON cycles. The dial presets a fixed ON time (red LED turns ON and output relay picks up) and OFF time. Reset: Removing supply voltage resets the time delay and the output.</p>	
<p>RTW ET (Star-Delta) – Connecting a supply voltage on terminals A1-A2 / A3-A2 the output relay for the wye-connection picks up and the adjusted time starts (red LED turns ON). When the start-up time elapses, a fixed star-delta changeover time of 100 ms starts and after this star-delta changeover time elapses the output relay for the delta-connection picks up and stays energized until the supply is disconnected. Reset: Removing supply voltage resets the time delay and the output.</p>	

Where: t , t_{ON} , t_{OFF} adjusted time, t_M Dead time

Characteristics

Connection Diagrams

		RTW - RE		RTW - PE		RTW - CI / CIL / CID / CIR		RTW - RD / RDI		RTW - ET
		1E	2E	1E	2E	1E	2E	1E	2E	2E
Terminal positions		A1 15 A3 RTW RE 16 18 A2	A1 15 A3 RTW RE 25 26 28 16 18 A2	A1 15 A3 RTW PE 16 18 A2	A1 15 A3 RTW PE 25 26 28 16 18 A2	A1 15 A3 RTW CI 16 18 A2	A1 15 A3 RTW CI 25 26 28 16 18 A2	A1 15 B1 RTW RD 16 18 A2	A1 15 B1 RTW RD 25 26 28 16 18 A2	A1 15 A3 RTW ET 25 26 28 16 18 A2
	Diagram									
Circuit	A1 - A2 Supply voltage	24-240VAC/VDC (50/60Hz)		24-240VAC/VDC (50/60Hz)		220-240V, 24-240VAC/VDC (50/60Hz)		24-240VAC/VDC (50/60Hz)		24-240VAC/VDC (50/60Hz)
	A2 - A3 Supply voltage	Voltage 24 VDC		Voltage 24 VDC		Voltage 24 VDC		x		Voltage 24 VDC
	A2 - B1 Control voltage	x		x		x		Voltages 24-240VAC/VDC (50/60Hz)		x
	15 - 16 - 18	Output 1		Output 1		Output 1		Output 1		Output 1
	25 - 26 - 28	Output 2		Output 2		Output 2		Output 2		Output 2

Timing Relay Adjustment

The desired timing must be adjusted through its front adjustment DIAL, the scale of which is presented in seconds for all timing, except for the 3 to 30 minute scale.

RTW-CI / CIR / RDI	RTW-RE / PE / CIL / CID / RD	RTW-ET
0.1 sec to 1 sec	0.1 sec to 10 min 0.2 sec to 150 h	0.1 sec to 10 min
0.3 sec to 3 sec		
1 sec to 10 sec		
3 sec to 30 sec		
6 sec to 60 sec		
30 sec to 300 sec		
3 min to 30 min		

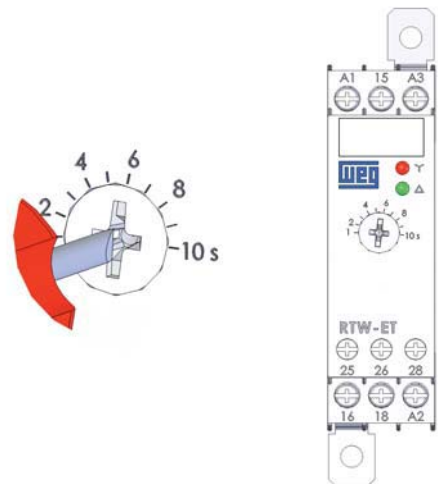

Light indications on Relay

The RTW Timing Relay has status indicator LEDs, as shown below:

RTW - RE	RTW-PE RTW-CI/CIR/CIL/CID RTW-RD/RDI	RTW - ET
Red LED	Energized Output	Star Output
Green LED	Energized Relay	Delta Output

The RTW relays can be individually mounted on DIN 35mm rail or with screws using the PLMP accessory.

Reference Table

On-Delay

Function	Contacts	Supply Terminals		Control Terminals	Timing	Reference Code
		A1-A2	A2-A3	A2-B1		
		Voltage (V)				
	1NOC	24-240VAC/VDC (50/60Hz)	24-240VAC/VDC (50/60Hz)	-	0.1 sec to 10 min 0.2 sec to 150 h	RTW-RE 01 - MAT RTW-RE 01 - MBT
	2NOC	24-240VAC/VDC (50/60Hz)	24-240VAC/VDC (50/60Hz)	-	0.1 sec to 10 min 0.2 sec to 150 h	RTW-RE 02 - MAT RTW-RE 02 - MBT

Off-Delay

Function	Contacts	Supply Terminals		Control Terminals	Timing	Reference Code
		A1-A2	A2-A3	A2-B1		
		Voltage (V)				
	1NOC	24-240VAC/VDC (50/60Hz)	-	24-240VAC/VDC (50/60Hz)	0.1 sec to 10 min 0.2 sec to 150 h	RTW-RD 01 - MAT RTW-RD 01 - MBT
	2NOC	24-240VAC/VDC (50/60Hz)	-	24-240VAC/VDC (50/60Hz)	0.1 sec to 10 min 0.2 sec to 150 h	RTW-RD 02 - MAT RTW-RD 02 - MBT
		24-240VAC(50/60Hz) / VDC				

Off-Delay without control voltage

Function	Contacts	Voltage (V) - Terminals		Timing	Reference Code
		A1-A2			
	1NOC	24-240VAC/VDC (50/60Hz)		0.1 to 1 sec 0.3 to 3 sec 1 to 10 sec 3 to 30 sec 6 to 60 sec 10 to 100 sec 30 to 300 sec 1 to 10 min	RTW RDI 01 - U001S RTW RDI 01 - U003S RTW RDI 01 - U010S RTW RDI 01 - U030S RTW RDI 01 - U060S RTW RDI 01 - U100S RTW RDI 01 - U300S RTW RDI 01 - U010M
	2NOC	24-240VAC/VDC (50/60Hz)		0.1 to 1 sec 0.3 to 3 sec 1 to 10 sec 3 to 30 sec 6 to 60 sec 10 to 100 sec 30 to 300 sec 1 to 10 min	RTW RDI 02 - U001S RTW RDI 02 - U003S RTW RDI 02 - U010S RTW RDI 02 - U030S RTW RDI 02 - U060S RTW RDI 02 - U100S RTW RDI 02 - U300S RTW RDI 02 - U010M

Reference Table

Impulse - ON

Function	Contacts	Supply Terminals		Control Terminals	Timing	Reference Code
		A1-A2	A2-A3	A2-B1		
		Voltage (V)				
	1NOC	24-240VAC/VDC (50/60Hz)	24-240VAC/VDC (50/60Hz)	-	0.1 sec to 10 min 0.2 sec to 150h	RTW-PE 01 - MAT RTW-PE 01 - MBT
	2NOC	24-240VAC/VDC (50/60Hz)	24-240VAC/VDC (50/60Hz)	-	0.1 sec to 10 min 0.2 sec to 150h	RTW-PE 02 - MAT RTW-PE 02 - MBT

Asymmetric Flasher

Function	Contacts	Supply Terminals		Control Terminals	Timing	Reference Code
		A1-A2	A2-A3	A2-B1		
		Voltage (V)				
	1NOC	24V. 48V. 110-130V. 220-240V 24-240VAC/VDC (50/60Hz)	24VDC	-	0.1 to 1 sec 0.3 to 3 sec 1 to 10 sec 3 to 30 sec 6 to 60 sec 10 to 100 sec 30 to 300 sec 3 to 30 min	RTW-CI/CIR 02 - U002S RTW-CI/CIR 02 - U003S RTW-CI/CIR 02 - U020S RTW-CI/CIR 02 - U030S RTW-CI/CIR 02 - U060S RTW-CI/CIR 02 - U100S RTW-CI/CIR 02 - U300S RTW-CI/CIR 02 - U030M
	2NOC	24V. 48V. 110-130V. 220-240V 24-240VAC/VDC (50/60Hz)	24VDC	-	0.1 to 1 sec 0.3 to 3 sec 1 to 10 sec 3 to 30 sec 6 to 60 sec 10 to 100 sec 30 to 300 sec 3 to 30 min	RTW-CI/CIR 02 - U002S RTW-CI/CIR 02 - U003S RTW-CI/CIR 02 - U020S RTW-CI/CIR 02 - U030S RTW-CI/CIR 02 - U060S RTW-CI/CIR 02 - U100S RTW-CI/CIR 02 - U300S RTW-CI/CIR 02 - U030M

Symmetric Flasher

Function	Contacts	Supply Terminals		Control Terminals	Timing	Reference Code
		A1-A2	A2-A3	A2-B1		
		Voltage (V)				
	1NOC	24-240VAC/VDC (50/60Hz)	24-240VAC/VDC (50/60Hz)	-	0.1 sec to 10 min 0.2 sec to 150 h	RTW-CIL/CID 01 - MAT RTW-CIL/CID 01 - MBT
	2NOC	24-240VAC/VDC (50/60Hz)	24-240VAC/VDC (50/60Hz)	-	0.1 sec to 10 min 0.2 sec to 150 h	RTW-CIL/CID 02 - MAT RTW-CIL/CID 02 - MBT

Y / Δ

Contacts	Supply Terminals		Control Terminals	Timing	Reference Code
	A1-A2	A2-A3	A2-B1		
	Voltage (V)				
2NOC	24-240VAC/VDC (50/60Hz)	24-240VAC/VDC (50/60Hz)	-	0.1 sec to 10 min	RTW ET 02 - MAT

Monitoring Relays RPW

WEG RPW Relays are electronic devices that protect three phase systems against phase loss or neutral loss (selectable) (RPW FF), phase sequence inversion (RPW SF) or both of the functions integrated into the same product (RPW FSF). Whenever there is failure in the three phase system the relay will work to interrupt the motor or process operation to be protected.

Designed in accordance with international standards, the RPW Monitoring Relays Offer a compact and competitive solution, with 22.5mm wide housing for assembly on DIN 35mm rail.

RPW SF



Standards

IEC / EN 60947-1
IEC / EN 60947-5-1

Certifications



The Phase Sequence Relay is designed to protect three phase systems against phase sequence inversion (L1-L2-L3).
Functioning: on connecting the relay to the supply with the phase sequences correctly connected, the output relay switches the contacts to operation position (closing terminals 15-18) and the red LED turns on. When a phase sequence inversion occurs the output contacts will become de-energized (opening 15-18) and the red LED will turn OFF.

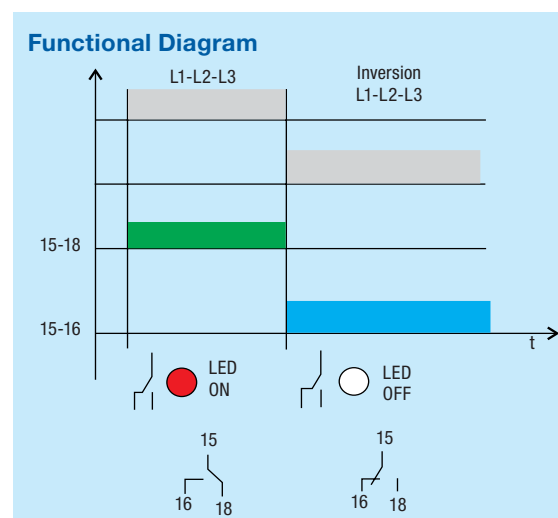
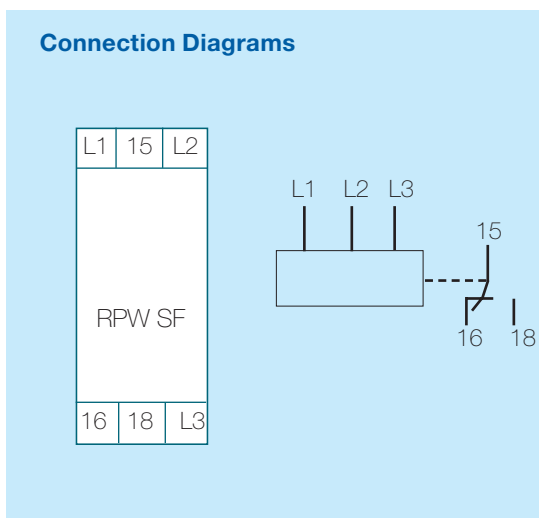
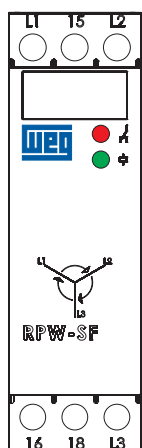

Light indicators on relay

The RPW Monitoring Relay is equipped with status indicator LEDs, as shown on the right:

Assembly

The RPW Relays can be individually mounted on DIN 35mm rail or with screws using the PLMP accessory.

RPW FF



RPW FF (neutral not selected)

The Phase Loss Relay is designed to protect three phase systems against phase loss with feedback.

Functioning: Directly connected to the supply to be monitored, feeding the 3 fuses with phase amplitude within the selected limits, the output relay switches the contacts to operation position (closing terminals 15-18) and the red LED switches on. When loss occurs in one of the phases in relation to the others to a value below the percentage limit selected through the sensitivity adjustment DIAL (monitoring against motor ghost phase) the output contact (opening 15-18) will become de-energized and the red LED indicating system running will switch OFF.

RPW FF (neutral selected)

Designed to protect three phase systems with neutral.

Functioning: In the same product, a bridge must be provided between terminals A and B for neutral monitoring. The relay will perform the same monitoring for phase loss and will also monitor the voltage in neutral, which must be connected. When this value exceeds 20V, there will be output de-energization (opening 15-18). A value considering unbalanced loads.

Note: When we monitor a motor, loss of a phase generates current raising of the remaining phases, which will cause motor overheating. Winding with armature voltage works as a voltage generator, called "ghost phase". The RPW FF will protect the motor in the situation.

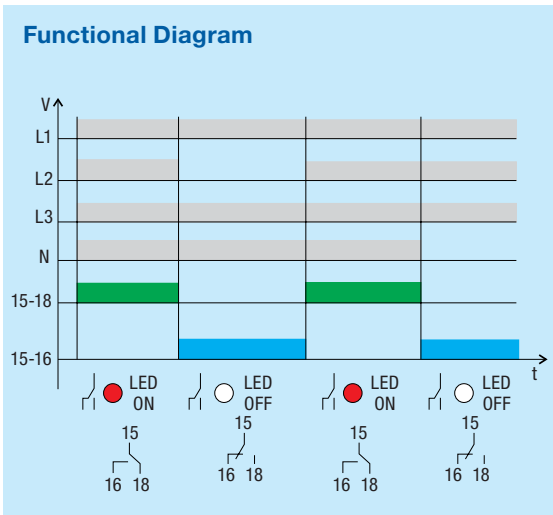
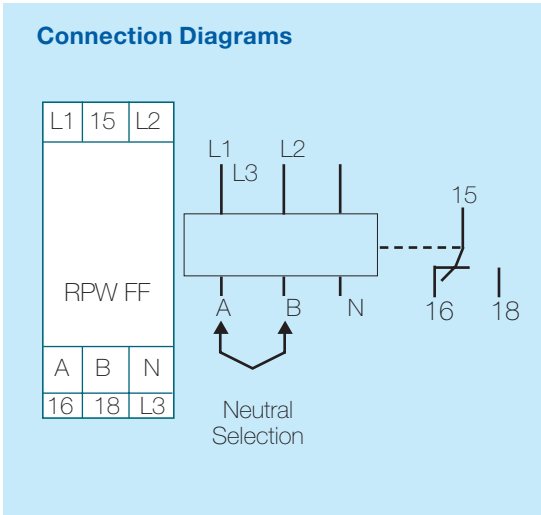
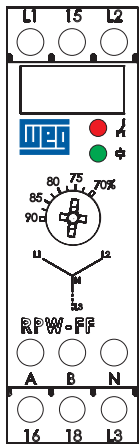
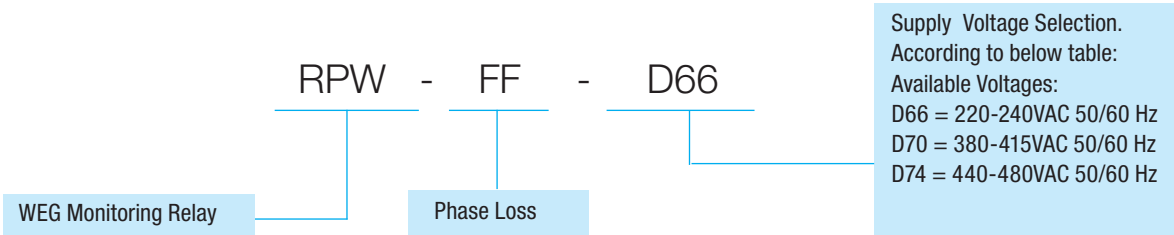

Relay Light Indications

Monitoring Relay RPW has status indicating LEDs, as shown on the right:

● Energized Output

● Energized Relay

Sensitivity Adjustment

Relay sensitivity adjustment must be performed through the adjustment Dial located on the front. Adjust the desired percentage from 70 to 90%, which will define the loss percentage of a phase in relation to the others.

Assembly
The RPW Relays can be individually mounted on DIN 35mm rail or with screws using the PLMP accessory.

RPW FSF



RPW FSF (neutral not selected)

The Phase Loss and Sequence Relay is designed to protect three phase systems against phase loss and reversions. Functioning: directly connected to the supply to be monitored, supplying the 3 phases and the phase amplitude to be within the selected limits and in the correct sequence, the output relay switches the contacts to the work position (closing terminals 15-18) and the red LED will switch on. When phase loss or reversion occurs the output contacts (opening 15-18) become de-energized and the red LED indicating system running switch OFF.

RPW FSF (neutral selected)

In the same product, a jumper must be made between terminals A and B for neutral monitoring, the relay will perform the same monitoring for phase loss and balancing and will also monitor the voltage in neutral, which must be connected. When the voltage at neutral exceeds 20V, value that considers unbalanced loads, there will be output de-energization (opens 15-18).

Selection

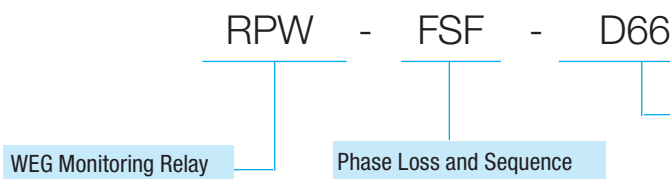

Supply Voltage Selection.
According to below table:
Available Voltages:
D66 = 220-240VAC 50/60 Hz
D70 = 380-415VAC 50/60 Hz
D74 = 440-480VAC 50/60 Hz

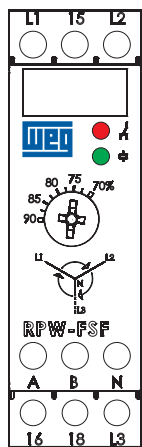

Connection Diagrams

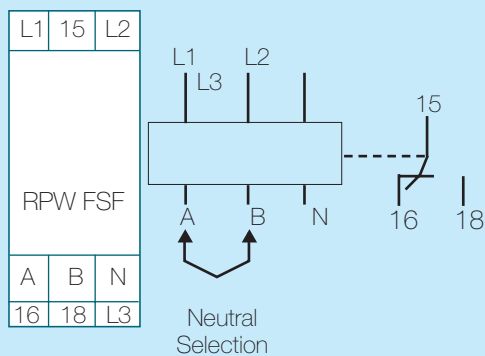

Functional Diagram

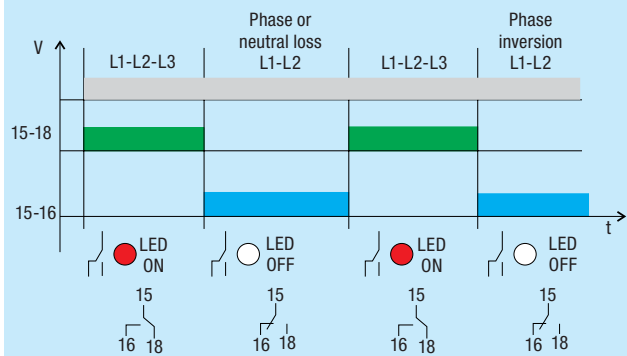

Relay Light Indications

Monitoring Relay RPW has status indicating LEDs, as shown on the right:

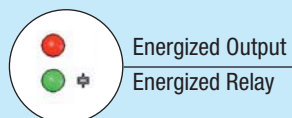

Sensitivity Adjustment

Relay sensitivity adjustment must be performed through the adjustment Dial located on the front, adjust the desired percentage from 70 to 90%, which will define the loss percentage of a phase in relation to the others.

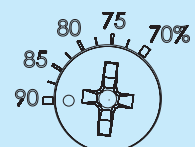

Assembly

The RPW Relays can be individually mounted on DIN 35mm rail or with screws using the PLMP accessory.

RPW SS



The WEG RPW SS Relay is designed to protect three phase systems against under or over voltage and phase loss.

Functioning: directly connected to the 3 three phases to be monitored (L1, L2 and L3) and being the phases amplitude within the sensitivity limits adjusted on the front scales, the relay switches the contacts to the operation position, (closing terminals 15 – 18) and the red LED will switch on. When any failure occurs in the system causing under or over voltage or even phase loss relay de-energization will occur (opening terminals 15-18) protecting the monitored equipment and the red LED turns OFF.

Selection

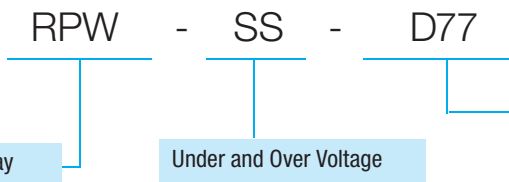

Voltage selection according to the below table:
Available Voltages:

D77 = 208VAC 50/60 Hz	D34 = 400VAC 50/60 Hz
D23 = 220VAC 50/60 Hz	D35 = 415VAC 50/60 Hz
D24 = 230VAC 50/60 Hz	D36 = 440VAC 50/60 Hz
D25 = 240VAC 50/60 Hz	D38 = 460VAC 50/60 Hz
D33 = 380VAC 50/60 Hz	D39 = 480VAC 50/60 Hz

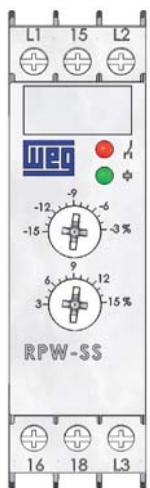

Connection Diagram

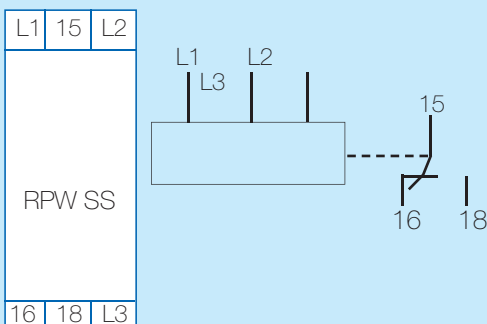

Functional Diagram

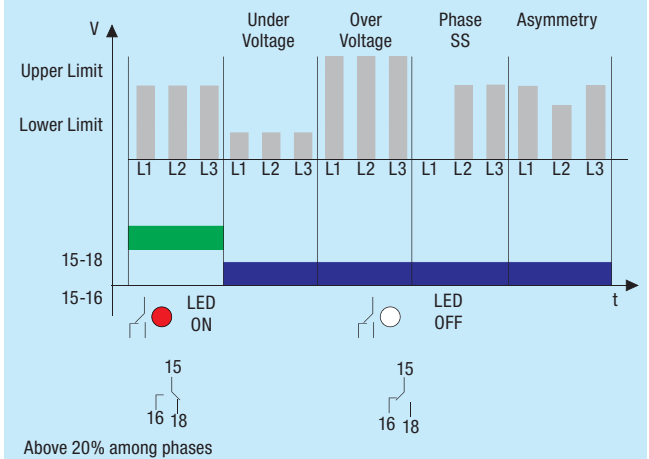

Relay Light Indications

	On	Normal Operation
	Off	Under, Overvoltage and Phase loss
	On	Energized
	Off	Energized

Sensitivity Adjustment

The sensitivity adjustment is performed by 2 Dials located on the front of the Relay. Selection is from -15% to -3% (for under voltage) and +3% to +15% (for over voltage).

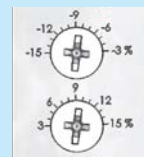

Assembly

The RPW Relays can be individually mounted on DIN 35mm rail or with screws using the PLMP accessory.

RPW PTC



The WEG RPW PTC Relay is an electronic monitoring device enabling monitoring against temperatures in excess of the given limit by PTC selection in machines (motors, generators, etc...) equipped with a PTC temperature detector.

Designed in accordance with international standards, the RPW PTC OFFers a safe and compact solution, with standardized 22.5mm boxes for insertion in DIN rail 35mm.



Functioning: The RPW PTC Relay must be series connected to PTC detectors (maximum of 3 detectors), and being energized, and at a temperature below the disarming value, the output relay will be instaneously switched (energized) ,activating the red LED.

If there is a temperature rise above the rated temperature an sudden variation in the PTC detector resistance will occur, and the output relay will be de-energized (red LED switches OFF), the relay will be energized again once the temperature returns to normal values. The RTW PTC is equipped with a PTC detector test device, and if this is in failure, there will be a LED indication (LED flashing) that the PTC is in short-circuit or open.

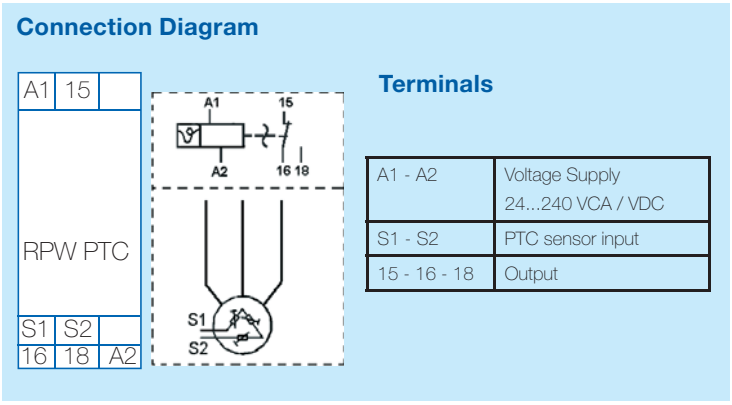
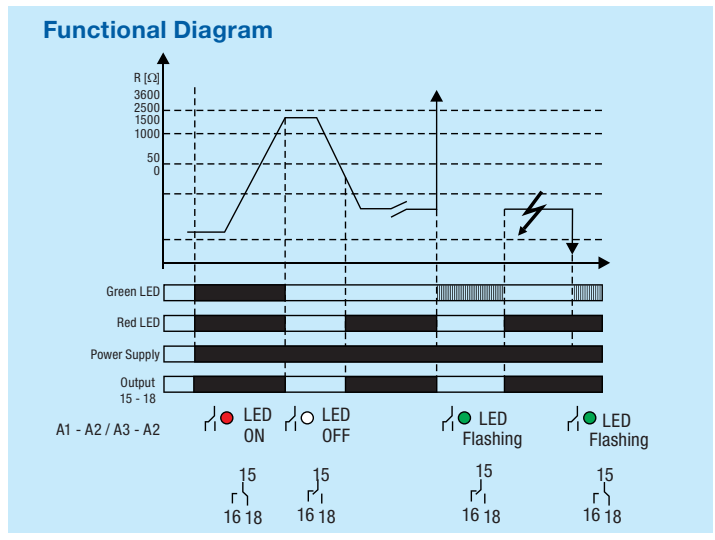
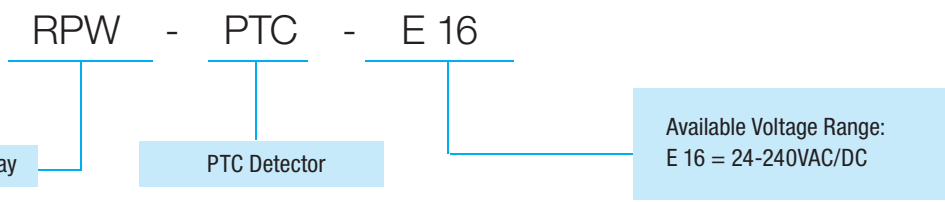
Selection



Relay Light Indications

	On	Normal Operation
	Off	Elevated Temperature
	On	Energized
	Off	Not energized
	Flashing	PTC sensor failure

The RPW Relays can be individually mounted on DIN 35mm rail or with screws using the PLMP accessory.

Level Relays RNW

The WEG Level Relays are electronic control devices that enable the monitoring and automatic adjustment of the level in electric current liquid conductors. Widely used in reservoir automation in general, the RNW relays can be used in several applications such as the prevention of dry pump operation, monitoring against filling tank overflow, activation of solenoids or alarms / lighting. The operating principle is based on the measuring of the electrical resistance of the reservoir liquid through an assembly of electrodes that work as liquid presence / absence sensors. To optimize their performance, the relay has a sensitivity DIAL enabling the electronic circuit to be adjusted to the liquid resistance. Available in 2 distinct functions, RNW EN filling and RNW ES draining, the relay Offers digital electronics that provide high precision, repeatability and noise resistance. The supply system is isolated from the electronic circuit therefore ensuring greater user safety. Designed in accordance with international standards, the RNW Offers a safe and compact solution, in 22,5mm wide housing for assembly on DIN rail 35mm, with 1 output with NO/NC reversable contact and an ample voltage supply range of 100-240 VAC/ VDC.

Available in the following functions:

- RNW EN -> Filling
- RNW ES -> Draining



Standards IEC / EN 60947-1
IEC / EN 60947-5-1



Selection

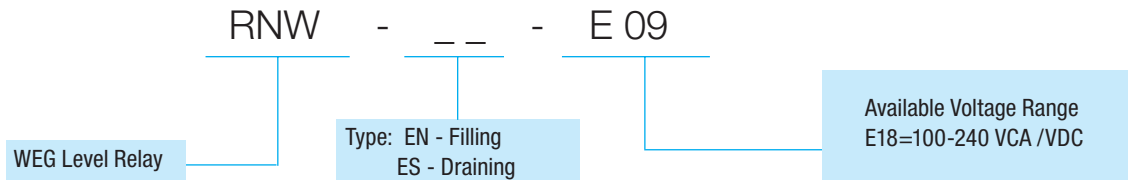

Functioning

The electrodes are fixed in the reservoir according to desired levels for control, minimum or maximum, and the reference electrode (C) must be positioned in the lower part, below the other electrodes, maximum level electrode (Max) and minimum level electrode (Min). When the system is energized an alternating current (the AC current minimizes the electrolysis and increases the life span of the electrode) is applied to the reference electrode, once the liquid comes into contact with the level electrodes a path is established for the circulation of electrical current between the electrodes. An electronic current compares the current and according to the chosen model (RNW ES or RNW EN) a logic will occur that switches the relay output contacts. The electrodes are available in 2 models, shaft (EHW) or pendulum (EPW), the difference between them is the way of fixing. In order to adapt the several applications the RNW is available in two distinct functions, draining and filling.

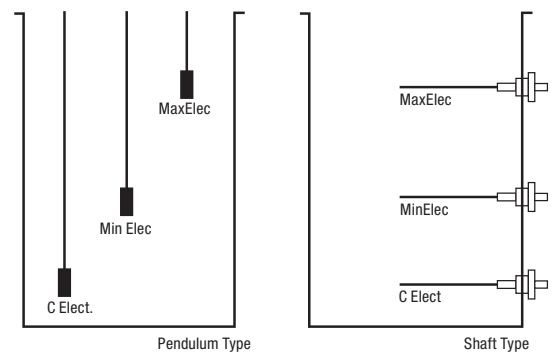

Note: The EHW can be fixed both horizontally and vertically

RNW EN (Filling)



Controls 2 levels using the 3 electrodes, the reference electrode (C), the maximum level electrode (Max) and the minimum level electrode (Min). Once supplied the RNW EN monitors the liquid level in the reservoir, with the electrode being uncovered at minimum level Min, the output relay will become energized (terminals 15-18 closed) causing the liquid level to rise. When the reservoir liquid covers the Max level electrode, the relay goes into a state of rest (terminals 15-18 open) and thus remains until the Min level electrode is discovered again. If there is a relay supply failure when resupplying the RNW EN monitors the liquid level and restart its initial logic.

Connection Diagrams

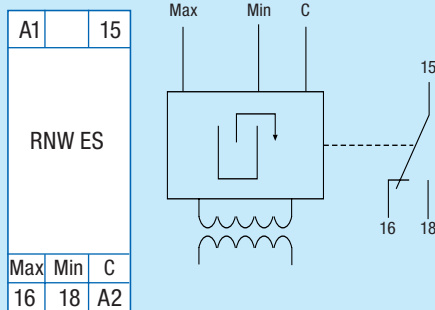

Funcional Diagram

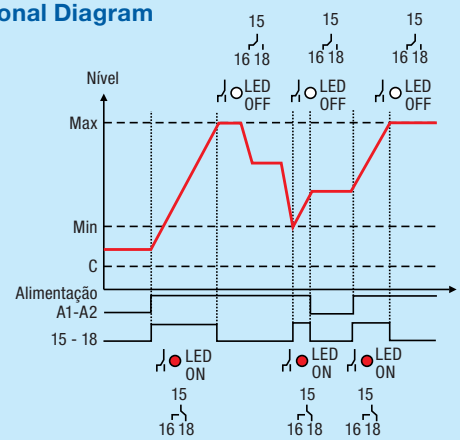

RNW ES (Draining)



Controls 2 levels using the 3 electrodes, the reference electrode (C), the maximum level electrode (Max) and the minimum level electrode (Min). Once supplied the RNW ES checks the liquid level in the reservoir, with this being in contact with the Max level electrode, the relay will become energized (terminals 15-18 closed), causing the reservoir liquid level begin to drop. Once the Min level electrode is uncovered by the liquid the relay will switch to rest status (terminals 15-18 open) and will thus remain until the liquid enters into contact again with the Max level electrode, restarting the process. If there is a relay supply failure when resupplying the RNW ES verifies the liquid level and restart its initial logic.

Connection Diagrams

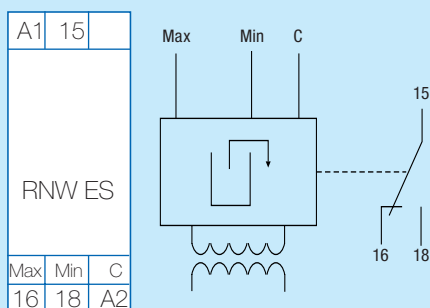

Funcional diagram

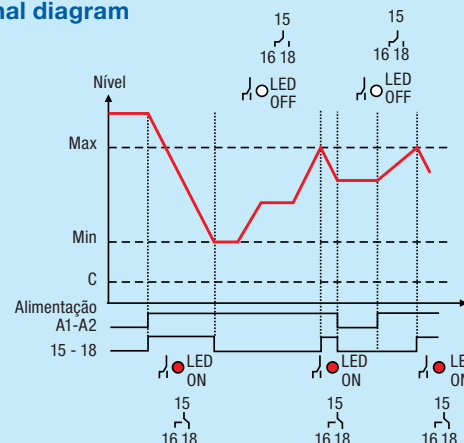

Applications

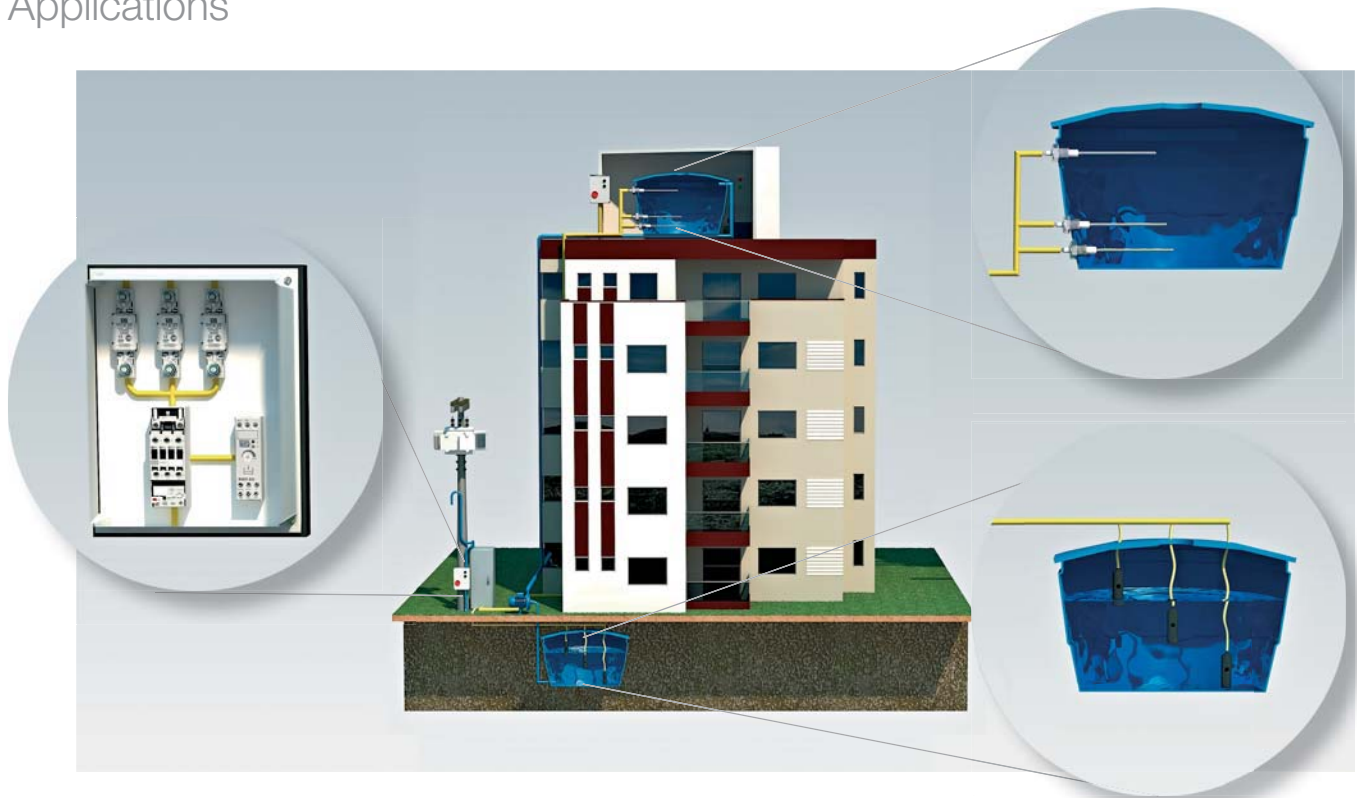

Characteristics

Sensitivity Adjustment

Liquid resistance can vary according to the resistance of the liquid in question and the position of the electrodes. To adapt the relay electronic circuit to the liquid used, sensitivity must be adjusted through the DIAL, located in the front part of the RNW, which has a graded scale without values.

To perform the sensitivity adjustment, all electrodes must be submersed in the reservoir liquid and the DIAL positioned at its limit anti-clockwise (less resistance). With the relay energized the DIAL must be turned clockwise (greater resistance) until the relay output switches its contacts (the red LED must change status). To confirm the adjustment, the reference electrode C must be disconnected and then quickly reconnected, the relay must return to its previous status of de-energization. If this not happen, a new adjustment must be performed. By doing this the RNW does will be adjusted to the ideal sensitivity point.

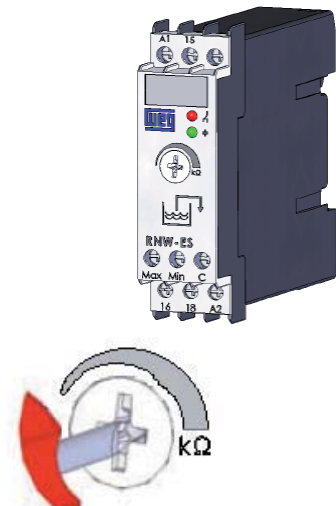

Relay Light Indications

The RNW Level Relay is equipped with indicator LEDs as shown on the right:

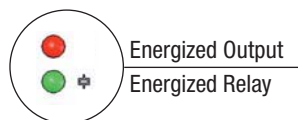

Electronic Relays - Accessories

Adaptor for screw fixing - PLMP

For fixing relay on mounting board using screws.



Dimensions

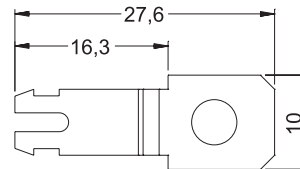

Shaft electrode - EHW



Dimensions

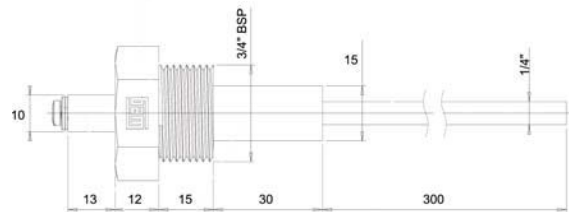

Teflon coated stainless steel shaft
 1 1/4" chrome hex screw
 Length: 300 mm
 Note: Other lengths on request

Pendulum electrode - EPW



Dimensions

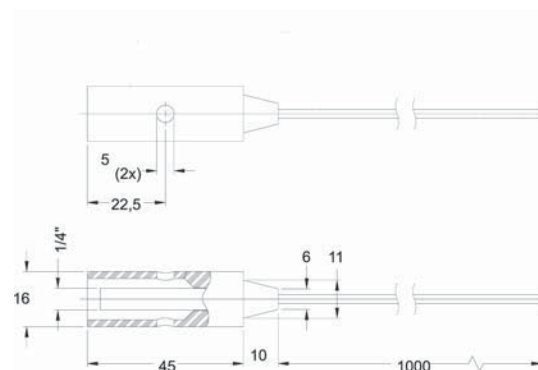

Body in natural black polypropylene
 Stainless steel sensor shaft
 1x10 mm² gauge flexible connection cable
 Cable length: 1000 mm

RTW Technical Data

	Reference Code	RTW	
	Inputs	Rated Insulation Voltage	V
Supply Voltage (U _e)		A1-A2	VAC 24-240VAC/VDC (50/60Hz) 220-240V. 24-240VAC/VDC (50/60Hz) 24VDC. 24-240VAC/VDC (50/60Hz) 380-440V. 24-240VAC/VDC (50/60Hz)
			A2-A3
Control (U _c) (Only RTW RD)		A2-B1	VAC 24-240VAC/VDC (50/60Hz)
Voltage limits			0.85...1.1 x U _c for VAC 0.8...1.25 x U _c for VAC
Consumption			mA 35 for U _e = 24VDC 65 for U _e = 110VAC 75 for U _e = 130VAC 55 for U _e = 220VAC 60 for U _e = 240VAC
Time Adjust		Minimum Time for Reset	ms
	Minimum ON Time (for RTW RD)	ms	50
	Setting Accuracy (as % of the full scale value)	%	+/- 5
	Repeat Accuracy	%	+/- 1
	Changeover time Y - Δ	ms	100
Outputs	Output contacts capacity (I _c)	A	AC-15 in 230 VAC 3 DC-13 in 24 VDC 1 DC-13 in 48 VDC 0.45 DC-13 in 60 VDC 0.35 DC-13 in 125 VDC 0.2 DC-13 in 250 VDC 0.1 A300: AC-15 R300: DC-13
	Rated Thermal Current (I _m)		A 10 (for AC) 2.5 (for DC)
	Fuse (class gL/gG)		A 4
	Mechanical lifespan		operating cycles 30 x 10 ⁶
Characteristics	Ambient Temperature		
	- Operation	°C	-5 to +60
	- Storage	°C	-40 to +85
	Degree of Protection		IP20
	Connection Section (min. to max)	mm ² mm ² A AWG	1 x (0.5 to 2.5) 2 x (0.5 to 2.5)
	- Cable without end sleeve		1 x (0.5 to 2.5) 2 x (0.5 to 2.5)
	- Cable with end sleeve		2 x (20 to 16)
	- AWG-Wire		
	Tightening Torque	N.m lb.in.	0.8 to 1.2 7 to 10.6
	Terminal Screw		M3
	Assembly Position		Any
	Shock Resistance	g/ms	15/11
Resistance Vibration	Hz/mm	10 to 500/10	
Weight	kg	0.08 (1E) 0.095 (2E)	

RPW Technical Data

	Reference Code		RPW FF	RPW SF	RPW FSF	RPW SS	RPW PTC	
	Inputs	Supply (Us)	L1 - L2 - L3	VAC		Voltage ranges (220 up to 480 (select))		24...240VAC/VDC
Frequency			Hz		50/60			
Sensitivity Adjustment			%	70 to 90	-	70 to 90	-/+3 to 15%	-
Operation Limits			%Us	0.85 to 1.1 x Us for VAC				
Maximum Consumption			mA	80				
Maximum voltage allowed in Neutral			V	20	-	20	-	-
Scale Precision (scale base)			%	+ / - 20		-	-	-
Repeatability Precision			%	+ / - 1		-	-	-
Outputs	Maximum Capacity of Output Contacts (Ie)	Resistive Load			5			
		AC-15 (A)			3			
	Fuse (class gL/gG)		A	4				
	Mechanical lifespan		operations	30 x 10 ⁶				
Characteristics	Electrical lifespan		operations	10 x 10 ⁵				
	Ambient Temperature Allowed			-				
	- Operation		°C	-5 to +60				
	- Storage		°C	-40 to +85				
	Degree of Protection			IP 20				
	Terminal Capacity							
	- Wire		mm ²	1 x (0.5 to 2.5)				
				2 x (0.5 to 1.5)				
	- Cable with Terminal		mm ²	1 x (0.5 to 1.5)				
				2 x (0.5 to 1.5)				
	- AWG Solid Conductor		AWG	2 x (20 to 14)				
	Tightening Torque			N.m		0.8 to 1.2		
				lb.in		7 to 10.6		
	Terminal Screw			M3				
	Assembly Position			Any				
	Shock resistance		g/ms	15/11				
Resistance Vibration		Hz/g	10 to 500/10					
Weight		kg	0.1					
Pollution			2					
Overvoltage Category			III					

RNW Technical Data

PRODUCT				RNW ES / RNW EN
Inputs	Supply (Un)	A1	VAC	100-240 50 /60 Hz
		A2	VDC	100-240
	Isolated Rated Voltage (Ui)		V	300
	Operating Limits			0.85 to 1.1 x Ue
	Maximum Consumption		VA / W	2 / 1
Outputs	Contacts	15 - 16 / 18		1 SPDT
	Output Contact Capacity (Ie)			5 (resistive load)
	AC-15 in 230 Vca			3
	DC-13 in 24 VDC			1
	DC-13 in 48 VDC			0.45
	DC-13 in 60 VDC		A	0.35
	DC-13 in 125 VDC			0.2
	DC-13 in 250 VDC			0.1
	A300 : AC-15			
	R300 : DC-13			
Rated thermal current (Ith)		A	10 (for AC) 2.5 (for DC)	
Fuse (class gL / gG)		A	4	
Mechanical Lifespan		operations	30 x 10 ⁶	
Characteristics	Temperature	Operation	°C	-5 to +60
		Storage		-40 to +85
	Degree of Protection			IP20
	Terminal Capacity	Rigid or flexible Cable	mm ²	1 x (0.5 to 2.5)
				2 x (0.5 to 1.5)
	Cable with Terminal	Rigid or flexible Cable/Terminal	mm ²	1 x (0.5 to 2.5)
				2 x (0.5 to 1.5)
	Tightening torque	AWG Solid conductor	AWG	2 x (30 to 14)
				N.m
			lb.in	7 to 10.6
	Terminal Screws			M3
	Assembly Position			Any
	Resistance to Impacts		g / ms	15 / 11
	Resistance to Vibration		Hz / mm	10 to 500 / 10
	Weight		kg	0.08
	Pollution			2
	Over voltage category			II
Sensitivity Adjustment		kΩ	0 to 100	
Electrode Voltage		VCA	7	
Detectors	Electrode Current		mA	0.05
	Maximum length of sensor cable		m	100 (Maximum cable capacitance 2.2nF)
	Detector operating temperature	- Shaft	°C	0 to + 260
		- Pendulum		0 to + 60
	Allowable detector pressure	- Shaft	kgf / cm ²	3
		- Pendulum		-
	Detector Weight	- Shaft	kg	0.230
- Pendulum		0.012		

Electronic Relay Technical Data

Dimensions (mm)

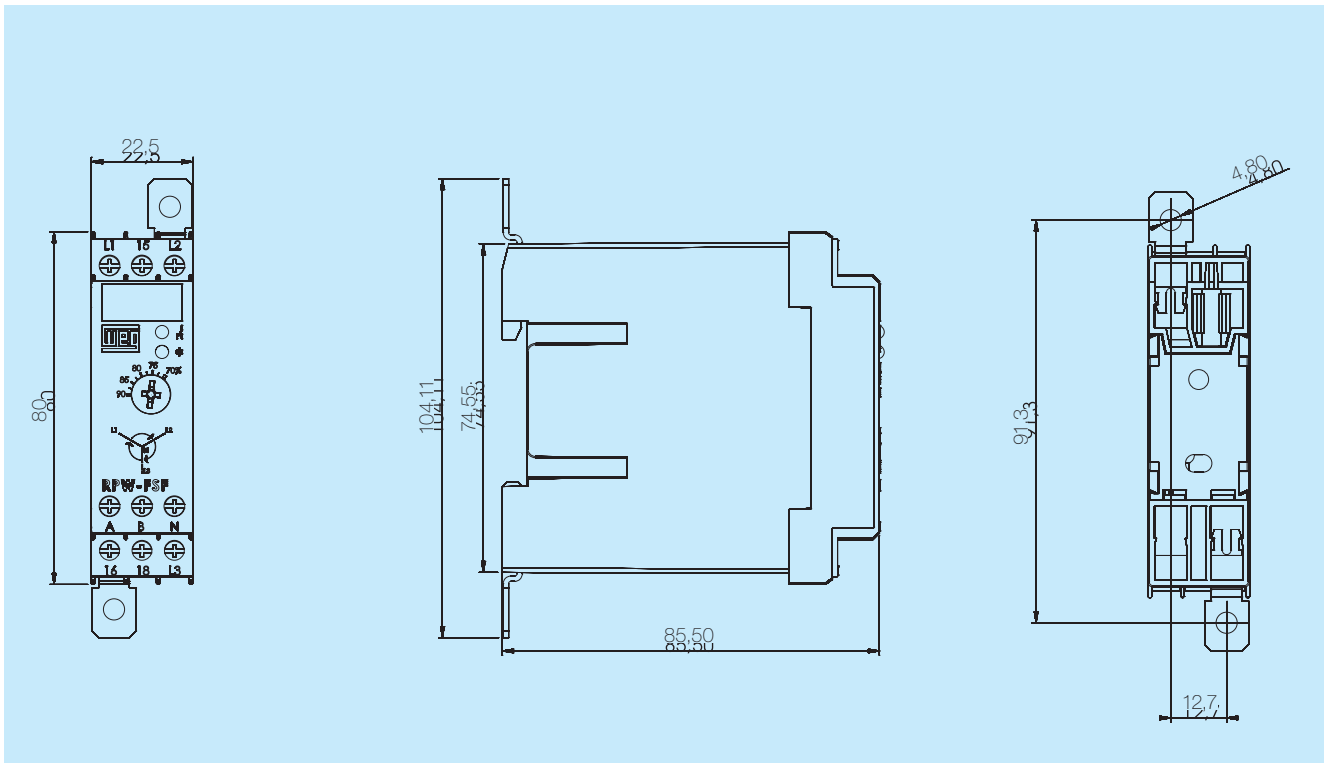

Relay Assembly

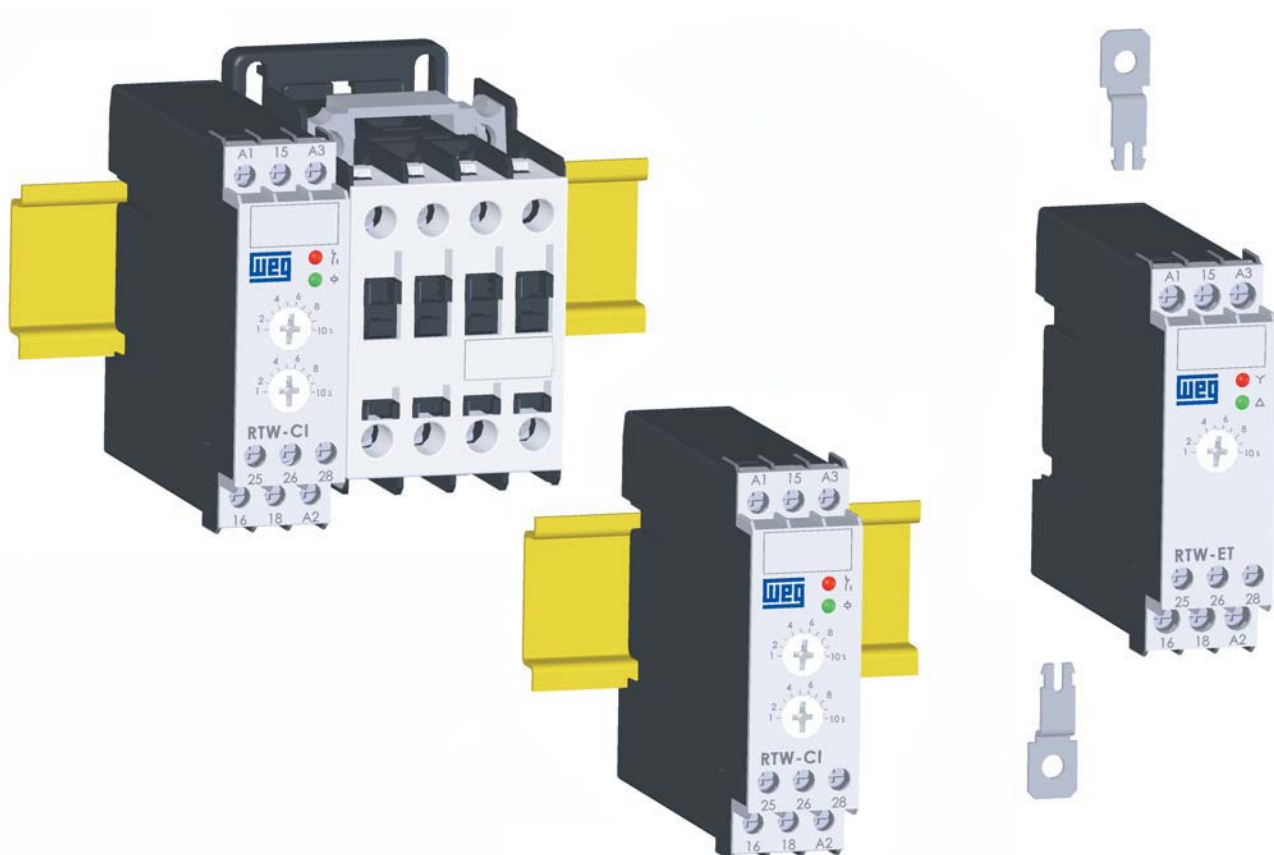

Terminal Blocks

BTW Series

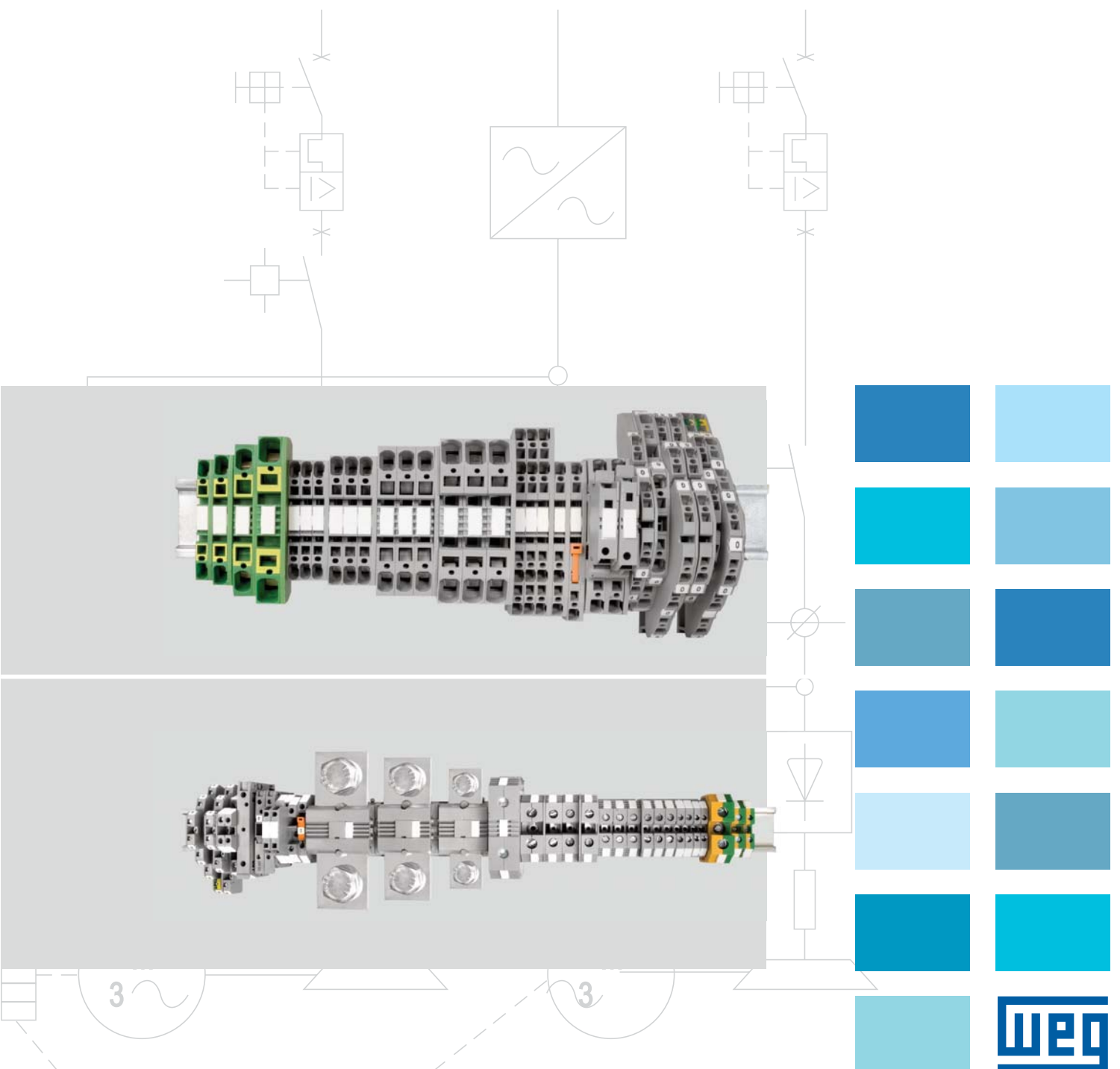

Index - BTWP Series

Standard terminal blocks with screw type connection



BTWP 2,5
pg.151



BTWP 4
pg.151



BTWP 6
pg.151



BTWP 10
pg.152



BTWP 16
pg.152



BTWP 35
pg.152



BTWP 70
pg.152

Power terminal blocks



BTWP 95B
pg.153



BTWP 150B
pg.153



BTWP 240B
pg.153



BTWP 2,5/4T
pg.154



BTWP 6/10T
pg.154



BTWP 16/35T
pg.154

Ground terminal blocks

Double terminal blocks



BTWD 2,5N
pg.155



BTWD 4N
pg.155

Triple terminal blocks



BTWT
pg.155

Double terminal block + ground Triple terminal block + ground Terminal block for detectors Disconnect terminal



BTWT 2T
pg.156



BTWT 3T
pg.156



BTWT 3S
pg.156



BTWS 3A
pg.156

Terminal blocks for fuses



BTWS 2S
pg.157



BTWS 4S
pg.157

1in-2out terminal block



BTWP 4C
pg.157

Index - BTWM Series

Terminal blocks with spring connection

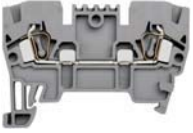

BTWM 2,5
pg.159



BTWM 4
pg.159



BTWM 6
pg.159



BTWM 10
pg.159

Ground terminal blocks



BTWM 2,5T
pg.160



BTWM 4T
pg.160



BTWM 6T
pg.160



BTWM 10T
pg.160

Double terminal blocks



BTWM 2F
pg.161



BTWM 4-2F
pg.161

Triple terminal blocks



BTWM 2,5-3F
pg.161

Double terminal block + ground Triple terminal block + ground Terminal block for detectors Disconnect terminal



BTWM 2,5-2FT
pg.162



BTWM 2,5-3FT
pg.162



BTWM 3S
pg.162



BTWM 2,5A
pg.163



Terminal blocks for fuses



BTWM S
pg.163



BTWM I
pg.163

1in-2out terminal block



BTWM 2E
pg.154

2in-2out terminal block

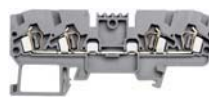

BTWM 2,5C
pg.164

Double earth terminal block



BTWM 2,5CT
pg.164

Presentation

Terminal Blocks

Terminal blocks are devices designed to provide a safe means of electrical and mechanical connection to the majority of the electrical conductors. Among all available connectors, terminal blocks are the most commonly used due to their specific characteristics:

Modularity

All terminal block models are designed to side by side assembly, ensuring the best use of space within the panels.

Easy installation

They can be quickly and easily assembled on DIN rail reducing panel assembly time.



Available in two versions

Screw and spring type connection system.

Wide range of accessories

Connecting bridges, identifiers, DIN rail, end plate and end bracket.

Screw connection

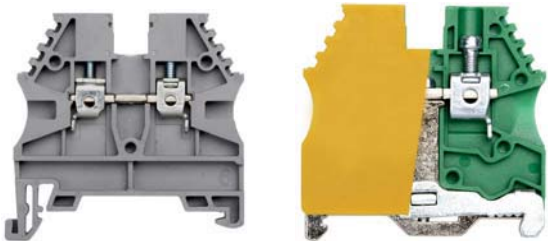

Connecting bridges



Identifiers

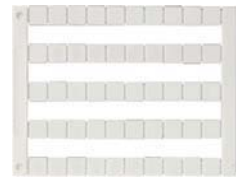
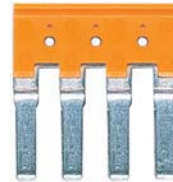

Spring connection



DIN rail



End plate



End brackets



Applications

Terminal blocks can be used on several applications, in the most of the industrial segments. The following examples stand out.

Starters / Control panels

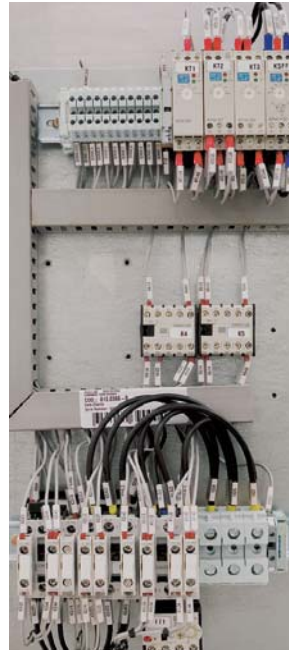

MCCs

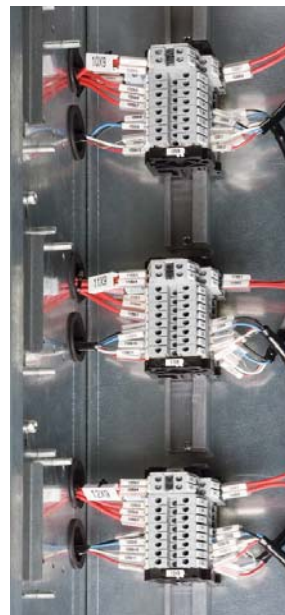

BTWP Series

The BTWP series terminal blocks use screw type connection technique which is the most popular among all known connections. It is simple to use: remove the isolation from the conductor, insert the conductor into the terminal block and tighten the screw with a properly screwdriver. The length of the isolation to be removed and the tightening torque for each terminal block model is shown in the selection guides.

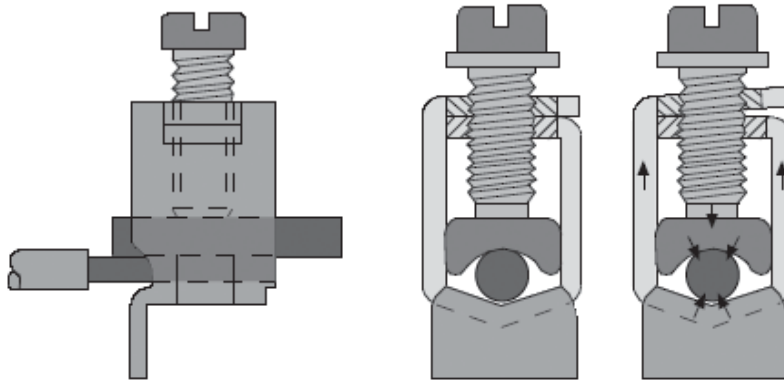

When the screw is tightened, the resulting pressure causes a deformation in the terminal which locks the screw preventing it from loosening. This system ensures connection and quality with minimum electrical losses.





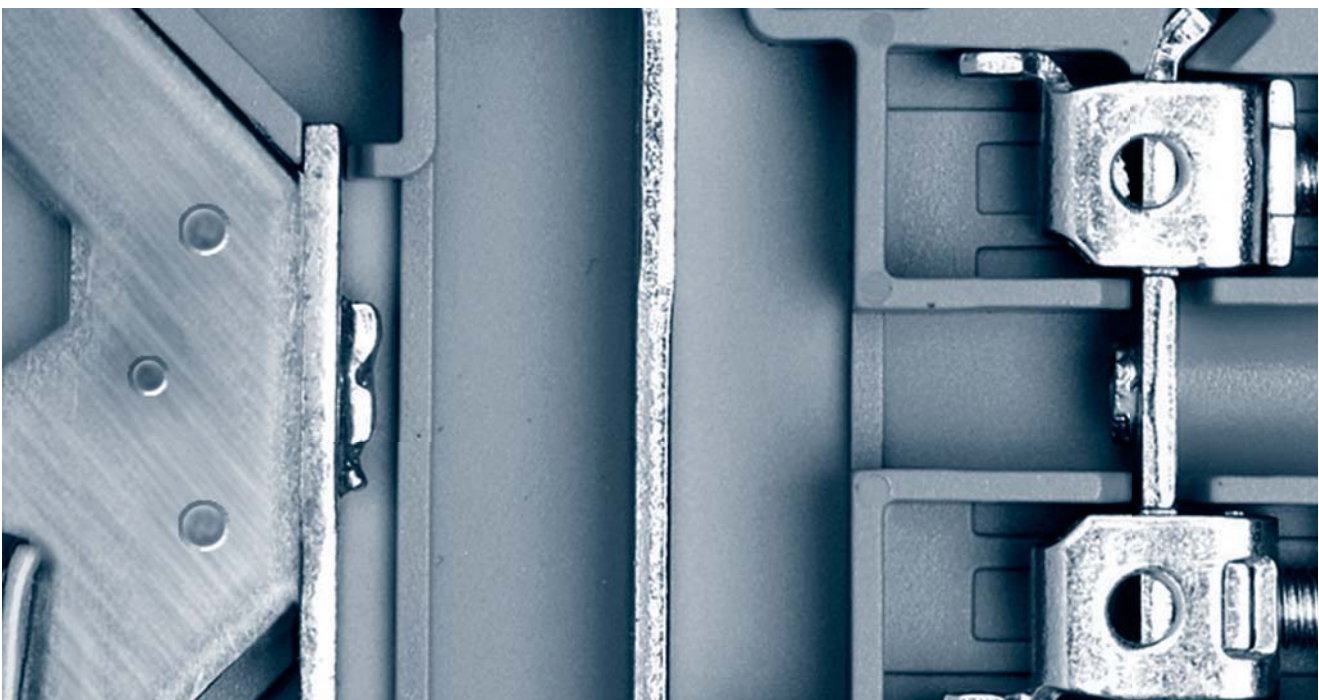



Main features of the BTWP series terminal blocks

- Terminal block body in PA66 polyamide, with excellent dielectric properties and high mechanical resistance
- Internal conductor element with high current conduction capacity.
- Inlet tapered type cable for easy insertion.
- Unlosable terminal screws.



Selection Guide



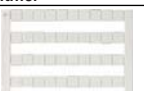







BTWP Series - Terminal blocks with screw connection terminals

		BTWP 2.5 5 mm width 	BTWP 4 6 mm width 	BTWP 6 8 mm width 			
Technical data	Voltage / Current / Cross section	Voltage / Current / Cross section	Voltage / Current / Cross section	Voltage / Current / Cross section			
IEC 60947-7-1	750 V~ / 24 A / 2.5 mm ²	750 V~ / 32 A / 4 mm ²	630 V~ / 41 A / 6 mm ²				
UL / CSA	600 V~ / 20 A / AWG 26 ... 12	600 V~ / 30 A / AWG 26 ... 10	600 V~ / 50 A / AWG 26 ... 8				
Cable stripping	10 mm	10 mm	12 mm				
Tightening torque	0.4 Nm / 3.54 lb - in	0.5 Nm / 4.42 lb - in	0.8 Nm / 7.08 lb - in				
Connection capacity	Connection capacity	Connection capacity	Connection capacity				
Rigid wire	0.5 ... 4 mm ²	0.5 ... 6 mm ²	0.5 ... 10 mm ²				
Flexible cable	1.5 ... 2.5 mm ²	1.5 ... 4 mm ²	1.5 ... 6 mm ²				
AWG Conductor	26 ... 12	26 ... 10	26 ... 8				
Reference Code	Color	Reference Code	Qty/Pack.	Reference Code	Qty/Pack.	Reference Code	Qty/Pack.
6.6 polyamide	Gray	BTWP 2.5	100	BTWP 4	100	BTWP 6	100
	Blue	BTWP 2.5 (AZ)	100	BTWP 4 (AZ)	100	BTWP 6 (AZ)	100
	Green	BTWP 2.5 (VD)	100	BTWP 4 (VD)	100	BTWP 6 (VD)	100
End plate/ Sep. Board	Color	Reference Code	Qty/Pack.	Reference Code	Qty/Pack.	Reference Code	Qty/Pack.
	Gray	TF-BTWP 2.5-10	100	TF-BTWP 2.5-10	100	TF-BTWP 2.5-10	100
	Blue	TF-BTWP 2.5-10 (AZ)	100	TF-BTWP 2.5-10 (AZ)	100	TF-BTWP 2.5-10 (AZ)	100
	Green	TF-BTWP 2.5-10 (VD)	100	TF-BTWP 2.5-10 (VD)	100	TF-BTWP 2.5-10 (VD)	100
	Color	PD-BTWP 2.5-10	25	PD-BTWP 2.5-10	25	PD-BTWP 2.5-10	25
Separating Plate	Color	Reference Code	Qty/Pack.	Reference Code	Qty/Pack.	Reference Code	Qty/Pack.
	Gray	PS1-BTWP	100	PS1-BTWP	100	PS1-BTWP	100
Connecting bridge	N°. of poles	Reference Code	Qty/Pack.	Reference Code	Qty/Pack.	Reference Code	Qty/Pack.
	2	PC-BTWP 2.5/2	25	PC-BTWP 4/2	25	PC-BTWP 6/2	25
	3	PC-BTWP 2.5/3	20	PC-BTWP 4/3	20	PC-BTWP 6/3	20
	4	PC-BTWP 2.5/4	15	PC-BTWP 4/4	15	PC-BTWP 6/4	15
	10	PC-BTWP 2.5/10	5	PC-BTWP 4/10	5	PC-BTWP 6/10	5
End bracket	Color	Reference Code	Qty/Pack.	Reference Code	Qty/Pack.	Reference Code	Qty/Pack.
	Gray	PF3-BTW	100	PF3-BTW	100	PF3-BTW	100
	Gray	PF4-BTW	100	PF4-BTW	100	PF4-BTW	100
Din rail / Support	Type	Reference Code	Qty/Pack.	Reference Code	Qty/Pack.	Reference Code	Qty/Pack.
	Flat	MR 35x7.5	2 m busbars	MR 35x7.5	2 m busbars	MR 35x7.5	2 m busbars
	Support	ST-BTW	25	ST-BTW	25	ST-BTW	25
Group identifier	Color	Reference Code	Qty/Pack.	Reference Code	Qty/Pack.	Reference Code	Qty/Pack.
	Gray	IG-BTW	50	IG-BTW	50	IG-BTW	50
	Clear	IG22-BTW ⁽¹⁾	25	IG22-BTW ⁽¹⁾	25	IG22-BTW ⁽¹⁾	25
Identifier ⁽²⁾		Reference Code	Qty/Pack.	Reference Code	Qty/Pack.	Reference Code	Qty/Pack.
		IDG10/5-BTW	44	IDG10/6-BTW	36	IDG10/6-BTW	36
		IDB5-BTW	50	IDG10/5-BTW	44	IDG10/5-BTW	44
		IDG6/5-BTW	40	IDB5-BTW	50	IDB5-BTW	50
				IDG6/5-BTW	40	IDG6/5-BTW	40

Note: (1) For assembly on PF4-BTW end bracket.
 (2) Further details about identifiers on page 155.

Selection Guide







BTWP Series - Terminal blocks with screw connection terminals

	BTWP 10 10 mm width 		BTWP 16 12 mm width 		BTWP 35 16 mm width 		BTWP 70 22 mm width 		
Technical data	Voltage / Current / Cross section		Voltage / Current / Cross section		Voltage / Current / Cross section		Voltage / Current		
IEC 60947-7-1	630 V~ / 57 A / 10 mm ²		750 V~ / 76 A / 16 mm ²		750 V~ / 125 A / 35 mm ²		750 V~ / 192 A / 70 mm ²		
UL / CSA	600 V~ / 65 A / AWG 16 ... 6		600 V~ / 85 A / AWG 12 ... 4		600 V~ / 115 A / AWG 10 ... 2		600 V~ / 175 A / AWG 6...2/0		
Cable stripping	12 mm		16 mm		18 mm		20 mm		
Tightening torque	1.2 Nm / 10.62 lb - in		1.2 Nm / 10.62 lb - in		2.5 Nm / 122.12 lb - in		6 Nm / 53.10 lb - in		
Connection capacity	Connection capacity		Connection capacity		Connection capacity		Connection capacity		
Rigid wire	1.5 ... 16 mm ²		1.5 ... 16 mm ²		6 ... 16 mm ²		10 ... 16 mm ²		
Flexible cable	1.5 ... 10 mm ²		1.5 ... 16 mm ²		10 ... 35 mm ²		10 ... 70 mm ²		
AWG Conductor	16 ... 6		12 ... 4		10 ... 2		6 ... 2/0		
Reference Code	Color	Reference Code	Qty/Pack.	Reference Code	Qty/Pack.	Reference Code	Qty/Pack.	Reference Code	Qty/Pack.
6.6 polyamide	Gray	BTWP 10	100	BTWP 16	50	BTWP 35	50	BTWP 70	10
	Blue	BTWP 10 (AZ)	100	BTWP 16 (AZ)	50	BTWP 35 (AZ)	50	BTWP 70 (AZ)	10
	Green	BTWP 10 (VD)	100	BTWP 16 (VD)	50	BTWP 35 (VD)	50	BTWP 70 (VD)	10
End plate/ Separating board 1.5 mm width 	Color	Reference Code	Qty/Pack.	Reference Code	Qty/Pack.				
	Gray	TF-BTWP 2.5-10	100	TF-BTWP 16	100	-	-	-	-
	Blue	TF-BTWP 2.5-10(AZ)	100	TF-BTWP 16(AZ)	100	-	-	-	-
	Green	TF-BTWP 2.5-10(VD)	100	TF-BTWP 16(VD)	100	-	-	-	-
	Gray	PD-BTWP 2.5-10	25	PD-BTWP 16	25	-	-	-	-
Separating board 	Color	Reference Code	Qty/Pack.						
	Gray	PS1-BTWP	100	-	-	-	-	-	-
Connecting bridge 	N° of poles	Reference Code	Qty/Pack.	Reference Code	Qty/Pack.	Reference Code	Qty/Pack.		
	2	PC-BTWP 10/2	25	PC-BTWP 16/2	25	PC-BTWP 35/2	25		
	3	PC-BTWP 10/3	20	PC-BTWP 16/3	20	PC-BTWP 35/3	20		
	4	PC-BTWP 10/4	15	PC-BTWP 16/4	15	PC-BTWP 35/4	15		
	10	PC-BTWP 10/10	5	PC-BTWP 16/10	5	PC-BTWP 35/10	5		
End bracket 8 mm width 	Color	Reference Code	Qty/Pack.	Reference Code	Qty/Pack.	Reference Code	Qty/Pack.	Reference Code	Qty/Pack.
	Gray	PF3-BTW	100	PF3-BTW	100	PF3-BTW	100	PF3-BTW	100
	Gray	PF4-BTW	100	PF4-BTW	100	PF4-BTW	100	PF4-BTW	100
Din rail / Support Din EN 50022 	Type	Reference Code	Qty/Pack.	Reference Code	Qty/Pack.	Reference Code	Qty/Pack.	Reference Code	Qty/Pack.
	Flat	MR 35x7.5	2 m bus bars	MR 35x7.5	2 m bus bars	MR 35x7.5	2 m bus bars	MR 35x7.5	2 m bus bars
	Support	ST-BTWw	25	ST-BTW	25	ST-BTW	25	ST-BTW	25
Group identifier 	Color	Reference Code	Qty/Pack.	Reference Code	Qty/Pack.	Reference Code	Qty/Pack.	Reference Code	Qty/Pack.
	Gray	IG-BTW	50	IG-BTW	50	IG-BTW	50	IG-BTW	50
	Clear	IG22-BTW ⁽¹⁾	25	IG22-BTW ⁽¹⁾	25	IG22-BTW ⁽¹⁾	25	IG22-BTW ⁽¹⁾	25
Identifier ⁽²⁾ 		Reference Code	Qty/Pack.	Reference Code	Qty/Pack.	Reference Code	Qty/Pack.	Reference Code	Qty/Pack.
		IDG10/6-BTW	36	IDG10/6-BTW	36	IDG10/6-BTW	36	IDG10/6-BTW	36
		IDG10/5-BTW	44	IDG10/5-BTW	44	IDG10/5-BTW	44	IDG10/5-BTW	44
		IDB5-BTW	50	IDB5-BTW	50	IDB5-BTW	50	IDB5-BTW	50
		IDG6/5-BTW	40	IDG6/5-BTW	40	IDG6/5-BTW	40	IDG6/5-BTW	40

Note: (1) For assembly on PF4-BTW and bracket.
(2) Further information about identifiers on page 155.

Selection Guide



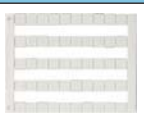





BTWP Series - Power terminal blocks

		BTWP 95B 40 mm width 	BTWP 150B 48 mm width 	BTWP 240B 53 mm width 			
Technical data		Voltage / Current / Cross section	Voltage / Current / Cross section	Voltage / Current / Cross section			
IEC 60947-7-1		1000 V~ / 232 A / 95 mm ²	1000 V~ / 309 A / 150 mm ²	1000 V~ / 415 A / 240 mm ²			
Screw		M10x30	M12x30	M16x35			
Tightening torque		6 Nm / 53.10 lb - in	8 Nm / 70.80 lb - in	10 Nm / 88.50 lb - in			
Reference Code	Color	Reference Code	Qty/Pack.	Reference Code	Qty/Pack.	Reference Code	Qty/Pack.
	Gray	BTWP 95B	4	BTWP 150B	4	BTWP 240B	4
Isolation cover	Color	Reference Code	Qty/Pack.	Reference Code	Qty/Pack.	Reference Code	Qty/Pack.
	Gray	TI-BTWP 95	4	TI-BTWP 150	4	TI-BTWP 240	4
Din rail / Support	Type	Reference Code	Qty/Pack.	Reference Code	Qty/Pack.	Reference Code	Qty/Pack.
DIN EN 50022	Flat	MR 35x7.5	2 m bus bars	MR 35x7.5	2 m bus bars	MR 35x7.5	2 m bus bars
	Support	ST-BTW	25	ST-BTW	25	ST-BTW	25
Group identifier	Color	Reference Code	Qty/Pack.	Reference Code	Qty/Pack.	Reference Code	Qty/Pack.
	Gray	IG-BTW	50	IG-BTW	50	IG-BTW	50
Identifier ⁽²⁾		Reference Code	Qty/Pack.	Reference Code	Qty/Pack.	Reference Code	Qty/Pack.
		IDG10/6-BTW	36	IDG10/6-BTW	36	IDG10/6-BTW	36
		IDG10/5-BTW	44	IDG10/5-BTW	44	IDG10/5-BTW	44
		IDB5-BTW	50	IDB5-BTW	50	IDB5-BTW	50
		IDG6/5-BTW	40	IDG6/5-BTW	40	IDG6/5-BTW	40

Note: (1) Further details about identifiers on page 155.

Selection Guide









BTWP Series - Ground terminal blocks

		BTWP 2.5/4T 6 mm width 		BTWP 6/10T 10 mm width 		BTWP 16/35T 16 mm width 	
							
Technical data		Cross section		Cross section		Cross section	
IEC 60947-7-1		4 mm ²		10 mm ²		35 mm ²	
UL / CSA		AWG 26 ... 10		AWG 16 ... 8		-	
Cable stripping		10 mm		12 mm		18 mm	
Tightening torque		0.5 Nm / 4.42 lb - in		1.2 Nm / 10.62 lb - in		2.5 Nm / 22.12 lb - in	
Connection capacity		Connection capacity		Connection capacity		Connection capacity	
Rigid wire		0.5 ... 6 mm ²		1.5 ... 16 mm ²		6 ... 16 mm ²	
Flexible cable		1.5 ... 4 mm ²		1.5 ... 10 mm ²		10 ... 35 mm ²	
AWG conductor		26 ... 10		16 ... 8		10 ... 2	
Reference Code	Color	Reference Code	Qty/Pack.	Reference Code	Qty/Pack.	Reference Code	Qty/Pack.
6.6 polyamide	Vd/Am	BTWP 2.5/4T	50	BTWP 6/10T	25	BTWP 16/35T	25
Din rail / Support	Type	Reference Code	Qty/Pack.	Reference Code	Qty/Pack.	Reference Code	Qty/Pack.
	Flat	MR 35x7.5	2 m bus bars	MR 35x7.5	2 m bus bars	MR 35x7.5	2 m bus bars
	Support	ST-BTW	25	ST-BTW	25	ST-BTW	25
Group identifier	Color	Reference Code	Qty/Pack.	Reference Code	Qty/Pack.	Reference Code	Qty/Pack.
	Gray	IG-BTW	50	IG-BTW	50	IG-BTW	50
Identifier ⁽²⁾	Reference Code	Qty/Pack.	Reference Code	Qty/Pack.	Reference Code	Qty/Pack.	
	IDG10/6-BTW	36	IDG10/6-BTW	36	IDG10/6-BTW	36	
	IDG10/5-BTW	44	IDG10/5-BTW	44	IDG10/5-BTW	44	
	IDB5-BTW	50	IDB5-BTW	50	IDB5-BTW	50	
	IDG6/5-BTW	40	IDG6/5-BTW	40	IDG6/5-BTW	40	

Note: (1) Further details about identifiers on page 155.

Selection Guide

BTWP / BTWT Series - double terminal blocks and triple terminal blocks

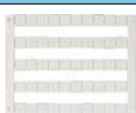









		BTWD 2.5N 5 mm width 		BTWD 4N 6 mm width 		BTWT 3 6 mm width 	
		CE cRU ^{us}		CE cRU ^{us}		CE cRU ^{us}	
Technical data		Voltage / Current / Cross section		Voltage / Current / Cross section		Voltage / Current / Cross section	
IEC 60947-7-1		500 V~ / 24 A / 2.5 mm ²		500 V~ / 32 A / 4 mm ²		440 V~ / 24 A / 2.5 mm ²	
UL / CSA		300 V~ / 20 A / AWG 26 ... 12		300 V~ / 30 A / AWG 26 ... 10		300 V~ / 24 A / AWG 24 ... 12	
Cable stripping		9 mm		9 mm		9 mm	
Tightening torque		0.4 Nm / 13.54 lb - in		0.5 Nm / 14.42 lb - in		0.4 Nm / 13.54 lb - in	
Connection capacity		Connection capacity		Connection capacity		Connection capacity	
Rigid wire		0.5 ... 4 mm ²		0.5 ... 6 mm ²		0.5 ... 4 mm ²	
Flexible cable		1.5 ... 2.5 mm ²		1.5 ... 4 mm ²		1.5 ... 2.5 mm ²	
AWG Conductor		26 ... 12		26 ... 10		24 ... 12	
Reference Code	Color	Reference Code	Qty/Pack.	Reference Code	Qty/Pack.	Reference Code	Qty/Pack.
	Gray	BTWD 2.5N	100	BTWD 4N	100	BTWT 3	25
End plate	Color	Reference Code	Qty/Pack.	Reference Code	Qty/Pack.	Reference Code	Qty/Pack.
1.5 mm wic 	Gray	TF-BTWD 2.5-4N	25	TF-BTWD 2.5-4N	25	TF-BTWT 3	10
Separating Plate	Color					Reference Code	Qty/Pack.
	Gray	-		-		PS1-BTWP	100
Connecting bridge	N°. of poles	Reference Code	Qty/Pack.	Reference Code	Qty/Pack.	Reference Code	Qty/Pack.
	2	PC-BTWP 2.5/2	25	PC-BTWP 4/2	25	PC-BTWT 2.5/2	25
	3	PC-BTWP 2.5/3	20	PC-BTWP 4/3	20	PC-BTWT 2.5/3	20
	4	PC-BTWP 2.5/4	15	PC-BTWP 4/4	15	PC-BTWT 2.5/4	15
	10	PC-BTWP 2.5/10	5	PC-BTWP 4/10	5	PC-BTWT 2.5/10	5
End bracket	Color	Reference Code	Qty/Pack.	Reference Code	Qty/Pack.	Reference Code	Qty/Pack.
8 mm width 	Gray	PF3-BTW	100	PF3-BTW	100	PF3-BTW	100
	Gray	PF4-BTW	100	PF4-BTW	100	PF4-BTW	100
Din rail / Support	Type	Reference Code	Qty/Pack.	Reference Code	Qty/Pack.	Reference Code	Qty/Pack.
DIN EN 50022 	Smooth	MR 35x7.5	2 m bus bars	MR 35x7.5	2 m bus bars	MR 35x7.5	2 m bus bars
	Supoort	ST-BTW	25	ST-BTW	25	ST-BTW	25
Identifier group	Color	Reference Code	Qty/Pack.	Reference Code	Qty/Pack.	Reference Code	Qty/Pack.
	Gray	IG-BTW	50	IG-BTW	50	IG-BTW	50
	Clear	IG22-BTW ⁽¹⁾	25	IG22-BTW ⁽¹⁾	25	IG22-BTW ⁽¹⁾	25
Identifier ⁽²⁾		Reference Code	Qty/Pack.	Reference Code	Qty/Pack.	Reference Code	Qty/Pack.
		IDG10/5-BTW	44	IDG10/6-BTW	36	IDB5-BTW	50
		IDB5-BTW	50	IDG10/5-BTW	44		
		IDG6/5-BTW	40	IDB5-BTW	50		
				IDG6/5-BTW	40		

Note: (1) For assembly on PF4-BTW end bracket.

(2) Further information about identifiers on page 155

Selection Guide

BTWP / BTWS Series - Double terminal block + ground - triple terminal block + ground - terminal block for detectors - disconnect terminal







		BTWT 2T 6 mm width 	BTWT 3T 6 mm width 	BTWT 3S 6 mm width 	BTWS 3A 6 mm width 
Technical data		Voltage / Current / Cross Section	Voltage / Current / Cross Section	Voltage / Current / Cross Section	Voltage / Current / Cross Section
IEC 60947-7-1		440 V~ / 24 A / 2.5 mm ²	440 V~ / 24 A / 2.5 mm ²	500 V~ / 24 A / 2.5 mm ²	500 V~ / 16 A / 4 mm ²
UL / CSA		300 V~ / 24 A / AWG 24 ... 12	300 V~ / 24 A / AWG 24 ... 12	-	600 V~ / 16 A / AWG 26...10
Cable stripping		9 mm	9 mm	9 mm	10 mm
Tightening torque		0.4 Nm / 13.54 lb - in	0.4 Nm / 13.54 lb - in	0.4 Nm / 13.54 lb - in	0.5 Nm / 4.42 lb - in
Connection capacity		Connection capacity	Connection capacity	Connection capacity	Connection capacity
Rigid wire		0.5 ... 4 mm ²	0.5 ... 4 mm ²	0.5 ... 4 mm ²	0.5 ... 6 mm ²
Flexible cable		1.5 ... 2.5 mm ²	1.5 ... 2.5 mm ²	1.5 ... 2.5 mm ²	1.5 ... 4 mm ²
AWG Conductor		24 ... 12	24 ... 12	24 ... 12	26 ... 10
Reference Code	Color	Reference Code	Qty/Pack.	Reference Code	Qty/Pack.
	Gray	BTWT 2T	25	BTWT 3T	25
	Gray	BTWT 3S	20	BTWS 3A	20
End plate / Separating board	Color	Reference Code	Qty/Pack.	Reference Code	Qty/Pack.
1.5 mm width 	Gray	TF-BTWT 2T	10	TF-BTWT 3T	10
	Gray	TF-BTWT 3S	10	TF-BTWS 3	10
Separating plate	Color	Reference Code	Qty/Pack.	Reference Code	Qty/Pack.
	Gray	PS1-BTWP	100	PS1-BTWP	100
	Gray	PS1-BTWP	100	PS1-BTWP	100
Conneting bridge	No.Poles	Reference Code	Qty/Pack.	Reference Code	Qty/Pack.
	2	PC-BTWT 2.5/2	25	PC-BTWT 2.5/2	25
	3	PC-BTWT 2.5/3	20	PC-BTWT 2.5/3	20
	4	PC-BTWT 2.5/4	15	PC-BTWT 2.5/4	15
	10	PC-BTWT 2.5/10	5	PC-BTWT 2.5/10	5
	10	PC-BTWT 2.5/10	5	PC-BTWT 2.5/10	5
	5	PC-BTWT 2.5/5	10	PC-BTWT 2.5/5	10
End bracket	Color	Reference Code	Qty/Pack.	Reference Code	Qty/Pack.
8 mm width 	Gray	PF3-BTW	100	PF3-BTW	100
	Gray	PF4-BTW	100	PF4-BTW	100
	Gray	PF4-BTW	100	PF4-BTW	100
	Gray	PF4-BTW	100	PF4-BTW	100
Rail / Support	Type	Reference Code	Qty/Pack.	Reference Code	Qty/Pack.
Din EN 50022 	Flat	MR 35x7.5	2 m busbars	MR 35x7.5	2 m busbars
	Flat	MR 35x7.5	2 m busbars	MR 35x7.5	2 m busbars
	Support	ST-BTW	25	ST-BTW	25
	Support	ST-BTW	25	ST-BTW	25
	Support	ST-BTW	25	ST-BTW	25
	Support	ST-BTW	25	ST-BTW	25
Identifier group	Color	Reference Code	Qty/Pack.	Reference Code	Qty/Pack.
	Gray	IG-BTW	50	IG-BTW	50
	Clear	IG22-BTW ⁽¹⁾	25	IG22-BTW ⁽¹⁾	25
	Clear	IG22-BTW ⁽¹⁾	25	IG22-BTW ⁽¹⁾	25
	Clear	IG22-BTW ⁽¹⁾	25	IG22-BTW ⁽¹⁾	25
Identifier ⁽²⁾		Reference Code	Qty/Pack.	Reference Code	Qty/Pack.
		IDB5-BTW	50	IDB5-BTW	50
		IDB5-BTW	50	IDB5-BTW	50
		IDB5-BTW	50	IDB5-BTW	50
		IDB5-BTW	50	IDB5-BTW	50
				IDG10/6-BTW	36
				IDG10/5-BTW	44
				IDB5-BTW	50
				IDG6/5-BTW	40

Note: (1) For assembly on PF4-BTW end bracket.

(2) Further information about identifiers on page 155

Selection Guide

BTWS / BTWP Series - Terminal blocks for fuses - 1IN-2OUT terminal block

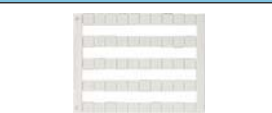
		BTWS 2S 8 mm width		BTWS 4S 10 mm width		BTWP 4C 6 mm width	
							
Technical data		Voltage / Current / Cross section		Voltage / Current / Cross section		Voltage / Current / Cross section	
IEC 60947-7-1		500 V~ / 6.3 A / 6 mm ²		750 V~ / 6.3 A / 6 mm ²		750 V~ / 32 A / 4 mm ²	
UL / CSA		300 V~ / 6.3 A / AWG 26 ... 8		600 V~ / 6.3 A / AWG 22 ... 8		-	
Fuse dimensions		5x20 ou 5x25 mm		6.35x31.75 mm (1/4"x1 1/4")		-	
Cable stripping		12 mm		12 mm		10 mm	
Tightening torque		0.8 Nm / 7.08 lb - in		0.8 Nm / 7.08 lb - in		0.5 Nm / 4.42 lb - in	
Connection capacity		Connection capacity		Connection capacity		Connection capacity	
Rigid wire		0.5 ... 10 mm ²		0.5 ... 10 mm ²		0.5 ... 6 mm ²	
Flexible cable		1.5 ... 6 mm ²		1.5 ... 6 mm ²		1.5 ... 4 mm ²	
AWG Conductor		26 ... 8		22 ... 8		26 ... 10	
Reference Code	Color	Reference Code	Qty/Pack.	Reference Code	Qty/Pack.	Reference Code	Qty/Pack.
	Gray	BTWS 2S	50	BTWS 4S	20	BTWP 4C	50
				Note! Accept reserve fuse disconnect lever.			
End plate	Color	Reference Code	Qty/Pack.	Reference Code	Qty/Pack.	Reference Code	Qty/Pack.
1.5 mm width	Gray	TF-BTWS 2	10	Supplied with end plate as standard		TF-BTWP 4C	10
							
End bracket	Color	Reference Code	Qty/Pack.	Reference Code	Qty/Pack.	Reference Code	Qty/Pack.
8 mm width	Gray	PF3-BTW	100	PF3-BTW	100	PF3-BTW	100
							
	Gray	PF4-BTW	100	PF4-BTW	100	PF4-BTW	100
Rail / Support	Type	Reference Code	Qty/Pack.	Reference Code	Qty/Pack.	Reference Code	Qty/Pack.
DIN EN 50022	Flat	MR 35x7.5	2 m busbars	MR 35x7.5	2 m busbars	MR 35x7.5	de 2 m busbars
							
	Support	ST-BTW	25	ST-BTW	25	ST-BTW	25
Group identifier	Color	Reference Code	Qty/Pack.	Reference Code	Qty/Pack.	Reference Code	Qty/Pack.
							
	Gray	IG-BTW	50	IG-BTW	50	IG-BTW	50
	Clear	IG22-BTW ⁽¹⁾	25	IG22-BTW ⁽¹⁾	25	IG22-BTW ⁽¹⁾	25
Identifier ⁽²⁾		Reference Code	Qty/Pack.	Reference Code	Qty/Pack.	Reference Code	Qty/Pack.
							
		IDB5-BTW	50	IDG10/6-BTW	36	IDG10/6-BTW	36
				IDG10/5-BTW	44	IDG10/5-BTW	44
				IDB5-BTW	50	IDB5-BTW	50
				IDG6/5-BTW	40	IDG6/5-BTW	40

Note: (1) For assembly on PF4-BTW end bracket.
(2) Further details about identifiers on page 155.

BTWM Series

The BTWM series terminal blocks use spring connection technique products. The connection is maintained through a stainless steel spring which keeps constant pressure on the conductor against the internal copper part.

The connection procedure is simple: Remove conductor isolation, insert a screwdriver into the square opening in the terminal block to compress the spring and release the access and then insert the conductor into the terminal block. When removing the screwdriver, the connection becomes effective. The contact pressure in this connection system is uniform and independent of user/operator, as it is provided by the spring.

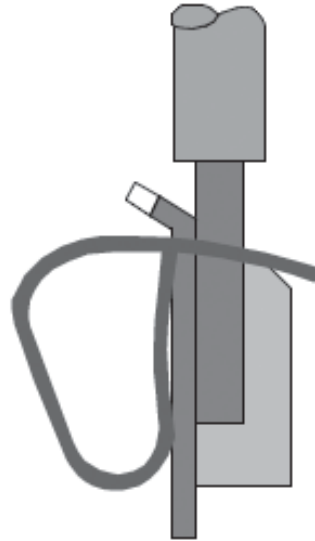





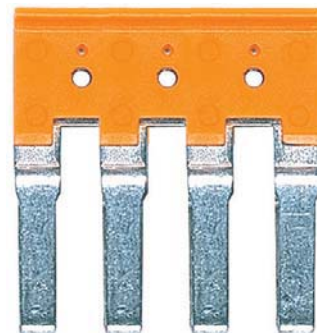





Main features of the BTWM series terminal blocks:

- Terminal block body in PA66 polyamide, with excellent dielectric properties and high mechanical resistance.
- Internal conductor element with high current conduction capacity.
- Stainless steel spring.
- Uniform contact pressure.



Selection guide









BTWM series - Spring clamp terminals

		BTWM 2.5 5 mm width 		BTWM 4 6 mm width 		BTWM 6 8 mm width 		BTWM 10 10 mm width 	
Technical data		Voltage / Current / Cross section		Voltage / Current / Cross section		Voltage / Current / Cross section		Voltage / Current / Cross section.	
IEC 60947-7-1		750 V~ / 24 A / 2.5 mm ²		750 V~ / 32 A / 4 mm ²		750 V~ / 41 A / 6 mm ²		750 V~ / 57 A / 10 mm ²	
UL / CSA		600 V~ / 20 A / AWG 22 ... 12		600 V~ / 26 A / AWG 22 ... 10		600 V~ / 35 A / AWG 22 ... 8		600 V~ / 55 A / AWG 20 ... 6	
Cable stripping		10 mm		12 mm		12 mm		13 mm	
Connection capacity		Connection capacity		Connection capacity		Connection capacity		Connection capacity	
Rigid wire		0.5 ... 4 mm ²		0.5 ... 6 mm ²		0.5 ... 10 mm ²		0.5 ... 16 mm ²	
Flexible cable		0.5 ... 2.5 mm ²		0.5 ... 4 mm ²		0.5 ... 6 mm ²		0.5 ... 10 mm ²	
AWG Conductor		22...12		22...10		22...8		20...6	
Reference Code	Color	Reference Code	Qty/Pack.	Reference Code	Qty/Pack.	Reference Code	Qty/Pack.	Reference Code	Qty/Pack.
6.6 polyamide	Gray	BTWM 2.5	100	BTWM 4	100	BTWM 6	100	BTWM 10	100
	Blue	BTWM 2.5 (AZ)	100	BTWM 4 (AZ)	100	BTWM 6 (AZ)	100	BTWM 10 (AZ)	100
	Green	BTWM 2.5 (VD)	100	BTWM 4 (VD)	100	BTWM 6 (VD)	100	BTWM 10 (VD)	100
End plate	Color	Reference Code	Qty/Pack.	Reference Code	Qty/Pack.	Reference Code	Qty/Pack.	Reference Code	Qty/Pack.
1.2 mm width 	Gray	TF-BTWM 2.5	100	TF-BTWM 4	100	TF-BTWM 6	100	TF-BTWM 10	100
	Blue	TF-BTWM 2.5 (AZ)	100	TF-BTWM 4 (AZ)	100	TF-BTWM 6 (AZ)	100	TF-BTWM 10 (AZ)	100
	Green	TF-BTWM 2.5 (VD)	100	TF-BTWM 4 (VD)	100	TF-BTWM 6 (VD)	100	TF-BTWM 10 (VD)	100
Connecting bridge	N°. of poles	Reference Code	Qty/Pack.	Reference Code	Qty/Pack.	Reference Code	Qty/Pack.	Reference Code	Qty/Pack.
	2	PC-BTWM 2.5/2	25	PC-BTWM 4/2	25	PC-BTWM 6/2	25	PC-BTWM 10/2	25
	3	PC-BTWM 2.5/3	20	PC-BTWM 4/3	20	PC-BTWM 6/3	20	PC-BTWM 10/3	20
	4	PC-BTWM 2.5/4	15	PC-BTWM 4/4	15	PC-BTWM 6/4	15	PC-BTWM 10/4	15
	10	PC-BTWM 2.5/10	5	PC-BTWM 4/10	5	PC-BTWM 6/10	5	PC-BTWM 10/10	5
End bracket	Color	Reference Code	Qty/Pack.	Reference Code	Qty/Pack.	Reference Code	Qty/Pack.	Reference Code	Qty/Pack.
8 mm width 	Gray	PF3-BTW	100	PF3-BTW	100	PF3-BTW	100	PF3-BTW	100
	Gray	PF4-BTW	100	PF4-BTW	100	PF4-BTW	100	PF4-BTW	100
Rail / Support	Type	Reference Code	Qty/Pack.	Reference Code	Qty/Pack.	Reference Code	Qty/Pack.	Reference Code	Qty/Pack.
Din EN 50022 	Flat	MR 35x7.5	2 m busbars	MR 35x7.5	2 m busbars	MR 35x7.5	2 m busbars	MR 35x7.5	2 m busbars
	Support	ST-BTW	25	ST-BTW	25	ST-BTW	25	ST-BTW	25
Group identifier	Color	Reference Code	Qty/Pack.	Reference Code	Qty/Pack.	Reference Code	Qty/Pack.	Reference Code	Qty/Pack.
	Gray	IG-BTW	50	IG-BTW	50	IG-BTW	50	IG-BTW	50
	Clear	IG22-BTW ⁽¹⁾	25	IG22-BTW ⁽¹⁾	25	IG22-BTW ⁽¹⁾	25	IG22-BTW ⁽¹⁾	25
Identifier ⁽²⁾		Reference Code	Qty/Pack.	Reference Code	Qty/Pack.	Reference Code	Qty/Pack.	Reference Code	Qty/Pack.
		IDG10/5-BTW	44	IDG10/6-BTW	36	IDG10/6-BTW	36	IDG10/6-BTW	36
		IDB5-BTW	50	IDG10/5-BTW	44	IDG10/5-BTW	44	IDG10/5-BTW	44
		IDG6/5-BTW	40	IDB5-BTW	50	IDB5-BTW	50	IDB5-BTW	50
				IDG6/5-BTW	40	IDG6/5-BTW	40	IDG6/5-BTW	40

Note: (1) For assembly on PF4-BTW end bracket.
(2) Further details about identifiers on page 155.

Selection Guide

BTWM Series - Ground terminal blocks

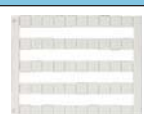







		BTWM 2.5T 5 mm width 		BTWM 4T 6 mm width 		BTWM 6T 8 mm width 		BTWM 10T 10 mm width 	
Technical data		Cross section		Cross section		Cross section		Cross section	
IEC 60947-7-1		2.5 mm ²		4 mm ²		6 mm ²		10 mm ²	
UL / CSA		AWG 22 ... 12		AWG 22 ... 10		AWG 22 ... 8		AWG 20 ... 6	
Cable stripping		10 mm		12 mm		12 mm		13 mm	
Connection capacity		Connection capacity		Connection capacity		Connection capacity		Connection capacity	
Rigid wire		0.5 ... 4 mm ²		0.5 ... 6 mm ²		0.5 ... 10 mm ²		0.5 ... 16 mm ²	
Flexible cable		0.5 ... 2.5 mm ²		0.5 ... 4 mm ²		0.5 ... 6 mm ²		0.5 ... 10 mm ²	
AWG Conductor		22 ... 12		22 ... 10		22 ... 8		20 ... 6	
Reference Code	Color	Reference Code	Qty/Pack.	Reference Code	Qty/Pack.	Reference Code	Qty/Pack.	Reference Code	Qty/Pack.
	Green	BTWM 2.5T	50	BTWM 4T	50	BTWM 6T	40	BTWM 10T	30
End plate	Color	Reference Code	Qty/Pack.	Reference Code	Qty/Pack.	Reference Code	Qty/Pack.	Reference Code	Qty/Pack.
1.2 mm width 	Green	TF-BTWM 2.5 (VD)	10	TF-BTWM 4 (VD)	10	TF-BTWM 6 (VD)	10	TF-BTWM 10 (VD)	10
End bracket	Color	Reference Code	Qty/Pack.	Reference Code	Qty/Pack.	Reference Code	Qty/Pack.	Reference Code	Qty/Pack.
8 mm width 	Gray	PF3-BTW	100	PF3-BTW	100	PF3-BTW	100	PF3-BTW	100
	Gray	PF4-BTW	100	PF4-BTW	100	PF4-BTW	100	PF4-BTW	100
Din Rail / Support	Type	Reference Code	Qty/Pack.	Reference Code	Qty/Pack.	Reference Code	Qty/Pack.	Reference Code	Qty/Pack.
DIN EN 50022 	Flat	MR 35x7.5	2 m busbars	MR 35x7.5	2 m busbars	MR 35x7.5	2 m busbars	MR 35x7.5	2 m busbars
	Support	ST-BTW	25	ST-BTW	25	ST-BTW	25	ST-BTW	25
Group identifier	Color	Reference Code	Qty/Pack.	Reference Code	Qty/Pack.	Reference Code	Qty/Pack.	Reference Code	Qty/Pack.
	Gray	IG-BTW	50	IG-BTW	50	IG-BTW	50	IG-BTW	50
	Clear	IG22-BTW ⁽¹⁾	25	IG22-BTW ⁽¹⁾	25	IG22-BTW ⁽¹⁾	25	IG22-BTW ⁽¹⁾	25
Identifier ⁽²⁾		Reference Code	Qty/Pack.	Reference Code	Qty/Pack.	Reference Code	Qty/Pack.	Reference Code	Qty/Pack.
		IDG10/5-BTW	44	IDG10/6-BTW	36	IDG10/6-BTW	36	IDG10/6-BTW	36
		IDB5-BTW	50	IDG10/5-BTW	44	IDG10/5-BTW	44	IDG10/5-BTW	44
		IDG6/5-BTW	40	IDB5-BTW	50	IDB5-BTW	50	IDB5-BTW	50
				IDG6/5-BTW	40	IDG6/5-BTW	40	IDG6/5-BTW	40

Note: (1) For assembly on PF4-BTW end bracket.

(2) Further details about identifiers on page 155.

Selection Guide

BTWM Series - Double terminal blocks - Triple terminal blocks

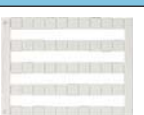







		BTWM 2.5-2F 5 mm width 		BTWM 4-2F 6 mm width 		BTWM 2.5-3F 5 mm width 	
Technical data		Voltage / Current / Cross section		Voltage / Current / Cross section		Voltage / Current / Cross section	
IEC 60947-7-1		500 V~ / 24 A / 2.5 mm ²		750 V~ / 30 A / 4 mm ²		500 V~ / 24 A / 2.5 mm ²	
UL / CSA		600 V~ / 20 A / AWG 22 ... 12		600 V~ / 26 A / AWG 22 ... 10		600 V~ / 20 A / AWG 22 ... 12	
Cable stripping		10 mm		12 mm		10 mm	
Connection capacity		Connection capacity		Connection capacity		Connection capacity	
Rigid wire		0.5 ... 4 mm ²		0.5 ... 6 mm ²		0.5 ... 4 mm ²	
Flexible cable		0.5 ... 2.5 mm ²		0.5 ... 4 mm ²		0.5 ... 2.5 mm ²	
AWG Conductor		22 ... 12		22 ... 10		22 ... 12	
Reference Code	Color	Reference Code	Qty/Pack.	Reference Code	Qty/Pack.	Reference Code	Qty/Pack.
6.6 polyamide	Gray	BTWM 2.5-2F	50	BTWM 4-2F	50	BTWM 2.5-3F	20
End plate 1.5 mm width 	Color	Reference Code	Qty/Pack.	Reference Code	Qty/Pack.	Reference Code	Qty/Pack.
	Gray	TF-BTWM 2.5-2F	50	TF-BTWM 4-2F	25	TF-BTWM 2.5-3F	10
Connecting bridge 	Nº. of poles	Reference Code	Qty/Pack.	Reference Code	Qty/Pack.	Reference Code	Qty/Pack.
	2	PC-BTWM 2.5/2	25	PC-BTWM 4/2	25	PC-BTWM 2.5/2	25
	3	PC-BTWM 2.5/3	20	PC-BTWM 4/3	20	PC-BTWM 2.5/3	20
	4	PC-BTWM 2.5/4	15	PC-BTWM 4/4	15	PC-BTWM 2.5/4	15
	10	PC-BTWM 2.5/10	5	PC-BTWM 4/10	5	PC-BTWM 2.5/10	5
End bracket 8 mm width 	Color	Reference Code	Qty/Pack.	Reference Code	Qty/Pack.	Reference Code	Qty/Pack.
	Gray	PF3-BTW	100	PF3-BTW	100	PF3-BTW	100
	Gray	PF4-BTW	100	PF4-BTW	100	PF4-BTW	100
Rail / Support Din EN 50022 	Type	Reference Code	Qty/Pack.	Reference Code	Qty/Pack.	Reference Code	Qty/Pack.
	Flat	MR 35x7.5	2 m busbars	MR 35x7.5	2 m busbars	MR 35x7.5	2 m busbars
	Support	ST-BTW	25	ST-BTW	25	ST-BTW	25
Identifier group 	Color	Reference Code	Qty/Pack.	Reference Code	Qty/Pack.	Reference Code	Qty/Pack.
	Gray	IG-BTW	50	IG-BTW	50	IG-BTW	50
	Clear	IG22-BTW ⁽¹⁾	25	IG22-BTW ⁽¹⁾	25	IG22-BTW ⁽¹⁾	25
Identifier ⁽²⁾ 		Reference Code	Qty/Pack.	Reference Code	Qty/Pack.	Reference Code	Qty/Pack.
		IDB5-BTW	50	IDG10/6-BTW	36	IDB5-BTW	50
				IDG10/5-BTW	44		
				IDB5-BTW	50		
				IDG6/5-BTW	40		

Note: (1) For assembly on PF4-BTW end bracket.

(2) Further details about identifiers on page 155.

Selection Guide

BTWM Series - Double terminal block + ground - Triple terminal block + ground - Terminal block for detectors









		BTWM 2.5-2FT 5 mm width 	BTWM 2.5-3FT 5 mm width 	BTWM 3S 5 mm width 			
Technical data	Voltage / Current / Cross section	Voltage / Current / Cross section	Voltage / Current / Cross section	Voltage / Current / Cross section			
IEC 60947-7-1	500 V~ / 24 A / 2.5 mm ²	500 V~ / 24 A / 2.5 mm ²	500 V~ / 24 A / 2.5 mm ²	500 V~ / 24 A / 2.5 mm ²			
UL / CSA	600 V~ / 20 A / AWG 22 ... 12	600 V~ / 20 A / AWG 22 ... 12	-	-			
Cable stripping	10 mm	10 mm	10 mm	10 mm			
Connection capacity	Connection capacity	Connection capacity	Connection capacity	Connection capacity			
Rigid wire	0.5 ... 4 mm ²	0.5 ... 4 mm ²	0.5 ... 4 mm ²	0.5 ... 4 mm ²			
Flexible cable	0.5 ... 2.5 mm ²	0.5 ... 2.5 mm ²	0.5 ... 2.5 mm ²	0.5 ... 2.5 mm ²			
AWG Conductor	22 ... 12	22 ... 12	22 ... 12	22 ... 12			
Reference Code	Color	Reference Code	Qty/Pack.	Reference Code	Qty/Pack.	Reference Code	Qty/Package.
	Gray	BTWM 2.5-2FT	20	BTWM 2.5-3FT	20	BTWM 3S	20
End plate 1.5 mm width 	Color	Reference Code	Qty/Pack.	Reference Code	Qty/Pack.	Reference Code	Qty/Package.
	Gray	TF-BTWM 2.5-2FT	10	TF-BTWM 2.5-3FT	10	TF-BTWM 3S	10
Connecting bridge 	N°. of poles	Reference Code	Qty/Pack.	Reference Code	Qty/Pack.	Reference Code	Qty/Package.
	2	PC-BTWM 2.5/2	25	-	-	PC-BTWM 2.5/2	25
	3	PC-BTWM 2.5/3	20	-	-	PC-BTWM 2.5/3	20
	4	PC-BTWM 2.5/4	15	-	-	PC-BTWM 2.5/4	15
	10	PC-BTWM 2.5/10	5	-	-	PC-BTWM 2.5/10	5
End bracket 8 mm width 	Color	Reference Code	Qty/Pack.	Reference Code	Qty/Pack.	Reference Code	Qty/Package.
	Gray	PF3-BTW	100	PF3-BTW	100	PF3-BTW	100
	Gray	PF4-BTW	100	PF4-BTW	100	PF4-BTW	100
Din rail / Support DIN EN 50022 	Type	Reference Code	Qty/Pack.	Reference Code	Qty/Pack.	Reference Code	Qty/Package.
	Flat	MR 35x7.5	2 m busbars	MR 35x7.5	2 m busbars	MR 35x7.5	2 m busbars
	Support	ST-BTW	25	ST-BTW	25	ST-BTW	25
Group identifier 	Color	Reference Code	Qty/Pack.	Reference Code	Qty/Pack.	Reference Code	Qty/Package.
	Gray	IG-BTW	50	IG-BTW	50	IG-BTW	50
	Clear	IG22-BTW ⁽¹⁾	25	IG22-BTW ⁽¹⁾	25	IG22-BTW ⁽¹⁾	25
Identifier ⁽²⁾ 		Reference Code	Qty/Pack.	Reference Code	Qty/Pack.	Reference Code	Qty/Package.
		IDB5-BTW	50	IDB5-BTW	50	IDB5-BTW	50

Note: (1) For assembly on PF4-BTW end bracket.

(2) Further details about identifiers on page 155.

Selection guide

BTWM Series - Disconnect terminal - Terminal blocks for fuses









		BTWM 2.5A 5 mm width 		BTWM S 8 mm width 		BTWM I 8 mm width 	
Technical data		Voltage / Current / Cross section		Voltage / Current / Cross section		Voltage / Current / Cross section	
IEC 60947-7-1		750 V~ / 16 A / 2.5 mm ²		500 V~ / 10 A / 4 mm ²		500 V~ / 10 A / 4 mm ²	
UL / CSA		600 V~ / 10 A / AWG 22 ... 12		600 V~ / 10 A / AWG 22 ... 10		600 V~ / 10 A / AWG 22 ... 10	
Fuse dimensions		-		5x20 or 5x25 mm		6.35x31.75 mm (1/4"x1 1/4")	
Cable stripping		10 mm		12 mm		12 mm	
Connection capacity		Connection capacity		Connection capacity		Connection capacity	
Rigid wire		0.5 ... 4 mm ²		0.5 ... 6 mm ²		0.5 ... 6 mm ²	
Flexible cable		0.5 ... 2.5 mm ²		0.5 ... 4 mm ²		0.5 ... 4 mm ²	
AWG Conductor		22 ... 12		22 ... 10		22 ... 10	
Reference Code	Color	Reference Code	Qty/Pack.	Reference Code	Qty/Pack.	Reference Code	Qty/Pack.
	Gray	BTWM 2.5A	50	BTWM S	20	BTWM I	20
				Note! Reserve fuse housed in disconnect lever.		Note! Reserve fuse housed in disconnect lever.	
End plate	Color	Reference Code	Qty/Pack.	Reference Code	Qty/Pack.	Reference Code	Qty/Pack.
1.5 mm width 	Gray	TF-BTWM 2.5A	10	TF-BTWM S-I	10	TF-BTWM S-I	10
Connecting bridge	Nº. of Poles	Reference Code	Qty/Pack.	Reference Code	Qty/Pack.	Reference Code	Qty/Pack.
	2	PC-BTWM 2.5/2	25	PC-BTWM 6/2	25	PC-BTWM 6/2	25
	3	PC-BTWM 2.5/3	20	PC-BTWM 6/3	20	PC-BTWM 6/3	20
	4	PC-BTWM 2.5/4	15	PC-BTWM 6/4	15	PC-BTWM 6/4	15
	10	PC-BTWM 2.5/10	5	PC-BTWM 6/10	5	PC-BTWM 6/10	5
End bracket	Color	Reference Code	Qty/Pack.	Reference Code	Qty/Pack.	Reference Code	Qty/Pack.
8 mm width 	Gray	PF3-BTW	100	PF3-BTW	100	PF3-BTW	100
	Gray	PF4-BTW	100	PF4-BTW	100	PF4-BTW	100
Din rail / Suppoty	Type	Reference Code	Qty/Pack.	Reference Code	Qty/Pack.	Reference Code	Qty/Pack.
DIN EN 50022 	Flat	MR 35x7.5	2 m bus bars	MR 35x7.5	2 m bus bars	MR 35x7.5	2 m bus bars
	Support	ST-BTW	25	ST-BTW	25	ST-BTW	25
Group identifier	Color	Reference Code	Qty/Pack.	Reference Code	Qty/Pack.	Reference Code	Qty/Pack.
	Gray	IG-BTW	50	IG-BTW	50	IG-BTW	50
	Clear	IG22-BTW ⁽¹⁾	25	IG22-BTW ⁽¹⁾	25	IG22-BTW ⁽¹⁾	25
Identifier ⁽²⁾		Reference Code	Qty/Pack.	Reference Code	Qty/Pack.	Reference Code	Qty/Pack.
		IDG10/5-BTW	44	IDB5-BTW	50	IDB5-BTW	50
		IDB5-BTW	50				
		IDG6/5-BTW	40				

Note: (1) For assembly on PF4-BTW end bracket.

(2) Further details about identifiers on page 155.

Selection Guide

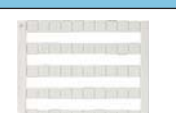

BTWM Series - 1IN-2OUT Terminal block - 2IN-2OUT Terminal block - Double ground terminal block

		BTWM 2.5E 5 mm width 		BTWM 2.5C 5 mm width 		BTWM 2.5CT 5 mm width 	
Technical data		Voltage / Current / Cross section		Voltage / Current / Cross section		Cross section	
IEC 60947-7-1		750 V~ / 24 A / 2.5 mm ²		750 V~ / 24 A / 2.5 mm ²		2.5 mm ²	
UL / CSA		600 V~ / 20 A / AWG 22 ... 12		600 V~ / 20 A / AWG 22 ... 12		AWG 22 ... 12	
Cable stripping		13 mm		13 mm		13 mm	
Connection capacity		Connection capacity		Connection capacity		Connection capacity	
Rigid wire		0.5 ... 4 mm ²		0.5 ... 4 mm ²		0.5 ... 4 mm ²	
Flexible cable		0.5 ... 2.5 mm ²		0.5 ... 2.5 mm ²		0.5 ... 2.5 mm ²	
AWG Conductor		22 ... 12		22 ... 12		22 ... 12	
Reference Code	Color	Reference Code	Qty/Pack.	Reference Code	Qty/Pack.	Reference Code	Qty/Pack.
	Gray	BTWM 2.5E	50	BTWM 2.5C	50		
	Green					BTWM 2.5CT	50
End plate 1.2 mm width 	Color	Reference Code	Qty/Pack.	Reference Code	Qty/Pack.	Reference Code	Qty/Pack.
	Gray	TF-BTWM 2.5E	10	TF-BTWM 2.5C	10	-	
	Green	-		-		TF-BTWM 2.5CT	10
Connecting bridge 	Nº. of Poles	Reference Code	Qty/Pack.	Reference Code	Qty/Pack.		
	2	PC-BTWM 2.5/2	25	PC-BTWM 2.5/2	25	-	
	3	PC-BTWM 2.5/3	20	PC-BTWM 2.5/3	20	-	
	4	PC-BTWM 2.5/4	15	PC-BTWM 2.5/4	15	-	
	10	PC-BTWM 2.5/10	5	PC-BTWM 2.5/10	5	-	
End bracket 8 mm width 	Color	Reference Code	Qty/Pack.	Reference Code	Qty/Pack.	Reference Code	Qty/Pack.
	Gray	PF3-BTW	100	PF3-BTW	100	PF3-BTW	100
	Gray	PF4-BTW	100	PF4-BTW	100	PF4-BTW	100
Rail / Support DIN EN 50022 	Type	Reference Code	Qty/Pack.	Reference Code	Qty/Pack.	Reference Code	Qty/Pack.
	Flat	MR 35x7.5	2 m busbars	MR 35x7.5	2 m busbars	MR 35x7.5	2 m busbars
	Support	ST-BTW	25	ST-BTW	25	ST-BTW	25
Group identifier 	Color	Reference Code	Qty/Pack.	Reference Code	Qty/Pack.	Reference Code	Qty/Pack.
	Gray	IG-BTW	50	IG-BTW	50	IG-BTW	50
	Clear	IG22-BTW ⁽¹⁾	25	IG22-BTW ⁽¹⁾	25	IG22-BTW ⁽¹⁾	25
Identifier ⁽²⁾ 		Reference Code	Qty/Pack.	Reference Code	Qty/Pack.	Reference Code	Qty/Pack.
		IDG10/5-BTW	44	IDG10/5-BTW	44	IDG10/5-BTW	44
		IDB5-BTW	50	IDB5-BTW	50	IDB5-BTW	50
		IDG6/5-BTW	40	IDG6/5-BTW	40	IDG6/5-BTW	40

Note: (1) For assembly on PF4-BTW end bracket.

(2) Further details about identifiers on page 155.

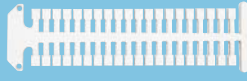
Selection Guide





Identifiers	IDB5 	IDG6/5 	IDG10/5 	IDG10/6 
Technical data	Technical data	Technical data	Technical data	Technical data
Identifier dimensions (height x width)	5 x 5 mm	6 x 5 mm	10 x 5 mm	10 x 6 mm
Identifier color	White	White	White	White
Marking color	Black	Black	Black	Black
Number of identifiers per packaging	50	40	44	36
Marking	Reference Code	Reference Code	Reference Code	Reference Code
Without marking	IDB5-BTW	IDB6/5-BTW	IDB10/5-BTW	IDB10/6-BTW
0	IDB5-BTW (0)	IDB6/5-BTW (0)	IDB10/5-BTW (0)	IDB10/6-BTW (0)
1	IDB5-BTW (1)	IDB6/5-BTW (1)	IDB10/5-BTW (1)	IDB10/6-BTW (1)
2	IDB5-BTW (2)	IDB6/5-BTW (2)	IDB10/5-BTW (2)	IDB10/6-BTW (2)
3	IDB5-BTW (3)	IDB6/5-BTW (3)	IDB10/5-BTW (3)	IDB10/6-BTW (3)
4	IDB5-BTW (4)	IDB6/5-BTW (4)	IDB10/5-BTW (4)	IDB10/6-BTW (4)
5	IDB5-BTW (5)	IDB6/5-BTW (5)	IDB10/5-BTW (5)	IDB10/6-BTW (5)
6	IDB5-BTW (6)	IDB6/5-BTW (6)	IDB10/5-BTW (6)	IDB10/6-BTW (6)
7	IDB5-BTW (7)	IDB6/5-BTW (7)	IDB10/5-BTW (7)	IDB10/6-BTW (7)
8	IDB5-BTW (8)	IDB6/5-BTW (8)	IDB10/5-BTW (8)	IDB10/6-BTW (8)
9	IDB5-BTW (9)	IDB6/5-BTW (9)	IDB10/5-BTW (9)	IDB10/6-BTW (9)
10	IDB5-BTW (10)	IDB6/5-BTW (10)	IDB10/5-BTW (10)	IDB10/6-BTW (10)
1, 2, 3 ... 8, 9, 10	IDB5-BTW (1-10)	IDB6/5-BTW (1-10)		
11, 12, 13 ... 18, 19, 20	IDB5-BTW (11-20)	IDB6/5-BTW (11-20)		
21, 22, 23 ... 28, 29, 30	IDB5-BTW (21-30)	IDB6/5-BTW (21-30)		
31, 32, 33 ... 38, 39, 40	IDB5-BTW (31-40)	IDB6/5-BTW (31-40)		
41, 42, 43 ... 48, 49, 50	IDB5-BTW (41-50)	IDB6/5-BTW (41-50)		
1, 2, 3 ... 20, 21, 22	-	-	IDB10/5-BTW (1-22)	-
23, 24, 25 ... 42, 43, 44	-	-	IDB10/5-BTW (23-44)	-
1, 2, 3 ... 16, 17, 18	-	-	-	IDB10/6-BTW (1-18)
19, 20, 21 ... 34, 35, 36	-	-	-	IDB10/6-BTW (19-36)
1, 2, 3 ... 48, 49, 50	IDB5-BTW (1-50)	-	-	-
51, 52, 53 ... 98, 99, 100	IDB5-BTW (51-100)	-	-	-
1, 2, 3 ... 38, 39, 40		IDB6/5-BTW (1-40)	-	-
41, 42, 43 ... 78, 79, 80		IDB6/5-BTW (41-80)	-	-
81, 82, 83 ... 118, 119, 120		IDB6/5-BTW (81-120)	-	-
1, 2, 3 ... 42, 43, 44			IDB10/5-BTW (1-44)	-
45, 46, 47 ... 86, 87, 88			IDB10/5-BTW (45-88)	-
89, 90, 91 ... 130, 131, 132			IDB10/5-BTW (89-132)	-
1, 2, 3 ... 34, 35, 36				IDB10/6-BTW (1-36)
37, 38, 39 ... 70, 71, 72				IDB10/6-BTW (37-72)
73, 74, 75 ... 106, 107, 108				IDB10/6-BTW (73-108)

Notes:

The identifiers are supplied in specific packaging and quantity for each type. Check the quantities on the chart above.

Custom markings on request.

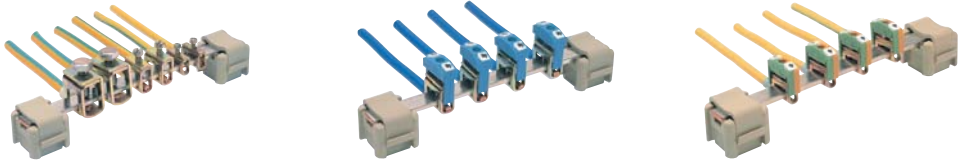
Selection Guide

CB Series Busbar connectors		CB4		CB10		CB35	
							
Technical data		Technical data		Technical data		Technical data	
Cross section		4 mm ²		10 mm ²		35 mm ²	
Screw		M3		M4		M6	
Busbar dimensions		10 x 3 mm		10 x 3 mm		10 x 3 mm	
Cable stripping		16 mm		19 mm		19 mm	
Tightening torque		0.5 Nm / 4.42 lb - in		1.2 Nm / 10.62 lb - in		2.8 Nm / 24.78 lb - in	
Connection capacity		Connection capacity		Connection capacity		Connection capacity	
Rigid wire		0.5 ... 6 mm ²		1.5 ... 10 mm ²		16 ... 50 mm ²	
Flexible cable		0.5 ... 4 mm ²		2.5 ... 10 mm ²		16 ... 35 mm ²	
Reference Code	Color	Reference Code	Qty/Pack	Reference Code	Qty/Pack	Reference Code	Qty/Pack
	-	CB4-BTW	200	CB10-BTW	100	CB35-BTW	50
	Blue	CB4N-BTW	100	CB10N-BTW	100	CB35N-BTW	50
	Vd/Am	CB4PE-BTW	100	CB10PE-BTW	100	CB35PE-BTW	50
Busbar support	Color	Reference Code	Qty/Pack	Reference Code	Qty/Pack	Reference Code	Qty/Pack
	Beige	SB-BTW ⁽¹⁾	50	SB-BTW ⁽¹⁾	50	SB-BTW ⁽¹⁾	50
Copper busbar 10 x 3 mm	Reference Code	Qty/Pack	Reference Code	Qty/Pack	Reference Code	Qty/Pack	Qty/Pack
Tin plated	BR10x3	1 m width	BR10x3	1 m width	BR10x3	1 m width	1 m width
							
Note ⁽²⁾							
Identifier ⁽²⁾	Reference Code	Qty/Pack	Reference Code	Qty/Pack	Reference Code	Qty/Pack	Qty/Pack
	IDB5-BTW	50	IDB5-BTW	50	IDB5-BTW	50	50

Note: (1) Further details on the identifiers on page 157.
 (2) Also fits busbars of: 15x2 mm, 15x3 mm, 12x2 mm e 6x6 mm.
 (3) Pictures for illustration purposes only.

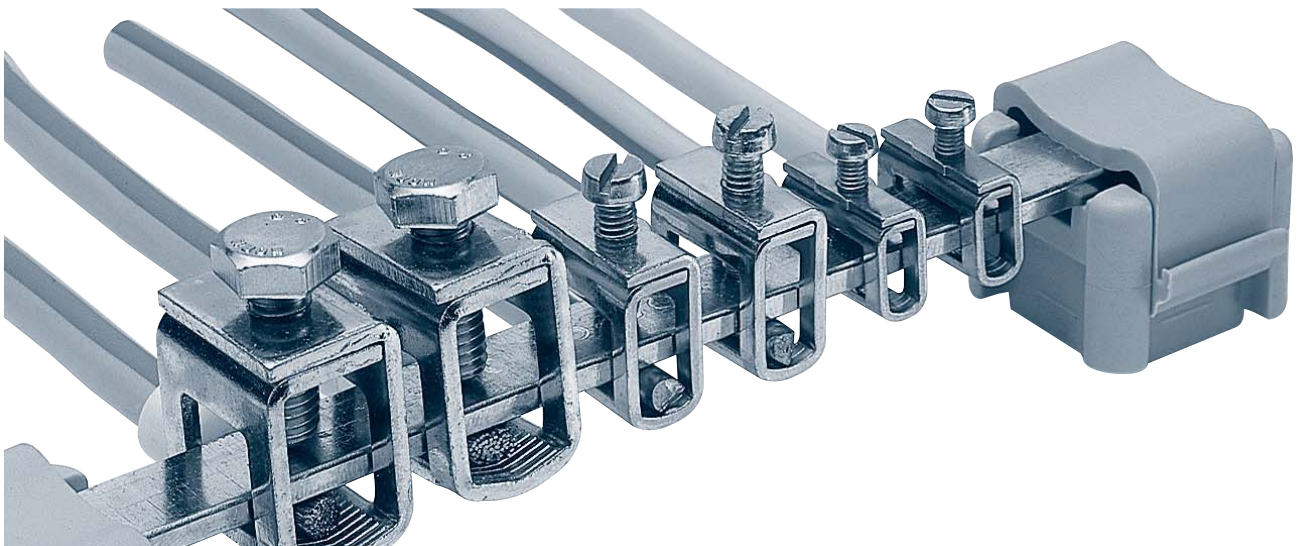

Overview

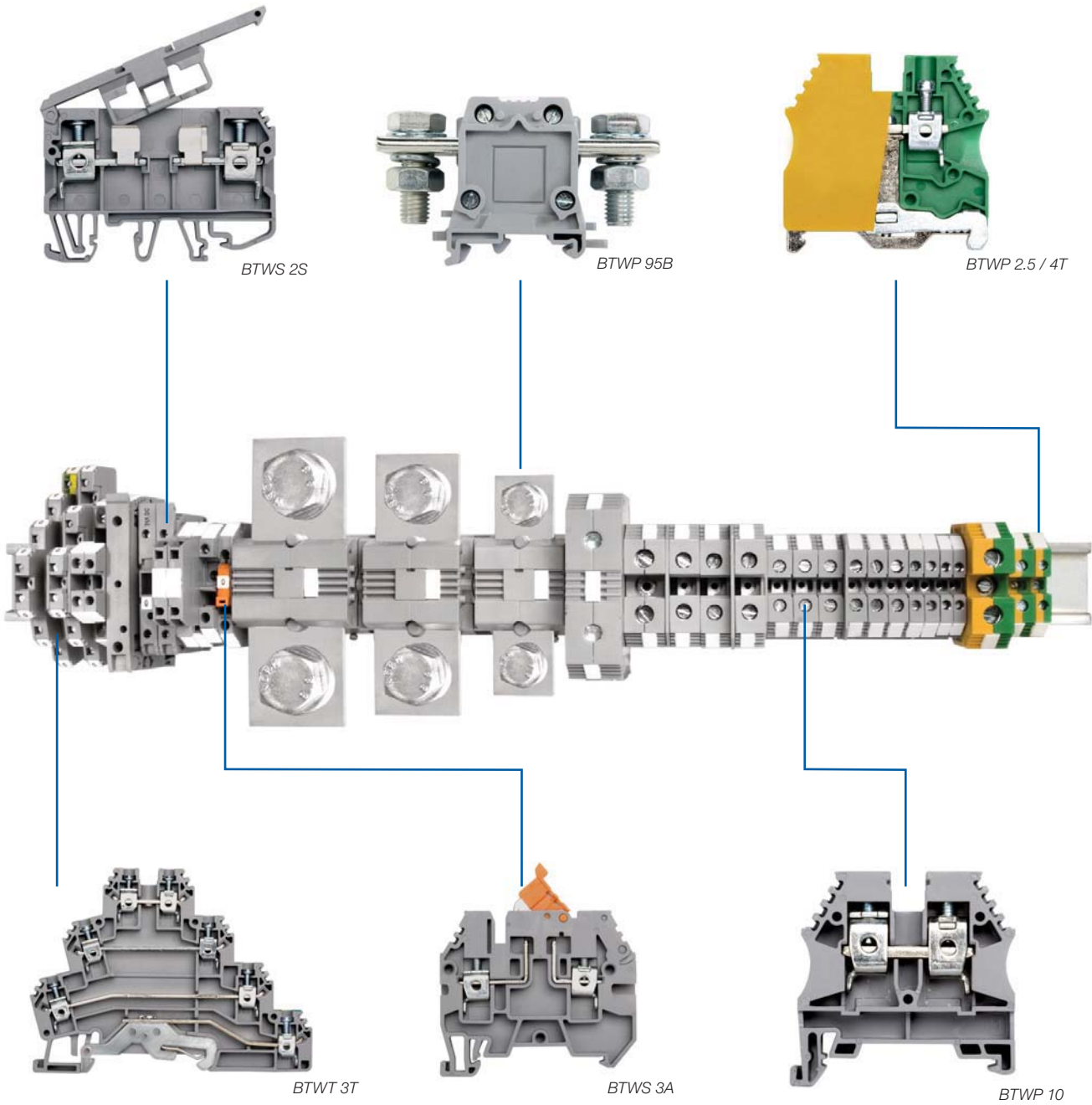

WEG Worldwide Operations

ARGENTINA

WEG EQUIPAMIENTOS
ELECTRICOS S.A.
(Headquarters San
Francisco-Cordoba)
Sgo. Pampiglione 4849
Parque Industrial San Francisco
2400 - San Francisco
Phone(s): +54 (3564) 421484
Fax: +54 (3564) 421459
info-ar@weg.net
www.weg.net/ar

AUSTRALIA

WEG AUSTRALIA PTY. LTD.
3 Dalmore Drive
Carribean Park Industrial Estate
Scoresby VIC 3179 - Melbourne
Phone(s): 61 (3) 9765 4600
Fax: 61 (3) 9753 2088
info-au@weg.net
www.weg.net/au

BELGIUM

WEG BENELUX S.A.
Rue de l'Industrie 30 D,
1400 Nivelles
Phone(s): + 32 (67) 88-8420
Fax: + 32 (67) 84-1748
info-be@weg.net
www.weg.net/be

CHILE

WEG CHILE S.A.
Los Canteros 8600
La Reina - Santiago
Phone(s): (56-2) 784 8900
Fax: (56-2) 784 8950
info-cl@weg.net
www.weg.net/cl

CHINA

WEG (NANTONG) ELECTRIC
MOTOR MANUFACTURING Co., Ltd.
No. 128 - Xinkai Nan Road,
Nantong Economic and
Technological Development Area
Jiangsu Province, China PC226010
Phone(s): 86 513 8598 9329
Fax: 86 513 8592 1310
info-cn@weg.net
www.weg.net/cn

COLOMBIA

WEG COLOMBIA LTDA
Calle 46A N82 - 54
Portería II - Bodega 7 - San
Cayetano II - Bogotá
Phone(s): (57 1) 416 0166
Fax: (57 1) 416 2077
info-co@weg.net
www.weg.net/co

FRANCE

WEG FRANCE SAS
ZI de Chenes - Le Loup
13 Rue du Morellon - BP 738
38297 Saint Quentin Fallavier
Phone(s): +33 (0) 4 74 99 11 35
Fax: +33 (0) 4 74 99 11 44
info-fr@weg.net
www.weg.net/fr

GERMANY

WEG GERMANY GmbH
Alfred-Nobel-Str. 7-9
D-50226 Frechen
Phone(s): +49 (2234) 9 5353-0
Fax: +49 (2234) 9 5353-10
info-de@weg.net
www.weg.net/de

INDIA

WEG Electric (India) Pvt. Ltd.
#38, Ground Floor, 1st Main
Road, Lower Palace Orchards,
Bangalore - 560 003
Phone(s): +91-80-4128 2007
+91-80-4128 2006
Fax: +91-80-2336 7624
info-in@weg.net
www.weg.net/in

ITALY

WEG ITALIA S.R.L.
V.le Brianza 20 - 20092 - Cinisello
Balsamo - Milano
Phone(s): (39) 02 6129-3535
Fax: (39) 02 6601-3738
info-it@weg.net
www.weg.net/it

JAPAN

WEG ELECTRIC MOTORS
JAPAN CO., LTD.
Matsumoto Bldg. 2F, 3-23-7
Kamata, Ohta-ku,
Tokyo, Japan 144-0052
Phone(s): (81) 3 3736-2998
Fax: (81) 3 3736-2995
info-jp@weg.net
www.weg.net/jp

MEXICO

WEG MEXICO, S.A. DE C.V.
Carretera Jorobas-Tula Km. 3.5,
Manzana 5, Lote 1
Fraccionamiento Parque
Industrial - Huehuetoca,
Estado de México - C.P. 54680
Phone(s): + 52 (55) 5321 4275
Fax: + 52 (55) 5321 4262
info-mx@weg.net
www.weg.net/mx

NETHERLANDS

WEG NETHERLANDS
Sales Office of
WEG Benelux S.A.
Keulenstraat 4E
7418 ET Deventer
Phone(s): +31 (0) 570-620550
Fax: +31 (0) 570-620560
info-nl@weg.net
www.weg.net/nl

PORTUGAL

WEG EURO - INDÚSTRIA
ELÉTRICA, S.A.
Rua Eng. Frederico Ulrich
Apartado 6074
4476-908 - Maia
Phone(s): +351 229 477 705
Fax: +351 229 477 792
info-pt@weg.net
www.weg.net/pt

RUSSIA

WEG RUSSIA
Pochainskaya Str. 17
Nizhny Novgorod
603001 - Russia
Phone(s): +7-831-2780425
Fax: +7-831-2780424
info-ru@weg.net
www.weg.net/ru

SPAIN

WEG IBERIA S.L.
Avenida de la Industria,25
28823 Coslada - Madrid
Phone(s) : (34) 916 553 008
Fax : (34) 916 553 058
info-es@weg.net
www.weg.net/es

SINGAPORE

WEG SINGAPORE PTE LTD
159, Kampong Ampat,
#06-02A KA PLACE.
Singapore 368328.
Phone(s): +65 6858 9081
Fax: +65 6858 1081
info-sg@weg.net
www.weg.net/sg

SWEDEN

WEG SCANDINAVIA AB
Box 10196
Verkstadgatan 9
434 22 Kungsbacka
Phone(s): (46) 300 73400
Fax: (46) 300 70264
info-se@weg.net
www.weg.net/se

UK

WEG ELECTRIC
MOTORS (U.K.) LTD.
28/29 Walkers Road
Manorside Industrial Estate
North Moons Moat - Redditch
Worcestershire B98 9HE
Phone(s): 44 (0)1527 596-748
Fax: 44 (0)1527 591-133
info-uk@weg.net
www.weg.net/uk

UNITED ARAB EMIRATES

WEG MIDDLE EAST FZE
JAFZA - JEBEL ALI FREE ZONE
Tower 18, 19th Floor,
Office LB181905
Dubai - United Arab Emirates
info-ae@weg.net
www.weg.net/ae

USA

WEG ELECTRIC
CORP
1327 Northbrook Parkway,
Suite 490
Suwanee 30024
Phone(s): 1-770-338-5656
Fax: 1-770-338-1632
info-us@weg.net
www.weg.net/us

VENEZUELA

WEG INDUSTRIAS
VENEZUELA C.A.
Parcela T-4-A Transversal 9 Urb.
Industrial Carabobo Catastral
79-101 Edf. ELIMECA Loc. ELI-
MECA, Zona Postal 2003, Va-
lencia, Edo. Carabobo
Phone(s): (58) 241 838 9239
Fax: (58) 241 838 9239
info-ve@weg.net
www.weg.net/ve



WEG Equipamentos Eléctricos S.A.
International Division
Av. Prefeito Waldemar Grubba, 3000
89256-900 - Jaraguá do Sul - SC - Brazil
Phone: 55 (47) 3276-4002
Fax: 55 (47) 3276-4060
www.weg.net